

## Problem 1 – 20 points

a) Consider the composite body shown below. Find the x centroid of the body.

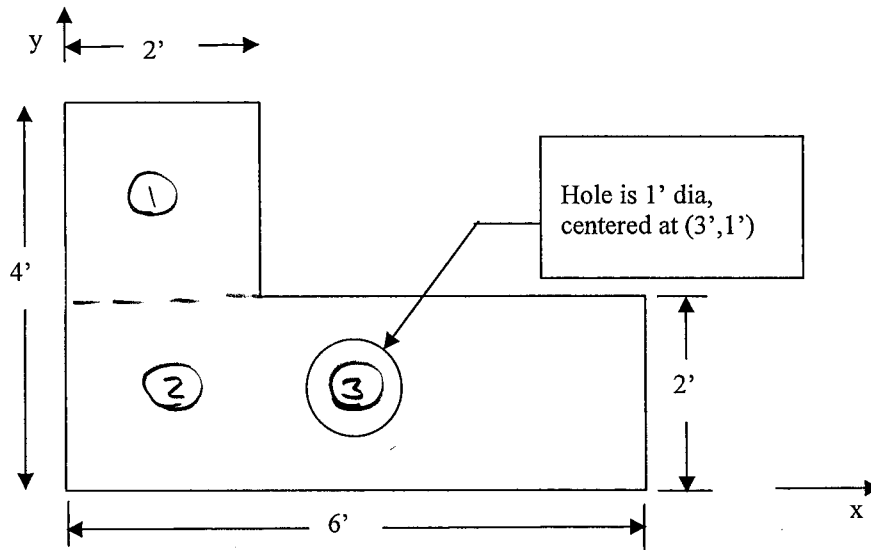

part	$A_i$ (ft <sup>2</sup> )	$\bar{x}_i$ (ft)	$A_i \bar{x}_i$ (ft <sup>3</sup> )
①	4	1	4
②	12	3	36
③	$-\frac{\pi}{4}$	3	$-3\pi/4$
	15.21		37.64

$$\bar{x} = \frac{\sum A_i \bar{x}_i}{\sum A_i} = \frac{37.64 \text{ ft}^3}{15.21 \text{ ft}^2} = 2.47 \text{ ft}$$

- b) Consider the beam with a distributed load shown on the left below. Find the effective force and where that force should act, i.e. find the value for  $F$  and  $\bar{x}$ .

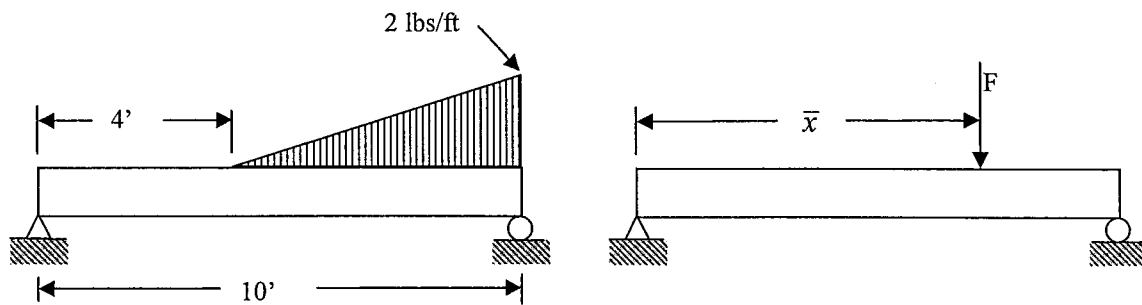

$$F = \frac{1}{2} (6' \times 2 \text{ lbs/ft}) = 6 \text{ lbs}$$

$$\bar{x} = 4' + \frac{2}{3} (6') = 8'$$

Problem 2 – 40 points

Calculate the member forces in: HJ, DF, and EC. Show all work, and place your answers in the boxes provided.

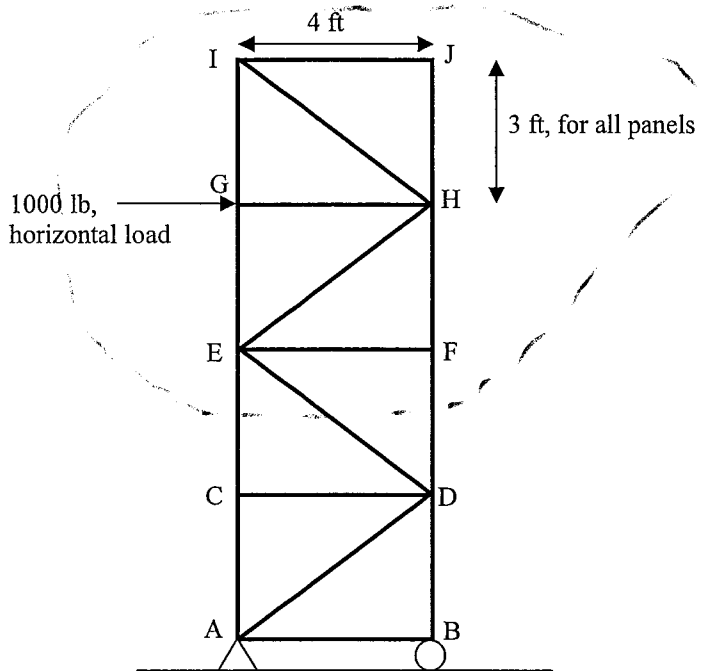

Member	Force (lb)	T or C
HJ	0	-
DF	750	C
EC	1500	T



$$\sum F_x = 0: T_{IJ} = 0$$

$$\sum F_y = 0: T_{JH} = 0$$

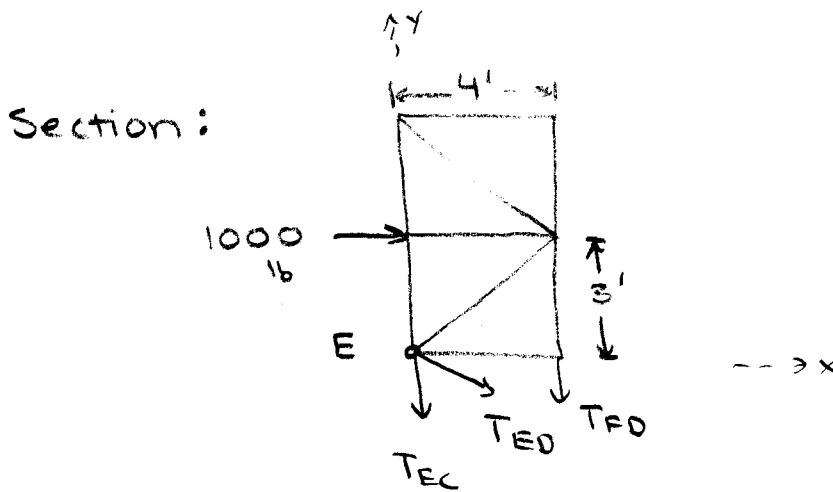

$$\sum F_x = 0: T_{ED} \frac{4}{3} + 1000 = 0 \quad T_{ED} = -1250 \text{ lb}$$

$$\sum \text{Moments about E} = 0: -T_{FD}(4') - (1000 \text{ lb})(3') = 0 \quad T_{FD} = -750 \text{ lb}$$

$$\sum F_y = 0: -T_{EC} - T_{FD} - \frac{3}{5} T_{ED} = 0 \quad T_{EC} = 1500 \text{ lb}$$

**Problem 3 – 40 points**

The device at right is used to automatically smash cans. The disc is pinned at A. Assume the walls of the cylinder to be frictionless. Determine the forces acting on the smashing block if the load P is known and the system is in static equilibrium.

Set up but DO NOT SOLVE this problem.  
Be sure to clearly identify your systems, equations, and unknowns.

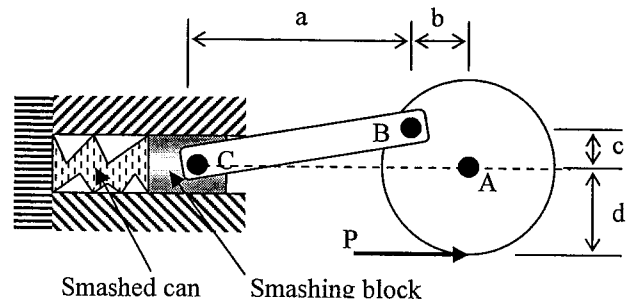

Smashing block:

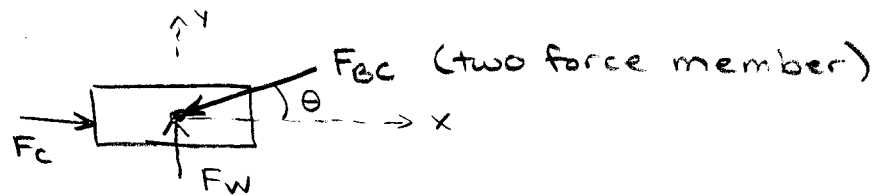

Unknowns:  $F_c, F_w, \theta, F_{bc}$

$$\sum F_x = 0: F_c = F_{bc} \cos \theta \quad (1)$$

$$\theta = \tan^{-1} \left( \frac{c}{a} \right) \quad (3)$$

$$\sum F_y = 0: F_w = F_{bc} \sin \theta \quad (2)$$

Disc:

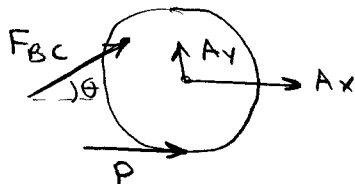

$$\sum \text{Moments about A} = 0: Pd - (F_{bc} \cos \theta) c - (F_{bc} \sin \theta) b = 0 \quad (4)$$