

DC motors

DC motors are important in many applications. In portable applications using battery power, DC motors are a natural choice. DC machines are also used in applications where high starting torque and accurate speed control over a wide range are important.

Major applications for DC motors are: elevators, steel mills, rolling mills, locomotives, and excavators.

Like other rotating machines, DC motors result from the interaction of two magnets. The interaction is best understood as one of like poles repelling (north poles repel north poles, south poles repel south poles).

One magnet is attached to the frame of the motor and is produced by the current in the field windings. The other magnet results from current in the armature windings.

Principle of operation

The field current produces the stationary magnet shown. The armature current I_a produces the rotating magnet. Rotation results from the fact that like poles repel.

In the diagram below, the rotation continues until N-S alignment, resulting in lock-up—that is, if nothing is done to prevent it.

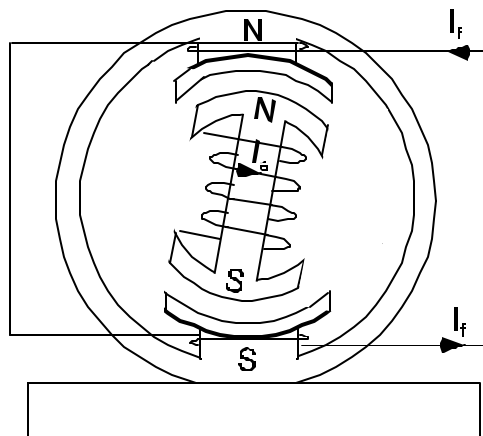

A commutator is a switch that prevents N-S alignment by reversing the direction of armature current at just the right time to keep the torque in the direction of intended rotation.

The direction of the field current does not change—changes to the direction of current is confined to the armature.

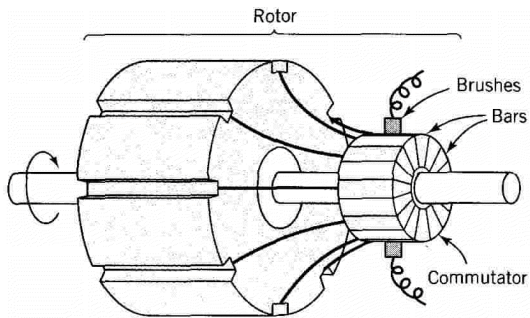

The commutator is a rotating switch. The fixed contacts are carbon brushes spring-loaded against the moving contacts on the shaft.

The back EMF on the armature is produced via Faraday's law.

$$V = -\frac{dj}{dt}$$

If the flux were sinusoidal (*which it's not—this is a DC machine!*), the corresponding phasor equation would be

$$\mathbf{V} = -j\omega\mathbf{f}$$

In DC motors, the back EMF, denoted E_a , is proportional to the flux, times the shaft speed. The constant of proportionality is K_a , the armature constant.

$$E_a = K_a j \omega_m$$

The torque developed by the armature is proportional to the product of the magnetic flux and the armature current. The constant of proportionality is the armature constant.

$$T_D = K_a j I_a$$

The developed power is the product of this torque and the shaft speed.

$$P_D = T_D \omega = K_a j I_a \omega = K_a j \omega I_a$$

$$P_D = E_a I_a$$

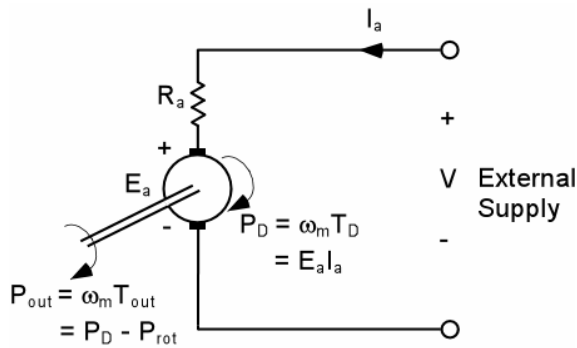

We consider two types of DC motors—the series motor ($I_f = I_a$) and the shunt motor (where the field current and the armature current are different).

Series DC motors

The equivalent circuit is:

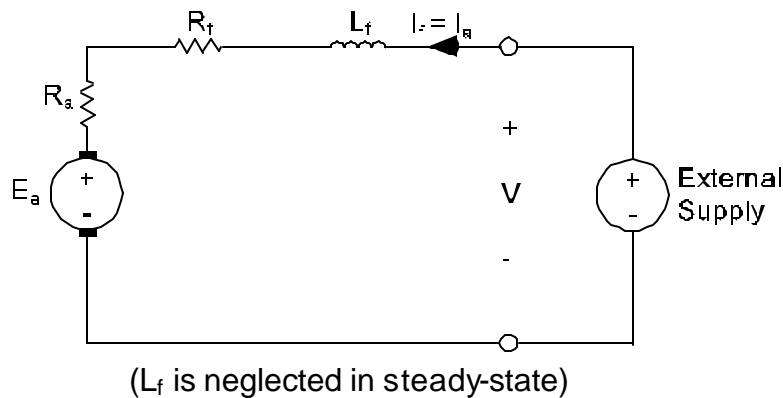

$$E_a = V - (R_a + R_f) I_a \quad (\text{steady-state})$$

$$E_a = K_a \mathbf{j} \omega_m$$

$$T_D = K_a \mathbf{j} I_a$$

linear when the magnetic core of the motor is not saturated

If we assume the machine is working in its linear region, $\mathbf{j} = K_f I_f$.

This results in the developed torque being proportional to the square of the armature current.

$$T_D = K_a \mathbf{j} I_a = K_a K_f I_f I_a = K_a K_f I_a I_a = K_a K_f I_a^2$$

Series motors develop very high starting torque because of the large starting current in motors.

This is a good thing—high starting torque is critical in many applications.

Care must be taken when using DC motors. This is because the shaft speed is inversely proportional to the armature current—just think what this implies for a motor accidentally disconnected from its load (so that I_a becomes very small)!

Let's look at this more closely.

$$E_a = V - (R_a + R_f)I_a = K_a j \omega_m$$

$$\omega_m = \frac{V}{K_a j} - \frac{(R_a + R_f)I_a}{K_a j}$$

Since, $I_a = I_f$ in a series machine, and since in the linear region, $j \propto I_f$ (no magnetic saturation),

$$\omega_m = \frac{K_1}{I_a} - K_2$$

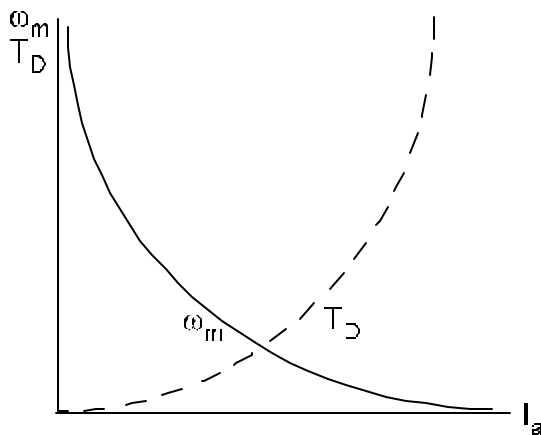

When a DC series motor is initially switched on, the large surge of current produces a high starting torque. Starting currents often have to be limited to prevent electrical and mechanical damage.

If the motor load is lost, T_D will get quite small, causing I_a to become small which, in turn, results in overspeeding the motor. Series motors must always be fitted with overspeed protection.

Shunt DC motors

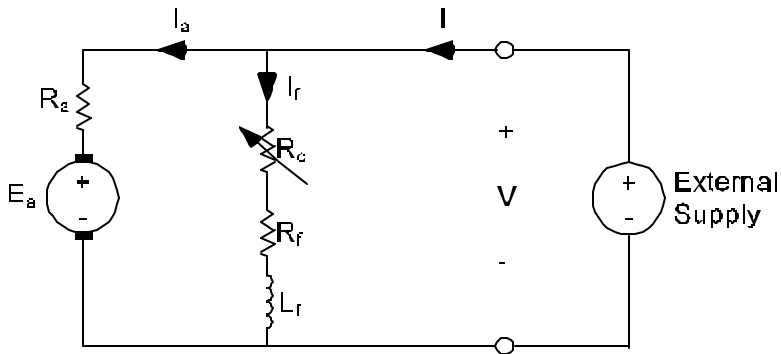

$$E_a = V - R_a I_a = K_a j \omega_m$$

$$T_D = K_a j I_a \quad I_f = \frac{V}{R_c + R_f}$$

R_c controls $I_f \propto j$. Solving for ω_m

$$\omega_m = \frac{V}{K_a j} - \frac{I_a R_a}{K_a j}$$

V , R_a , and K_a are constants. If R_c is not changed, j remains constant as well.

$$\omega_m = K_3 - K_4 I_a \quad T_D = K_a j I_a$$

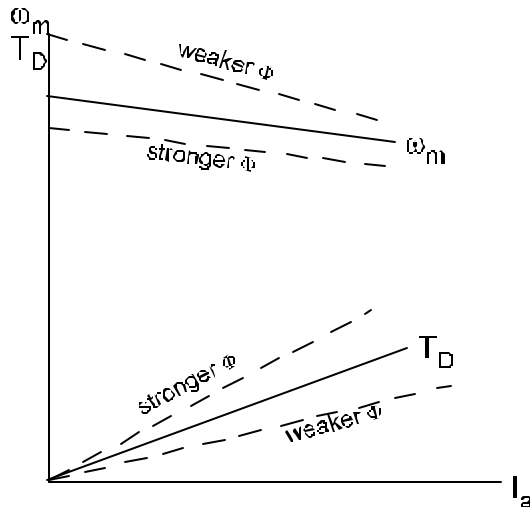

The starting torque is as high as in the series motor. However, the shunt, or separately-excited, motor has a safe no-load speed, providing that the field circuit is not de-energized. Loss-of-field protection is usually provided to guard against overspeeding.

The control resistor R_c enables speed to be controlled very accurately over a wide range.

Power flow in DC motors

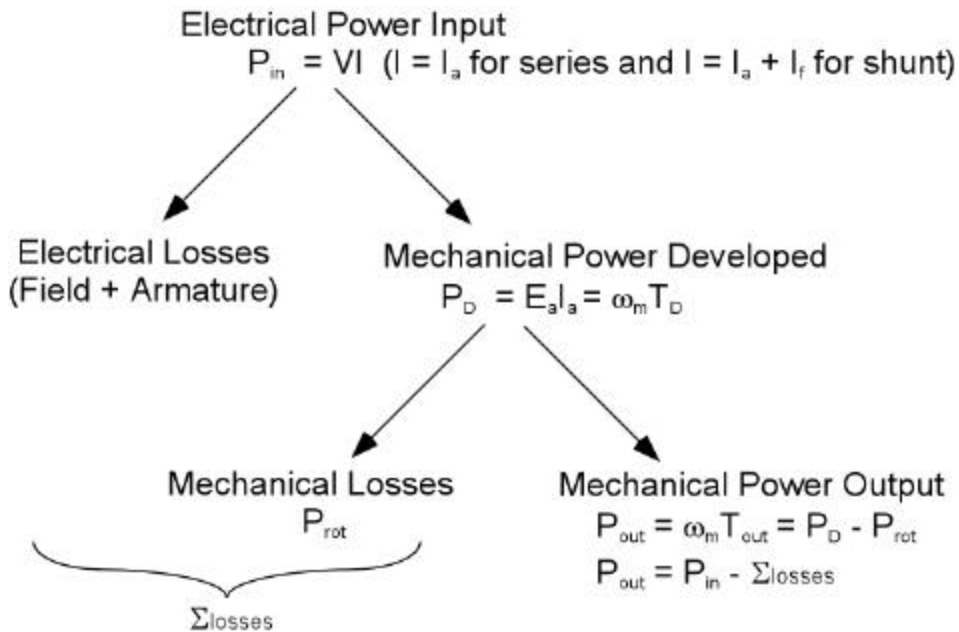

Example

A DC series motor is rated at 1200V, 750hp, 2500rpm. It has an armature resistance of 0.14Ω and field resistance of 0.06Ω . It draws a current of 520A from the supply when delivering rated load. Find:

- i) rated output torque.
- ii) rated developed torque.
- iii) rated efficiency.
- iv) rotational losses at rated speed.
- v) speed when the load is changed, causing the line current to drop to 260 A.
- vi) developed torque for the conditions in part (v).
- vii) horsepower output for the conditions in (v) if the rotational losses are proportional to speed².

Solution

Under rated conditions the motor is modeled as follows:

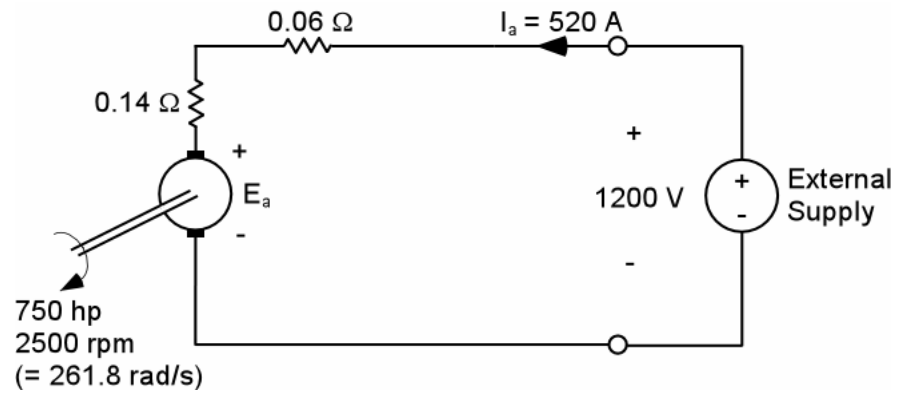

Example

A DC shunt motor is rated at 600V, 255hp, 2000rpm. It has an armature resistance of 0.07Ω and a total field resistance of 80Ω . It draws a current of 353A from the supply when delivering rated load.

Find:

- i) rated output torque
- ii) rated developed torque
- iii) rated efficiency
- iv) rotational losses at rated speed
- v) speed when the load is changed, causing the line current to rise to 500 A. (Field resistance is unaltered.)
- vi) developed torque for the conditions in part (v).
- vii) horsepower output for the conditions in (v) if the rotational losses are proportional to speed².

Solution

Under rated conditions the motor is modeled as follows:

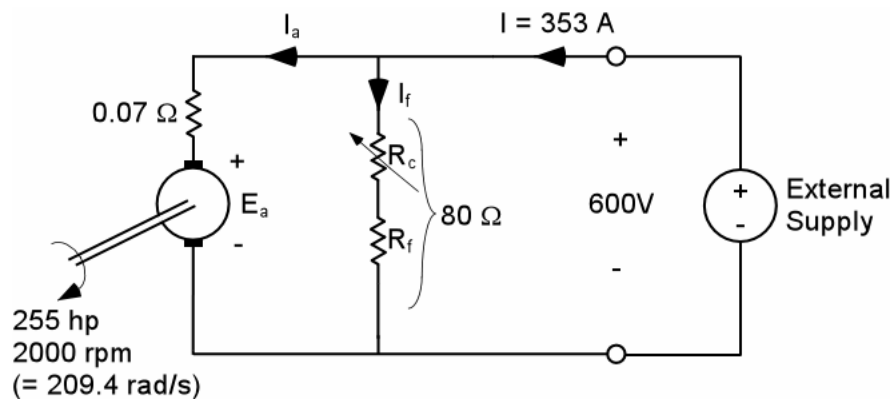

Example

A DC shunt motor is rated at 500V, 100hp, 3600rpm. It has an armature resistance of 0.1Ω and a total field resistance of 100Ω . It draws a current of 165A from the supply when delivering rated load. Find:

- i) rated output torque.
- ii) rated developed torque.
- iii) rated efficiency.
- iv) rotational losses at rated speed.
- v) line current when the total field resistance is changed such that ϕ is doubled. (Developed torque is unaltered.)
- vi) speed for the conditions in part (v).
- vii) horsepower output for the conditions in (v) if the rotational losses are proportional to speed².
- viii) efficiency for the conditions in (v).

Solution

Under rated conditions the motor is modeled as follows:

