

Thermocouples (adapted from Omega® Engineering)

In 1821, Thomas Seebeck discovered that a current flows when two dissimilar metals, joined at both ends, is heated at one end.

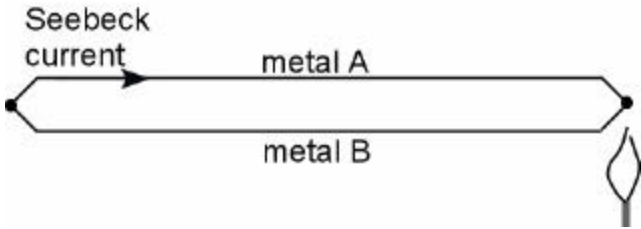

If the circuit is opened, a net voltage, the Seebeck voltage, is present. This voltage is a function of the two metals and the junction temperature.

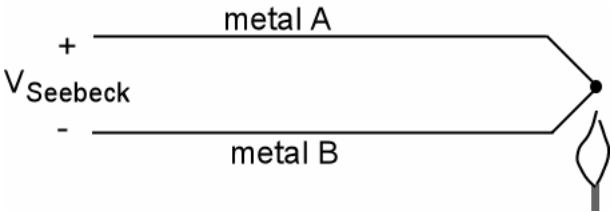

The voltage-temperature relationship is not linear for thermocouples, but the functional relationships are known and tabulated for common thermocouples.

Polynomial coefficients from the NATIONAL BUREAU OF STANDARDS

	TYPE E	TYPE J	TYPE K	TYPE R	TYPE S	TYPE T
	Ni-10% Cr (+) -vs- Constantan	Fe (+) -vs- Constantan	Ni-10% Cr (+) -vs- Ni-5% AISi	Pt-13% Rh (+) -vs- Pt	Pt-10% Rh (+) -vs- Pt	Cu (+) -vs- Constantan
	-100°C to 1000°C ±0.5°C, 9 th order	0°C to 760°C ±0.1°C, 5 th order	0°C to 1370°C ±0.7°C, 8 th order	0°C to 1000°C ±0.5°C, 8 th order	0°C to 1750°C ±1°C, 9 th order	-160°C to 400°C ±0.5°C, 7 th order
a ₀	0.104967248	-0.048868252	0.226584602	0.263632917	0.927763167	0.100860910
a ₁	17189.45282	19873.14503	24152.10900	179075.491	169526.5150	25727.94369
a ₂	-282639.0850	-218614.5353	67233.4248	-48840341.37	-31568363.94	-767345.8295
a ₃	12695339.5	11569199.78	2210340.682	1.90002 E+10	8990730663	78025595.81
a ₄	-448703084.6	-264917531.4	-860963914.9	-4.82704 E+12	-1.63565 E+12	-9247486589
a ₅	1.10866 E+10	2018441314	4.83506 E+10	7.62091 E+14	1.88027 E+14	6.97688 E+11
a ₆	-1.76807 E+11		-1.18452 E+12	-7.20026 E+16	-1.37241 E+16	-2.66192 E+13
a ₇	1.71842 E+12		1.38690 E+13	3.71496 E+18	6.17501 E+17	3.94078 E+14
a ₈	-9.19278 E+12		-6.33708 E+13	-8.03104 E+19	-1.56105 E+19	
a ₉	2.06132 E+13				1.69535 E+20	

thermocouple T-V relation $T = a_0 + a_1 V_{tc} + a_2 (V_{tc})^2 + \dots$
 [T] ~ °C V_{tc} ~ Volts
 (assumes reference junction at 0°C)



veterinary probe



Measuring the Seebeck voltage

When measuring the thermocouple voltage, one must be aware that the act of measuring can create additional thermoelectric junctions.

Consider measuring the voltage across a Cu-Constantan (type T) thermocouple

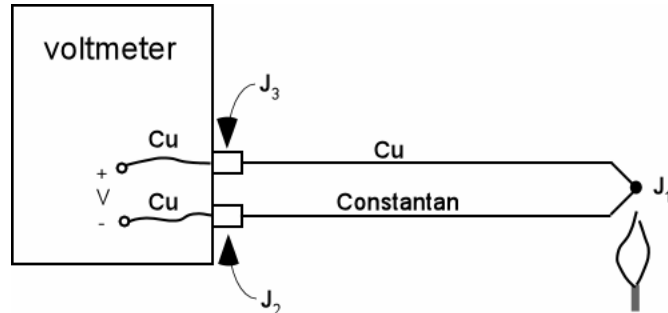

Consider the equivalent thermoelectric circuit that describes the system above.

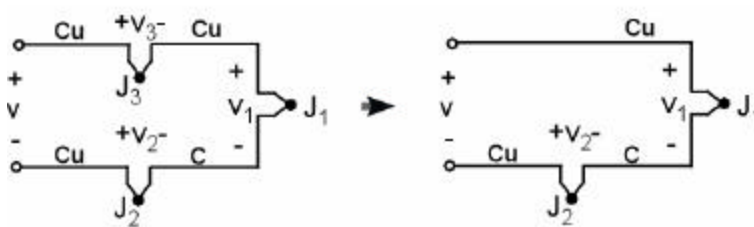

To know the temperature at J_1 , two things must be known:

1. The type of junction (in this case Cu-Constantan) and
2. The junction voltage, v_1 .

In this case, $v_3 = 0$ since the junction is Cu-Cu. But v_2 is Cu-C, and v_1 cannot be determined from v (the voltmeter reading) unless v_2 is known. v_2 can be fixed by placing J_2 in a known temperature.

We cannot determine the temperature at J_1 without knowing the temperature at J_2 . This can be accomplished using an ice bath. ($T_{j_2} = 0^\circ\text{C}$)

$$v = v_1 - v_2 \approx \alpha(t_{j_1} - t_{j_2}) = \alpha [(T_{j_1}(\text{C})+273.15) - (T_{j_2}(\text{C})+273.15)]$$

$$v = \alpha (T_{j_1}(\text{C}) - T_{j_2}(\text{C})) = \alpha (T_{j_1}(\text{C}) - 0) = \alpha T_{j_1}$$

$$v = \alpha T_{j_1}$$

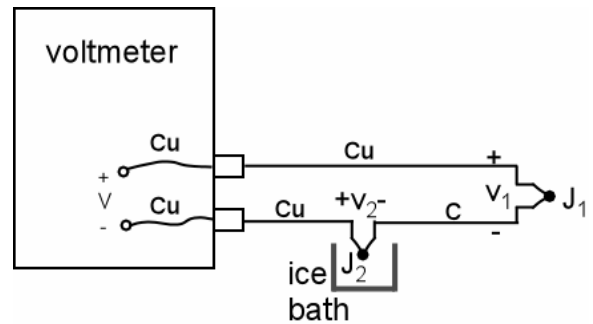

Now suppose a different type of thermocouple is used, suppose Type J, which is Fe-Constantan.

If J_3 and J_4 are at the same temperature, their junction voltages will cancel and $v = \alpha T_{j_1}$.

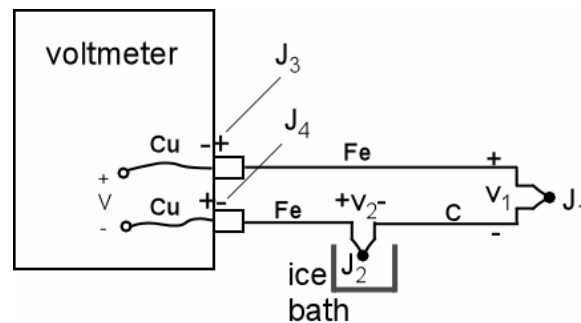

An isothermal block (high thermal conductivity and low electrical conductivity) can help to insure the junction temperatures remain equal.

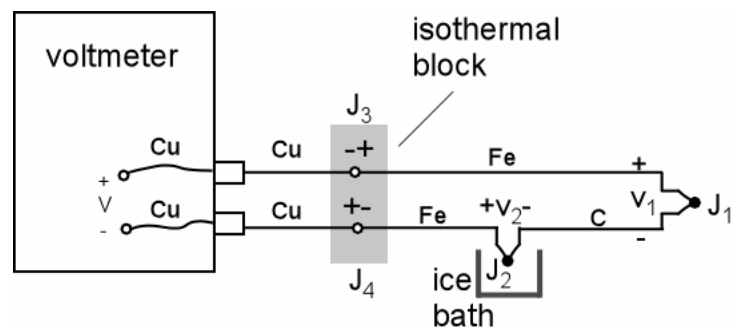

This circuit still requires two thermocouples, J_1 and J_2 . It is possible to eliminate the reference thermocouple.

Step 1: Eliminating the ice bath

Replace the ice bath with an isothermal block at temperature T_{ref} .

$$v = \alpha (T_{j1} - T_{ref})$$

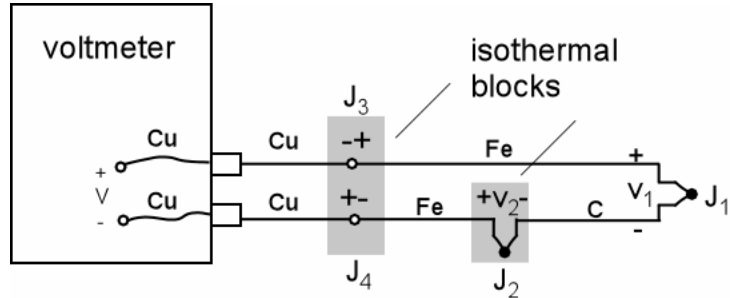

Step 2: Join the isothermal blocks

Temperature of isothermal block is T_{ref} .

$$v = \alpha (T_{j1} - T_{ref})$$

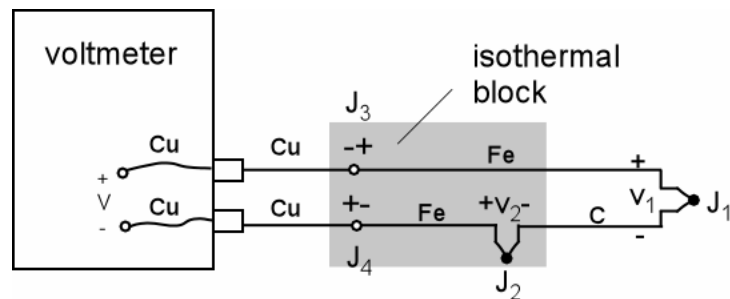
Step 3: Eliminate J_2

Use law of intermediate metals to eliminate J_2

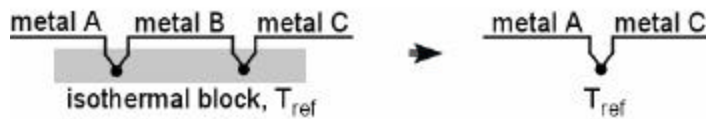

$$v = \alpha (T_{j1} - T_{ref})$$

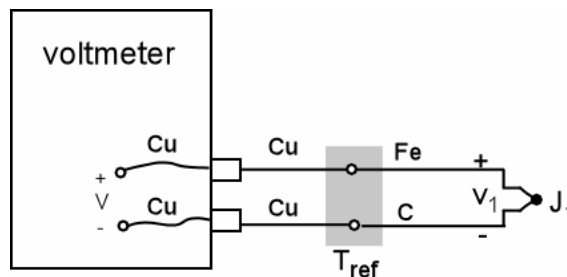

To measure T_{ref} , we can use an RTD or some other convenient temperature sensor.

So, why use thermocouples?

Why, when another temperature transducer must be used to measure T_{ref} , does one even bother with the thermocouple in the first place? Why not just use the other temperature transducer to measure the temperature of interest and be done with it?

There are two primary reasons: temperature range and ruggedness. RTDs can be used to measure temperatures that RTDs, thermistors, and IC sensors simply cannot. They are also very rugged; thermocouples can be welded to a metal part; or they can be clamped under a screw.

Their wide temperature range and ruggedness makes them the workhorses of temperature measurement in a wide variety of applications.

Several thermocouples can be switched so that all use the same isothermal block.

This allows one temperature sensor to service many thermocouples.

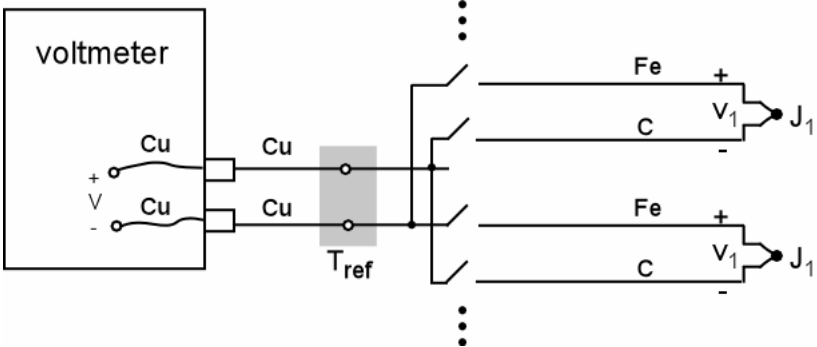

Type K (Chromel / Alumel)

Type K is the 'general purpose' thermocouple. It is low cost and is available in a wide variety of probes. Thermocouples are available in the -200°C to $+1200^{\circ}\text{C}$ range. Sensitivity is approx $41\mu\text{V}/^{\circ}\text{C}$. Although Type K is presently most popular with users, the improved performance of Type N will serve to supplant Type K as the most popular thermocouple.

Type E (Chromel / Constantan)

Type E has a high output which makes it well suited to low temperature (cryogenic) use.

Type J (Iron / Constantan)

Limited range (-40 to $+750^{\circ}\text{C}$) makes type J less popular than type K. The main application is with old equipment that can not accept 'modern' thermocouples. J types should not be used above 760°C as an abrupt magnetic transformation will cause permanent decalibration.

Type N (Nicrosil / Nisil)

High stability and resistance to high temperature oxidation makes type N suitable for high temperature measurements without the cost of platinum (B,R,S) types. Designed to be an 'improved' type K, it is becoming more popular.

Thermocouple types B, R and S are all 'noble' metal thermocouples and exhibit similar characteristics. They are the most stable of all thermocouples, but due to their low sensitivity (approx $10\mu\text{V}/^{\circ}\text{C}$) they are usually only used for high temperature measurement ($>300^{\circ}\text{C}$).

Type B (Platinum / Rhodium)

Suited for high temperature measurements up to 1800°C . Type B thermocouples give the same output at 0°C and 42°C . This makes them useless below 50°C .

Type R (Platinum / Rhodium)

Suited for high temperature measurements up to 1600°C . Low sensitivity ($10\mu\text{V}/^{\circ}\text{C}$) and high cost makes them unsuitable for general purpose use.

Type S (Platinum / Rhodium)

Suited for high temperature measurements up to 1600°C . Low sensitivity ($10\mu\text{V}/^{\circ}\text{C}$) and high cost makes them unsuitable for general purpose use. Due to its high stability type S is used as the standard of calibration for the melting point of gold (1064.43°C).

Source: picotech

When selecting thermocouple types, ensure that your measuring equipment does not limit the range of temperatures that can be measured. Note that thermocouples with low sensitivity (B, R and S) have a correspondingly lower resolution.

type	Range (°C)	0.1°C resolution	0.025°C resolution
B	100 to 1800	1030 to 1800	-
E	-270 to 790	-240 to 790	-140 to 790
J	-210 to 1050	-210 to 1050	-120 to 1050
K	-270 to 1370	-220 to 1370	-20 to 1150
N	-260 to 1300	-210 to 1300	340 to 1260
R	-50 to 1760	330 to 1760	-
S	-50 to 1760	250 to 1760	-

Precautions and Considerations for Using Thermocouples

Most measurement problems and errors with thermocouples are due to a lack of understanding of how thermocouples work.

Connection problems: Many measurement errors are caused by unintentional junctions. Remember that any junction of two different metals will cause a junction. If you need to increase the length of the leads from your thermocouple, you must use the correct type of thermocouple extension wire (for example, type K for type K thermocouples). Using any other type of wire will introduce a junction. Any connectors used must be made of the correct thermocouple material and correct polarity must be observed.

Lead resistance: To minimize thermal loading and improve response times, thermocouples are often made of thin wire (For Pt TCs, cost is also a consideration). This can cause the thermocouple to have a high resistance which can make it sensitive to noise and can also cause errors due to the input impedance of the measuring instrument. A typical exposed junction thermocouple with 32AWG wire (0.25mm diameter) will have a resistance of about 15 Ω /m. It is always a good precaution to measure the resistance of your thermocouple before use.

Decalibration is the process of unintentionally altering the makeup of thermocouple wire. The usual cause is the diffusion of atmospheric particles into the metal at the extremes of the operating temperature. Another cause is impurities and chemicals from the insulation diffusing into the thermocouple wire. If operating at high temperatures, check the specifications of the probe insulation.

Noise: The output from a thermocouple is a small and is vulnerable to electrical noise. Noise mitigation includes integrating (that is, low-pass filtering) and shielding. If operating in an extremely noisy environment, (such as near a large motor) consider using a screened extension cable.

Source: **picotech**