

Names _____

Objective: To experimentally determine the relationships between torque, pf, and η , for an induction motor.

Deliverables: A completed procedure, an attached sheet showing experimental data and necessary calculations, and a graph with the following plots: torque vs slip, pf vs slip, and η vs slip.

Procedure: In this laboratory, you will experimentally measure the performance characteristics of the 3 ϕ induction machine.

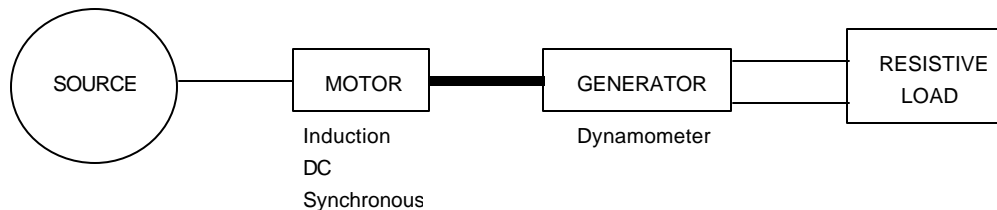

Figure 1. Electromechanical Energy Conversion.

The electrical energy generated by the generator is dissipated in the resistive load. The torque produced by the generator can be displayed by the electronic LCD torque indicator and the speed is measured by counting the visible light pulses reflected from the tape on the machine shaft coupling. The speed is displayed by the red LED display.

Set all power supplies to zero volts and calibrate the torque indicator to read zero. Confirm that the generator is connected as shown in Figure 2. Note that the output is connected to the resistive load box.

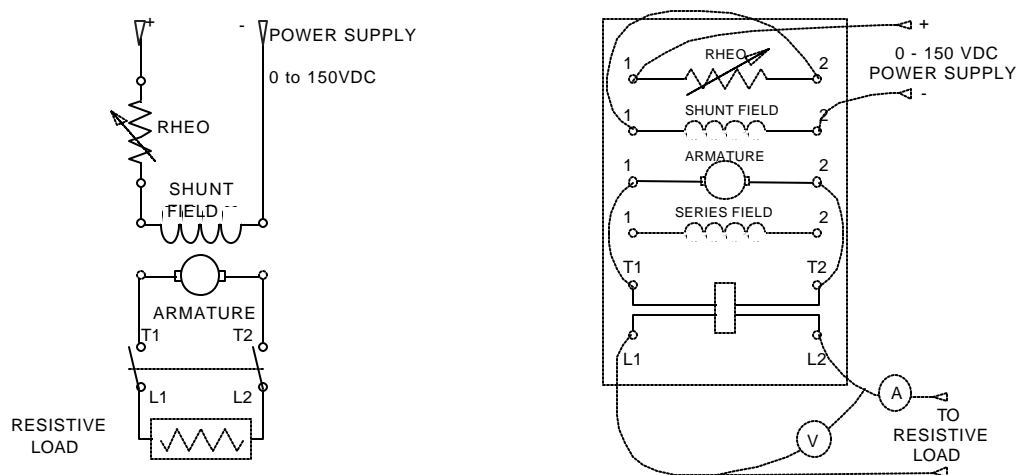

Figure 2. DC Generator Connection.

Confirm that the induction motor is connected to the variable three-phase power supply as shown in Figure 3. The ammeter and voltmeter readings are provided by the Yokogawa meter. Ensure that all Yokogawa readings are in the S mode.

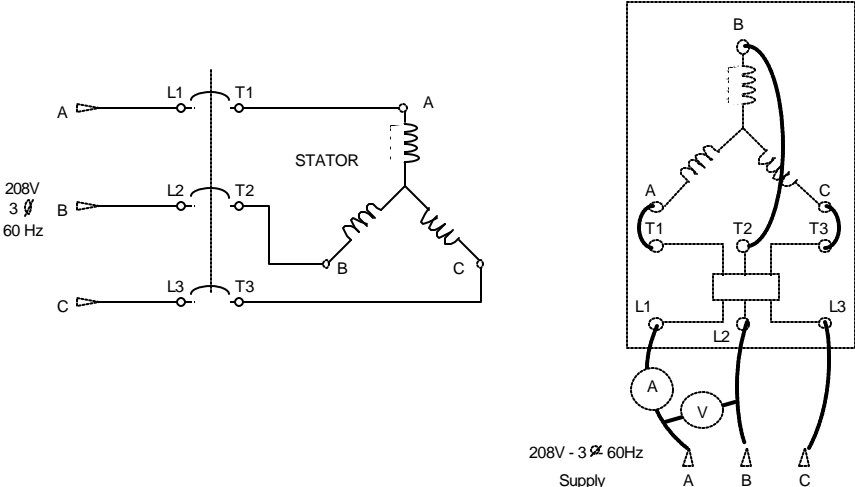

Figure 3. Three-Phase Induction Motor Connection.

Slowly increase the ac voltage until the Yokogawa indicates 120 V line-to-neutral. Pay attention to the speed of the induction motor. Also, note the torque. This torque is due to the friction and windage losses of the generator.

Start increasing the generator dc field voltage (0-150 V supply) with all load resistance switches off (down). When the armature voltage reaches 125 V dc switch on the first set of 3 resistors (150 Ω, 300 Ω, 600 Ω) and complete the first row of the results table. Repeat for the additional sets of 3 resistors.

In the last step [3 x (150//300//600)], the motor-generator will be a bit overloaded, so take your readings without delay and then remove the overload by switching the resistive load off.

Yokogawa measures phase currents and voltages (for Y) and total 3φ power.

Parallel Load Ω	Shaft			Motor				Slip s
	Speed RPM	Rad/s	Torque Nm	Power in	Power out	η %	pf	
1 x (150//300//600)								
2 x (150//300//600)								
3 x (150//300//600)								

Plot the required graphs in MS EXCEL. Since all three curves should pass through the origin (0,0), add this point to your data prior to plotting the curves with EXCEL.

Discuss each graph in a paragraph or two. First relate the predicted shapes to the physics of the motor, and then compare each graph obtained from experiment and its agreement/disagreement to the predicted trends.