

CSSE 230 Day 5

Abstract Data Types
Data Structure “Grand Tour”
Java Collections

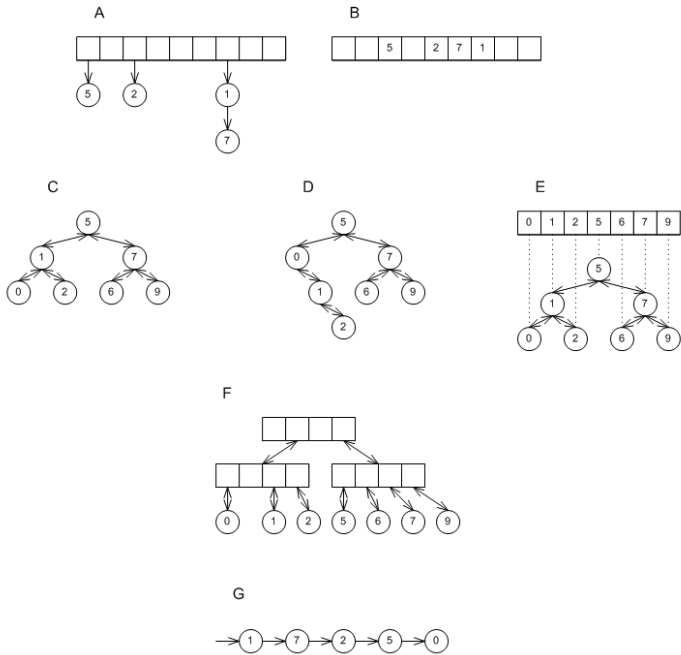

Announcements

- ▶ Stacks and Queues
 - Ideally, you have met with your partner to start
 - Try your best to work well together, even if you have different amounts of programming experience.
- ▶ Finish day 4 + quiz with instructor if needed.
- ▶ Exam 1: next Wednesday, 7–9pm.

How is Homework 2 coming?

- ▶ From question 2:

Suppose $T_1(N)$ is $O(f(N))$ and $T_2(N)$ is $O(f(N))$. **Prove** that $T_1(N) + T_2(N)$ is $O(f(N))$ or give a counter-example.

- Hint: Supposing $T_1(N)$ and $T_2(N)$ are $O(f(N))$, that means there exist constants c_1, c_2, n_1, n_2 , such that.....
 - How can you use them?
-
- ▶ What about the similar question for $T_1(N) - T_2(N)$?
 - Remember, O isn't a tight bound.

After today, you should be able to...

- ▶ explain what an Abstract Data Type (ADT) is
- ▶ List examples of ADTs in the Collections framework (from HW2 #1)
- ▶ List examples of data structures that implement the ADTs in the Collections framework
- ▶ Choose an ADT and data structure to solve a problem

ADTs and Data Structures

A *data type* is an interpretation of data (bits)



- “What is this data, and how does it work?”
- Primitive types (**int**, **double**): hardware-based
- Objects (such as **java.math.BigInteger**): require software interpretation
- Composite types (**int[]**): software + hardware

What is an Abstract Data Type (ADT)?

- ▶ A mathematical model of a data type
- ▶ Specifies:
 - The type of data stored (but not *how* it's stored)
 - The operations supported
 - Argument types and return types of these operations (but not *how* they are implemented)

An Example ADT: Stack

- ▶ Three basic operations:
 - **isEmpty**
 - **push**
 - **pop**
- ▶ Derived operations include **peek** (a.k.a. **top**)
 - How could we write it in terms of the basic operations?
 - We could have **peek** be a basic operation instead.
 - Advantages of each approach?
- ▶ Possible implementations:
 - Use a linked list.
 - Use a growable array.
 - Last time, we talked about implementation details for each.

ADTs for collections of items

Application:
“how can you use it?”

Specification
“what can it do?”

Implementation:
“How is it built?”

```
public static void main(String[] args) {
    Scanner scanner = new Scanner(System.in);
    ArrayList<SingleDie> dice = new ArrayList<SingleDie>();
    while (true) {
        System.out.printf("How many sides (Q to quit):");
        String response = scanner.next();
        if (Character.toUpperCase(response.charAt(0)) == 'Q') {
            break;
        }
        int nSides = Integer.parseInt(response);
        nSides = (nSides < 4) ? 4: nSides;
        dice.add(new SingleDie(nSides));
    }

    scanner.close();
    int minSum = dice.size();
    int maxSum = 0;
    for (SingleDie die : dice) {
        maxSum += die.getNSides();
    }
}
```

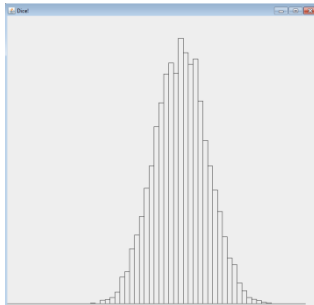

Modifier and Type	Method and De
boolean	add(E e) Appends the s
void	add(int inde Inserts the spe operation).
boolean	addAll(Collec Appends all of in the order th (optional ope
boolean	addAll(int Inserts all of th specified posi
void	clear() Removes all of
boolean	contains(Object Returns true if
boolean	containsAll(C Returns true if
boolean	equals(Object Compares the :
E	get(int inde Returns the ele

```
public class ArrayList<E> extends AbstractList<E>
    implements List<E>, RandomAccess, Cloneabl
{
    private static final long serialVersionUID = 8
    /**
    private transient Object[] elementData;
    /**
    private int size;
    /**
    public ArrayList(int initialCapacity) {
        super();
        if (initialCapacity < 0)
            throw new IllegalArgumentException("Il
            ini
        this.elementData = new Object[initialCapac
    }
    /**
    public ArrayList() {
        this(10);
    }
}
```

CSSE220

CSSE230

Common collection ADTs and implementations (data structures!)

- ▶ List
 - Array List
 - Linked List
- ▶ Stack
- ▶ Queue
- ▶ Set
 - Tree Set
 - Hash Set
 - Linked Hash Set

- ▶ Map
 - Tree Map
 - Hash Map
- ▶ Priority Queue

Underlying data structures for many
Array
Tree

Implementations for almost all of these* are provided by the **Java Collections Framework** in the **java.util** package.

Java Collections Framework

Reminder: Available, efficient, bug-free implementations of many key data structures

Most classes are in `java.util`

You started this in HW2 #1; Weiss Chapter 6 has more details

Array

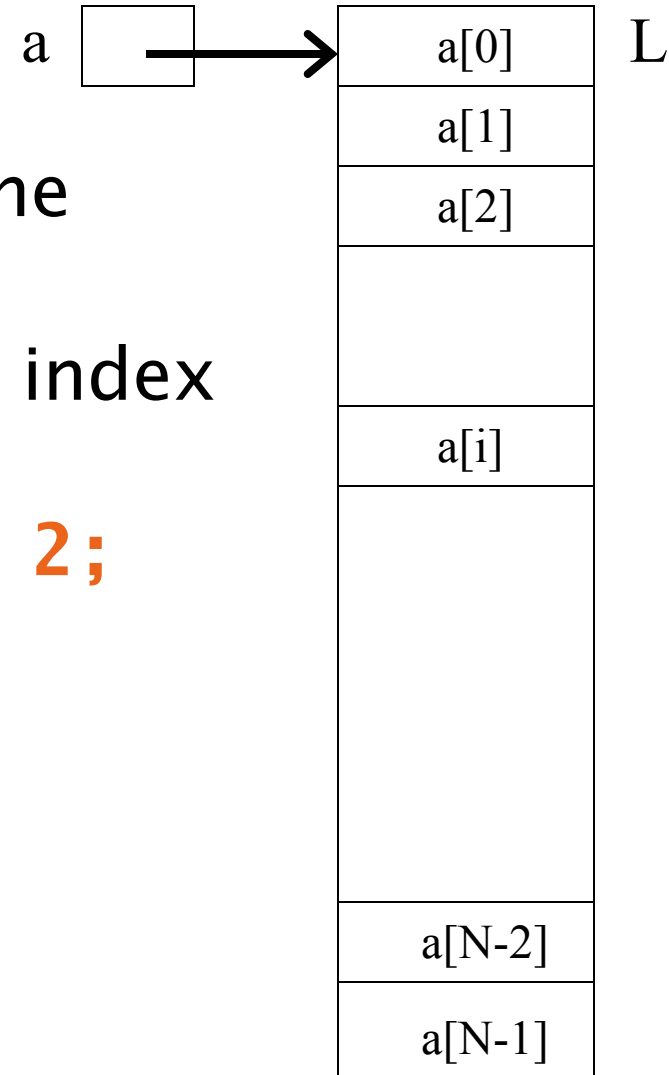

- ▶ Size must be declared when the array is constructed
- ▶ Can look up or store items by index

Example:

```
nums[i+1] = nums[i] + 2;
```

- ▶ How is this done?

List

- ▶ A list is an ordered collection where elements may be added anywhere, and any elements may be deleted or replaced.
- ▶ **Array List:** Like an array, but growable and shrinkable.
- ▶ **Linked List:**

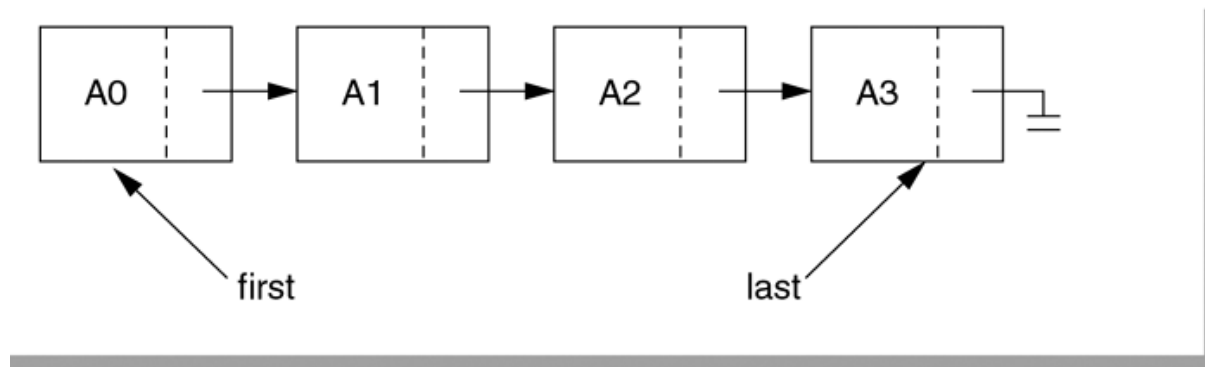

figure 6.19
A simple linked list

Array Lists and Linked Lists

Operations Provided	Array List Efficiency	Linked List Efficiency
Random access	$O(1)$	$O(n)$
Add/remove item	$O(n)$	$O(1)$

Stack

- ▶ A last-in, first-out (LIFO) data structure

- ▶ Real-world stacks

- Plate dispensers in the cafeteria
- Pancakes!

- ▶ Some uses:

- Tracking paths through a maze
- Providing “unlimited undo” in an application

```
public static void printInReverse(List<String> words) {  
    // TODO: implement  
    Stack<String> stack = new Stack<String>();  
    for (String w : words) {  
        stack.push(w);  
    }  
    while (!stack.isEmpty()) {  
        System.out.println(stack.pop());  
    }  
}
```

Operations Provided	Efficiency
Push item	O(1)
Pop item	O(1)

Implemented by
Stack, **LinkedList**,
and **ArrayDeque** in
Java

Queue

- ▶ first-in, first-out (FIFO)

data structure

- ▶ Real-world queues

- Waiting line at the BMW
- Character on Star Trek TNG

- ▶ Some uses:

- Scheduling access to shared resource (e.g., printer)

```
/**
 * Uses a queue to print pairs of words consisting of
 * a word in the input and the word that appeared five
 * words before it.
 *
 * @param words
 */
public static void printCurrentAndPreceding(List<String> words) {
    // TODO: implement
    ArrayDeque<String> queue = new ArrayDeque<String>();
    // Preloads the queue:
    for (int i = 0; i < 5; i++) {
        queue.add("NotAWord");
    }
    for (String w : words) {
        queue.add(w);
        String fiveAgo = queue.remove();
        System.out.println(w + ", " + fiveAgo);
    }
}
```

Operations Provided	Efficiency
Enqueue item	O(1)
Dequeue item	O(1)

Implemented by
LinkedList and
ArrayDeque in
Java

Set

- ▶ A collection of items **without duplicates** (in general, order does not matter)
 - If **a** and **b** are both in set, then **!a.equals(b)**
- ▶ Real-world sets:
 - Students
 - Collectibles
- ▶ One possible use:
 - Quickly checking if an item is in a collection

```
public static void printSortedWords(List<String> words) {  
    TreeSet<String> ts = new TreeSet<String>();  
    for (String w : words) {  
        ts.add(w);  
    }  
    for (String s : ts) {  
        System.out.println(s);  
    }  
}
```

Example from 220

Operations	HashSet	TreeSet
Add/remove item	amort. $O(1)$, worst $O(n)$	$O(\log n)$
Contains?	$O(1)$	$O(\log n)$

Sorts items!



Map

How is a TreeMap like a TreeSet?
How is it different?

- ▶ Associate **keys** with **values**
- ▶ Real-world “maps”
 - Dictionary
 - Phone book
- ▶ Some uses:
 - Associating student ID with transcript
 - Associating name with high scores

Operations	HashMap	TreeMap
Insert key-value pair	amort. $O(1)$, worst $O(n)$	$O(\log n)$
Look up the value associated with a given key	$O(1)$	$O(\log n)$

Sorts items by key!

HashMap/HashSet Example (220)

```
public static void printWordCountsByLength(List<String> words) {
    HashMap<Integer, HashSet<String>> map =
        new HashMap<Integer, HashSet<String>>();

    for (String w : words) {
        int len = w.length();
        HashSet<String> set;
        if (map.containsKey(len)) {
            set = map.get(len);
        } else {
            set = new HashSet<String>();
            map.put(len, set);
        }
        set.add(w);
    }
    System.out.printf("%d unique words of length 3.%n", getCount(map, 3));
    System.out.printf("%d unique words of length 7.%n", getCount(map, 7));
    System.out.printf("%d unique words of length 9.%n", getCount(map, 9));
    System.out.printf("%d unique words of length 15.%n", getCount(map, 15));
}
```

```
public static int getCount(HashMap<Integer, HashSet<String>> map, int key) {
    if (map.containsKey(key)) {
        return map.get(key).size();
    } else {
        return 0;
    }
}
```

Priority Queue

Not like regular queues!

- ▶ Each **item** stored **has an** associated **priority**
 - Only item with “minimum” priority is accessible
 - Operations: **insert**, **findMin**, **deleteMin**
- ▶ Real-world “priority queue”:
 - Airport ticketing counter
- ▶ Some uses
 - Simulations
 - Scheduling in an OS
 - Huffman coding

```
PriorityQueue<String> stringQueue =  
    new PriorityQueue<String>();
```

```
stringQueue.add("ab");  
stringQueue.add("abcd");  
stringQueue.add("abc");  
stringQueue.add("a");
```

```
while(stringQueue.size() > 0)  
    System.out.println(stringQueue.remove());
```

Assumes a binary heap implementation.
The version in Warm Up and Stretching isn't this efficient.

Operations Provided	Efficiency
Insert	$O(\log n)$
Find Min	$O(1)$
Delete Min	$O(\log n)$

Trees, Not Just For Sorting

- ▶ Collection of nodes
 - One specialized node is the root.
 - A node has one parent (unless it is the root)
 - A node has zero or more children.
- ▶ Real-world “trees”:
 - Organizational hierarchies
 - Some family trees
- ▶ Some uses:
 - Directory structure on a hard drive
 - Sorted collections

Only if tree is
“balanced”

Operations Provided	Efficiency
Find	$O(\log n)$
Add/remove	$O(\log n)$

Graphs

- ▶ A collection of nodes and edges
 - Each edge joins two nodes
 - Edges can be directed or undirected
- ▶ Real-world “graph”:
 - Road map
- ▶ Some uses:
 - Tracking links between web pages
 - Facebook

Operations Provided	Efficiency
Find	$O(n)$
Add/remove	$O(1)$ or $O(n)$ or $O(n^2)$

Depends on implementation
(time/space trade off)

Networks

- ▶ Graph whose edges have numeric labels
- ▶ Examples (labels):
 - Road map (mileage)
 - Airline's flight map (flying time)
 - Plumbing system (gallons per minute)
 - Computer network (bits/second)
- ▶ Famous problems:
 - Shortest path
 - Maximum flow
 - Minimal spanning tree
 - Traveling salesman
 - Four-coloring problem for planar graphs

Common ADTs

- ▶ Array
- ▶ List
 - Array List
 - Linked List
- ▶ Stack
- ▶ Queue
- ▶ Set
 - Tree Set
 - Hash Set
- ▶ Map
 - Tree Map
 - Hash Map
- ▶ Priority Queue
- ▶ Tree
- ▶ Graph

We'll implement and use nearly all of these, some multiple ways. And a few other data structures.

Data Structure Summary

Structure	find	insert/remove	Comments
Array	$O(n)$	can't do it	Constant-time access by position
Stack	top only $O(1)$	top only $O(1)$	Easy to implement as an array.
Queue	front only $O(1)$	$O(1)$	insert rear, remove front.
ArrayList	$O(\log N)$	$O(N)$	Constant-time access by position Add at end: am. $O(1)$, worst $O(N)$
Linked List	$O(N)$	$O(1)$	$O(N)$ to find insertion position.
HashSet/Map	$O(1)$	amort. $O(1)$, worst $O(N)$	Not traversable in sorted order
TreeSet/Map	$O(\log N)$	$O(\log N)$	Traversable in sorted order
PriorityQueue	$O(1)$	$O(\log N)$	Can only find/remove smallest
Search Tree	$O(\log N)$	$O(\log N)$	If tree is balanced, $O(N)$ otherwise

Often, one particular ADT and implementation is best for the problem

- ▶ Which ADT to use?
 - It depends. How do you access your data? By position? By key? Do you need to iterate through it? Do you need the min/max?
- ▶ Which implementation to use?
 - It also depends. How important is fast access vs fast add/remove? Does the data need to be ordered in any way? How much space do you have?
- ▶ But real life is often messier...

How to figure this out?

- ▶ Use Java's Collections Framework.
 - Search for *Java 8 Collection*
 - With a partner, read the javadocs to answer the quiz questions. You only need to submit one quiz per pair. (Put both names at top)
- ▶ If you finish, you may work on your current CSSE230 assignments