

CSSE 230 Day 5

Abstract Data Types
Data Structure “Grand Tour”
Java Collections

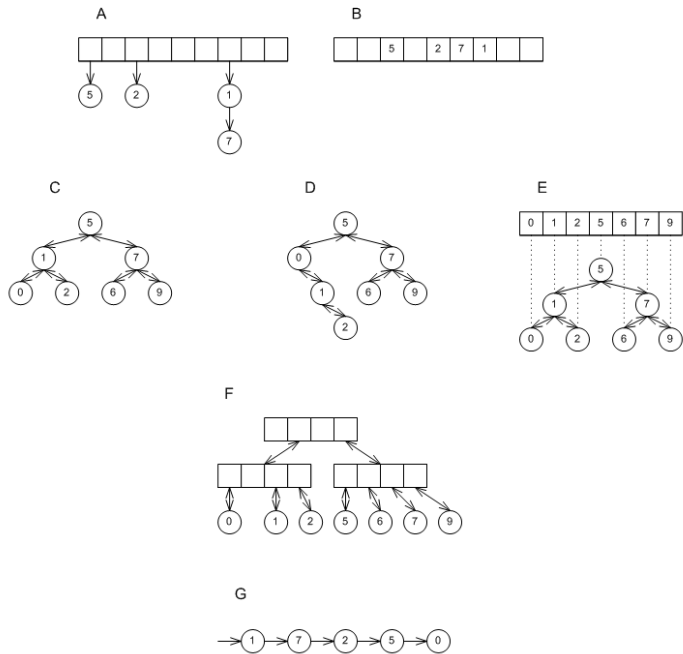

Questions?

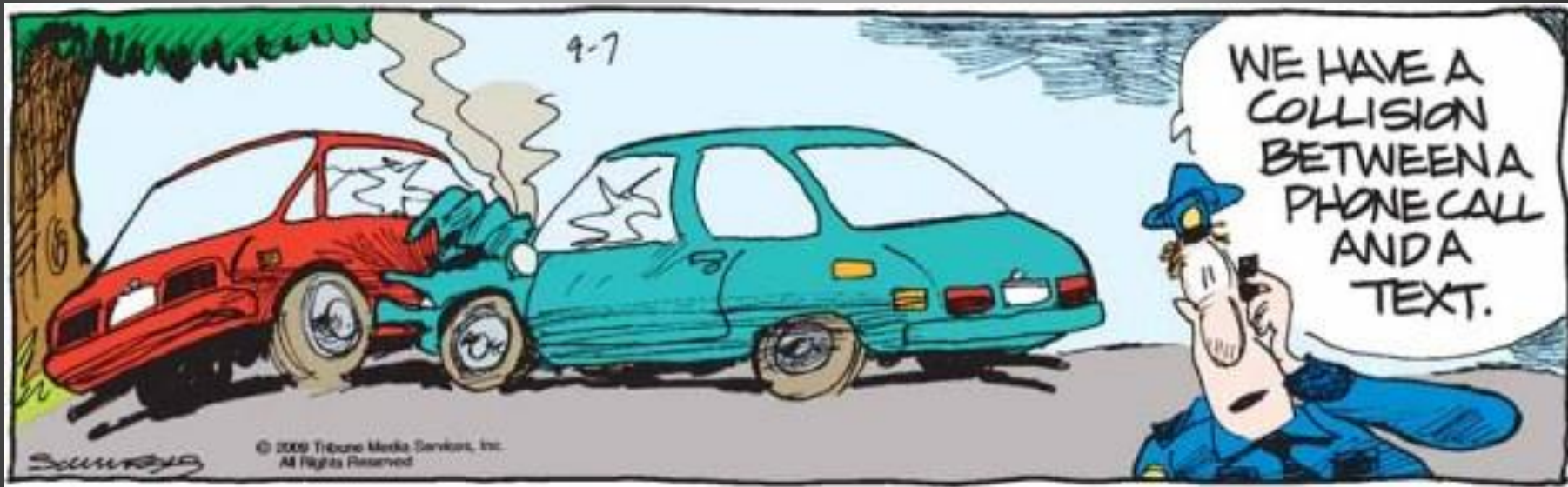

How is Homework 2?

- ▶ Suppose $T_1(N)$ is $O(f(N))$ and $T_2(N)$ is $O(f(N))$.
Prove that $T_1(N) + T_2(N)$ is $O(f(N))$
- ▶ Hint: Constants c_1 and c_2 must exist for $T_1(N)$ and $T_2(N)$ to be $O(f(N))$
 - How can you use them?

After today, you should be able to...

- ▶ explain what an ADT is
- ▶ list four examples of ADTs in the Collections framework
- ▶ list examples of implementations of the ADTs in the Collections framework
- ▶ explain why stacks and queues are still good ADTs to use, even though lists could be used.

ADTs and Data Structures

What is data?

What do we mean by
structure?

A *data type* is an interpretation of bits

- A set of operations
- May be provided by the hardware (**int** and **double**)
- By software (**java.math.BigInteger**)
- By software + hardware (**int[]**)



What is an Abstract Data Type (ADT)?

- ▶ A mathematical model of a data type
- ▶ Specifies:
 - The type of data stored
 - The operations supported
 - Argument types and return types of these operations
 - What each operation does, but not how

An Example ADT: Non-negative integers

- ▶ One special value: **zero**
- ▶ Three basic operations:
 - **succ**
 - **pred**
 - **isZero**
- ▶ Derived operations include **plus**
- ▶ Sample rules:
 - **isZero(succ(n)) → false**
 - **pred(succ(n)) → n**
 - **plus(n, zero) → n**
 - **plus(n, succ(m)) → succ(plus(n, m))**

Data Structures are ADTs for collections of items

Application:
“how can you use that?”

Specification
“what is it?”

Implementation:
“How do you do that?”

```
public static void main(String[] args) {
    Scanner scanner = new Scanner(System.in);
    ArrayList<SingleDie> dice = new ArrayList<SingleDie>();
    while (true) {
        System.out.printf("How many sides (Q to quit):");
        String response = scanner.next();
        if (Character.toUpperCase(response.charAt(0)) == 'Q') {
            break;
        }
        int nSides = Integer.parseInt(response);
        nSides = (nSides < 4) ? 4: nSides;
        dice.add(new SingleDie(nSides));
    }

    scanner.close();
    int minSum = dice.size();
    int maxSum = 0;
    for (SingleDie die : dice) {
        maxSum += die.getNSides();
    }
}
```

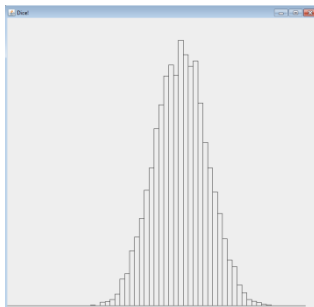

Constructor Summary

- `ArrayList()`
Constructs an empty list with:
- `ArrayList(Collection<? extend E> c)`
Constructs a list containing the elements of the collection.
- `ArrayList(int initialCapacity)`
Constructs an empty list with the specified initial capacity.

Method Summary

- `boolean add(E e)`
Appends the specified element to the end of this list.
- `void add(int index, E element)`
Inserts the specified element at the position indicated by the index.
- `boolean addAll(Collection<? extends E> c)`
Appends all of the elements in the collection to the end of this list, in the order that they are returned by the collection's iterator.
- `boolean addAll(int index, Collection<? extends E> c)`
Inserts all of the elements in the collection into this list at the position indicated by the index.
- `void clear()`
Removes all of the elements from this list.

```
public class ArrayList<E> extends AbstractList<E>
    implements List<E>, RandomAccess, Cloneable {
    private static final long serialVersionUID = 8
    /**
     * private transient Object[] elementData;
     * private int size;
     *
     * public ArrayList(int initialCapacity) {
     *     super();
     *     if (initialCapacity < 0)
     *         throw new IllegalArgumentException("Il
     *         ini
     *         this.elementData = new Object[initialCapac
     *     }
     * /**
     * public ArrayList() {
     *     this(10);
     * }
     }
```

CSSE220

CSSE230

Data Structures Grand Tour

Some review

Some new

All will appear again

Common ADTs

- ▶ Array
- ▶ List
 - Array List
 - Linked List
- ▶ Stack
- ▶ Queue
- ▶ Set
 - Tree Set
 - Hash Set
 - Linked Hash Set
- ▶ Map
 - Tree Map
 - Hash Map
- ▶ Priority Queue
- ▶ Tree
- ▶ Graph
- ▶ Network

Implementations for almost all of these* are provided by the **Java Collections Framework** in the **java.util** package.

*Exceptions: Tree, Graph, Network

Explore Java's Collection framework

- ▶ Search for *Java 7 Collection*
- ▶ With a partner, read the javadocs to answer the quiz questions. You only need to submit one quiz per pair. (Put both names at top)
- ▶ I have used the rest of the slide when teaching CSSE230 before.
 - Maybe a good reference?
- ▶ When you finish, you may work on your current CSSE230 assignments

Array

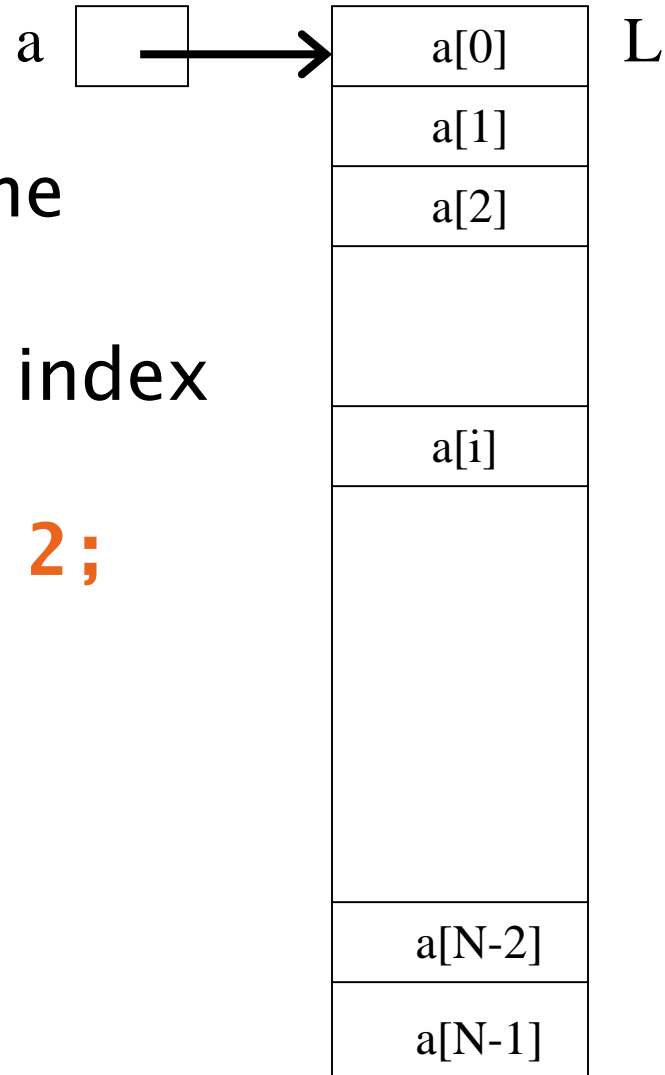

- ▶ Size must be declared when the array is constructed
 - ▶ Can look up or store items by index
- Example:

```
nums[i+1] = nums[i] + 2;
```

- ▶ How is this done?

List

- ▶ A list is an ordered collection where elements may be added anywhere, and any elements may be deleted or replaced.
- ▶ **Array List:** Like an array, but growable and shrinkable.
- ▶ **Linked List:**

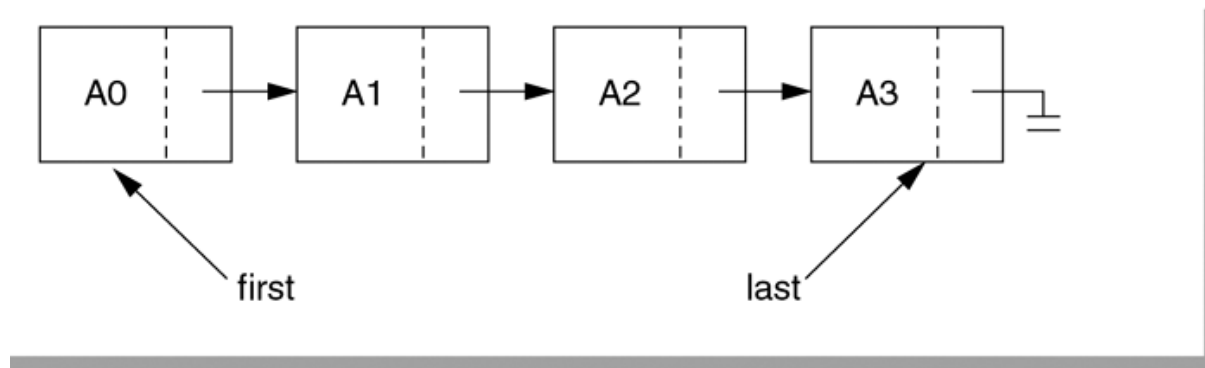

figure 6.19
A simple linked list

Array Lists and Linked Lists

Operations Provided	Array List Efficiency	Linked List Efficiency
Random access	$O(1)$	$O(n)$
Add/remove item	$O(n)$	$O(1)$

Stack

- ▶ A last-in, first-out (LIFO) data structure

- ▶ Real-world stacks

- Plate dispensers in the cafeteria
- Pancakes!

- ▶ Some uses:

- Tracking paths through a maze
- Providing “unlimited undo” in an application

```
public static void printInReverse(List<String> words) {  
    // TODO: implement  
    Stack<String> stack = new Stack<String>();  
    for (String w : words) {  
        stack.push(w);  
    }  
    while (!stack.isEmpty()) {  
        System.out.println(stack.pop());  
    }  
}
```

Operations Provided	Efficiency
Push item	O(1)
Pop item	O(1)

Implemented by
Stack, **LinkedList**,
and **ArrayDeque** in
Java

Queue

- ▶ first-in, first-out (FIFO)

data structure

- ▶ Real-world queues

- Waiting line at the BMW
- Character on Star Trek TNG

- ▶ Some uses:

- Scheduling access to shared resource (e.g., printer)

```
/**
 * Uses a queue to print pairs of words consisting of
 * a word in the input and the word that appeared five
 * words before it.
 *
 * @param words
 */
public static void printCurrentAndPreceding(List<String> words) {
    // TODO: implement
    ArrayDeque<String> queue = new ArrayDeque<String>();
    // Preloads the queue:
    for (int i = 0; i < 5; i++) {
        queue.add("NotAWord");
    }
    for (String w : words) {
        queue.add(w);
        String fiveAgo = queue.remove();
        System.out.println(w + ", " + fiveAgo);
    }
}
```

Operations Provided	Efficiency
Enqueue item	O(1)
Dequeue item	O(1)

Implemented by **LinkedList** and **ArrayDeque** in Java

Set

- ▶ A collection of items **without duplicates** (in general, order does not matter)
 - If **a** and **b** are both in set, then **!a.equals(b)**
- ▶ Real-world sets:
 - Students
 - Collectibles
- ▶ One possible use:
 - Quickly checking if an item is in a collection

```
public static void printSortedWords(List<String> words) {  
    TreeSet<String> ts = new TreeSet<String>();  
    for (String w : words) {  
        ts.add(w);  
    }  
    for (String s : ts) {  
        System.out.println(s);  
    }  
}
```

Example from 220

Operations	HashSet	TreeSet
Add/remove item	O(1)	O(log n)
Contains?	O(1)	O(log n)

Can hog space

Sorts items!

Map

How is a TreeMap like a TreeSet?
How is it different?

- ▶ Associate **keys** with **values**
- ▶ Real-world “maps”
 - Dictionary
 - Phone book
- ▶ Some uses:
 - Associating student ID with transcript
 - Associating name with high scores

Operations	HashMap	TreeMap
Insert key-value pair	$O(1)$	$O(\log n)$
Look up the value associated with a given key	$O(1)$	$O(\log n)$

Can hog space

Sorts items by key!

HashMap/HashSet Example (220)

```
public static void printWordCountsByLength(List<String> words) {
    HashMap<Integer, HashSet<String>> map =
        new HashMap<Integer, HashSet<String>>();

    for (String w : words) {
        int len = w.length();
        HashSet<String> set;
        if (map.containsKey(len)) {
            set = map.get(len);
        } else {
            set = new HashSet<String>();
            map.put(len, set);
        }
        set.add(w);
    }
    System.out.printf("%d unique words of length 3.%n", getCount(map, 3));
    System.out.printf("%d unique words of length 7.%n", getCount(map, 7));
    System.out.printf("%d unique words of length 9.%n", getCount(map, 9));
    System.out.printf("%d unique words of length 15.%n", getCount(map, 15));
}
```

```
public static int getCount(HashMap<Integer, HashSet<String>> map, int key) {
    if (map.containsKey(key)) {
        return map.get(key).size();
    } else {
        return 0;
    }
}
```

Priority Queue

Not like regular queues!

- ▶ Each **item** stored **has an** associated **priority**
 - Only item with “minimum” priority is accessible
 - Operations: **insert**, **findMin**, **deleteMin**
- ▶ Real-world “priority queue”:
 - Airport ticketing counter
- ▶ Some uses
 - Simulations
 - Scheduling in an OS
 - Huffman coding

```
PriorityQueue<String> stringQueue =  
    new PriorityQueue<String>();
```

```
stringQueue.add("ab");  
stringQueue.add("abcd");  
stringQueue.add("abc");  
stringQueue.add("a");
```

```
while(stringQueue.size() > 0)  
    System.out.println(stringQueue.remove());
```

The version in Warm Up and Stretching isn't this efficient.

Operations Provided	Efficiency
Insert	$O(\log n)$
Find Min	$O(\log n)$
Delete Min	$O(\log n)$

Trees, Not Just For Sorting

- ▶ Collection of nodes
 - One specialized node is the root.
 - A node has one parent (unless it is the root)
 - A node has zero or more children.
- ▶ Real-world “trees”:
 - Organizational hierarchies
 - Some family trees
- ▶ Some uses:
 - Directory structure on a hard drive
 - Sorted collections

Only if tree is
“balanced”

Operations Provided	Efficiency
Find	$O(\log n)$
Add/remove	$O(\log n)$

Graphs

- ▶ A collection of nodes and edges
 - Each edge joins two nodes
 - Edges can be directed or undirected
- ▶ Real-world “graph”:
 - Road map
- ▶ Some uses:
 - Tracking links between web pages
 - Facebook

Operations Provided	Efficiency
Find	$O(n)$
Add/remove	$O(1)$ or $O(n)$ or $O(n^2)$

Depends on implementation (time/space trade off)

Networks

- ▶ Graph whose edges have numeric labels
- ▶ Examples (labels):
 - Road map (mileage)
 - Airline's flight map (flying time)
 - Plumbing system (gallons per minute)
 - Computer network (bits/second)
- ▶ Famous problems:
 - Shortest path
 - Maximum flow
 - Minimal spanning tree
 - Traveling salesman
 - Four-coloring problem for planar graphs

Common ADTs

- ▶ Array
- ▶ List
 - Array List
 - Linked List
- ▶ Stack
- ▶ Queue
- ▶ Set
 - Tree Set
 - Hash Set
- ▶ Map
 - Tree Map
 - Hash Map
- ▶ Priority Queue
- ▶ Tree
- ▶ Graph
- ▶ Network

We'll implement and use nearly all of these, some multiple ways. And a few other data structures.

Data Structure Summary

Structure	find	insert/remove	Comments
Array	$O(n)$	can't do it	Constant-time access by position
Stack	top only $O(1)$	top only $O(1)$	Easy to implement as an array.
Queue	front only $O(1)$	$O(1)$	insert rear, remove front.
ArrayList	$O(\log N)$	$O(N)$	Constant-time access by position
Linked List	$O(n)$	$O(1)$	$O(N)$ to find insertion position.
HashSet/Map	$O(1)$	$O(1)$	If table not very full
TreeSet/Map	$O(\log N)$	$O(\log N)$	Kept in sorted order
PriorityQueue	$O(\log N)$	$O(\log N)$	Can only find/remove smallest
Tree	$O(\log N)$	$O(\log N)$	If tree is balanced
Graph	$O(N*M)$?	$O(M)$?	N nodes, M edges
Network			shortest path, maxFlow

Work Time

If we have time left