

1. CREATING AND MESHING BASIC GEOMETRY

This tutorial illustrates geometry creation and mesh generation for a simple geometry using GAMBIT.

In this tutorial you will learn how to:

- Start GAMBIT
- Use the **Operation** toolpad
- Create a brick and an elliptical cylinder
- Unite two volumes
- Manipulate the display of your model
- Mesh a volume
- Examine the quality of the mesh
- Save the session and exit GAMBIT

1.1 Prerequisites

This tutorial assumes you have no prior experience of working with GAMBIT. You should, however, read Chapter 0, “Using This Tutorial Guide,” to familiarize yourself with the GAMBIT interface and with conventions used in the tutorial instructions.

1.2 Problem Description

The model consists of an intersecting brick and elliptical cylinder. The basic geometry is shown schematically in Figure 1-1.

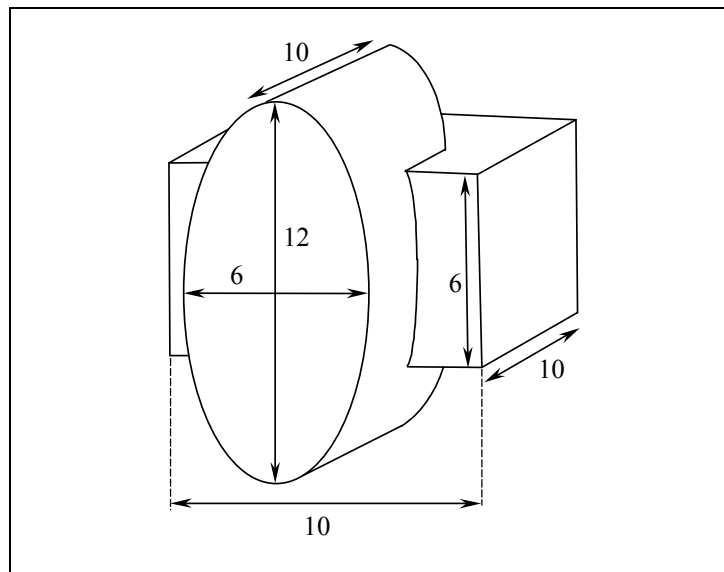

Figure 1-1: Problem specification

1.3 Strategy

This first tutorial illustrates some of the basic operations for generating a mesh using GAMBIT. In particular, it demonstrates:

- How to build the geometry easily using the “top-down” solid modeling approach
- How to create a hexahedral mesh automatically

The “top-down” approach means that you will construct the geometry by creating volumes (bricks, cylinders, etc.) and then manipulating them through Boolean operations (unite, subtract, etc.). In this way, you can quickly build complicated shapes without first creating the underlying vertices, edges, and faces.

Once you have built a valid geometry model, you can directly and (in many cases) automatically create the mesh. In this example, the Cooper meshing algorithm is used to automatically create an unstructured, hexahedral mesh. More complicated geometries may require some manual decomposition before you can create the mesh; this is demonstrated in subsequent tutorials.

The steps you will follow in this tutorial are listed below:

- Create two volumes (a brick and an elliptical cylinder).
- Unite the two volumes.
- Automatically generate the mesh.
- Examine the quality of the resulting mesh.

To keep this introductory tutorial short and simple, certain steps that you would normally follow have been omitted:

- Adjusting the distribution of nodes on individual edges of the geometry
- Setting continuum types (for example, identifying which mesh zones are fluid and which are solid) and boundary types

These details, as well as others, are covered in subsequent tutorials.

1.4 Procedure

Type

```
gambit -id basgeom
```

to start GAMBIT.

This command opens the GAMBIT graphical user interface (GUI). (See Figure 1-2.) GAMBIT uses the name you specify (in this example, basgeom) as a prefix to all files it creates: for example, basgeom.jou.

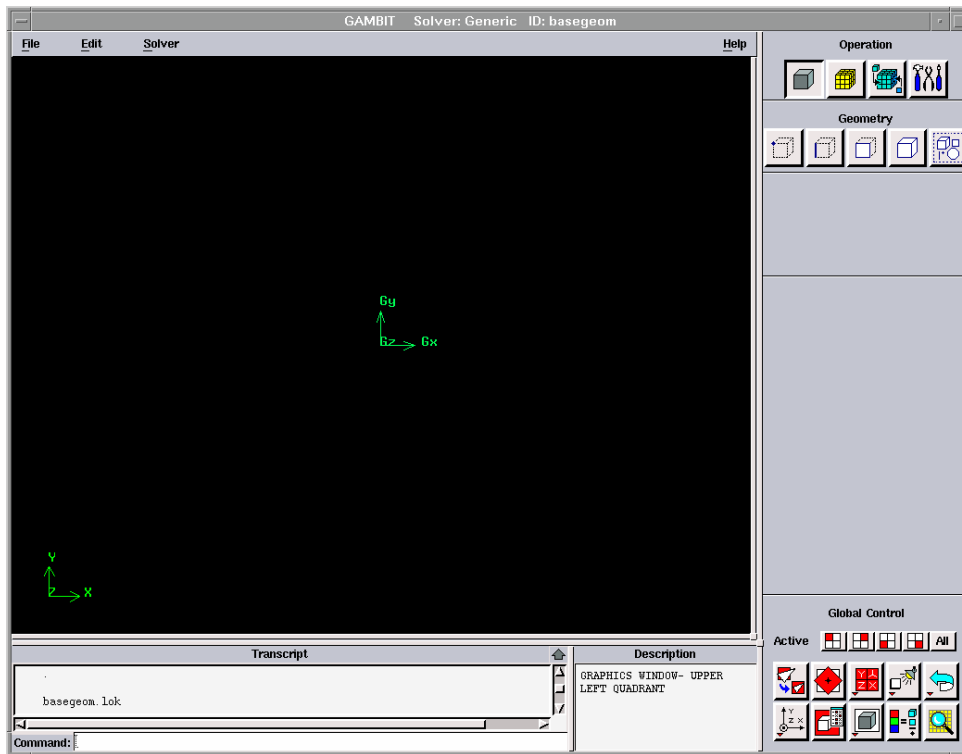



Figure 1-2: The GAMBIT graphical user interface (GUI)

Step 1: Create a Brick

1. Create a brick by doing the following:

- a) In the **Operation** toolpad (located in the top right corner of the GAMBIT GUI),

select the **GEOMETRY**  command button by clicking on it with the left mouse button. If the **Geometry** subpad does not appear when you select the **GEOMETRY** command button, click it again.

*The name of a command button is displayed in the **Description** window at the bottom of the GAMBIT GUI when you hold the mouse cursor over the command button. The **GEOMETRY** command button will appear depressed when it is selected. Selecting the **GEOMETRY** command button opens the **Geometry** subpad. Note that when you first start GAMBIT, the **GEOMETRY** command button is selected by default.*

- b) Use the left mouse button to select the **VOLUME**  command button in the **Geometry** subpad.

*Again, this command button will be depressed when selected. Selecting this command button opens the **Geometry/Volume** subpad.*

- c) Use the left mouse button to select the **CREATE VOLUME**  command button in the **Geometry/Volume** subpad.

*This command sequence opens the **Create Real Brick** form.*

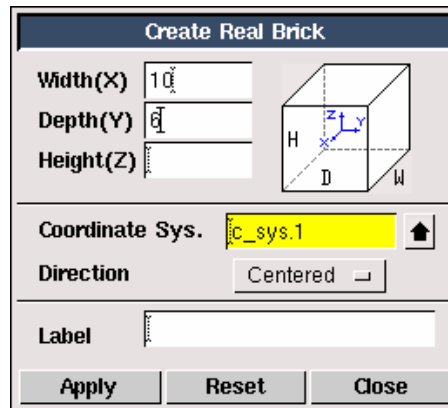

The above description of selecting command buttons can be shortened to the following:



The selection of the command buttons will be represented using this method for the remainder of this tutorial, and in all subsequent tutorials.

- d) Left-click in the text entry box to the right of **Width** in the **Create Real Brick** form, and enter a value of 10 for the **Width** of the brick.
- e) Use the *Tab* key on the keyboard to move to the **Depth** text entry box, and enter 6 for the **Depth** of the brick.

*The text entry box for **Height** can be left blank; GAMBIT will set this value to be the same value as the **Width** by default.*

- f) Select Centered from the option menu to the right of **Direction**.

*NOTE: When you first open the **Create Real Brick** form, the Centered option is selected by default.*

- i) Hold down the left mouse button on the option button to the right of **Direction** until the option menu appears.
- ii) Select Centered from the list.
- g) Click **Apply**.

*A message appears in the **Transcript** window at the bottom left of the GAMBIT GUI to indicate that a volume, called volume.1, was created. The volume will be visible in the graphics window, as shown in Figure 1-3.*

If you make a mistake at any point in the geometry creation process, you can

*use the **UNDO** command button  to undo multiple levels of geometry creation. At this point, you have only performed one operation, so you can only undo one operation.*

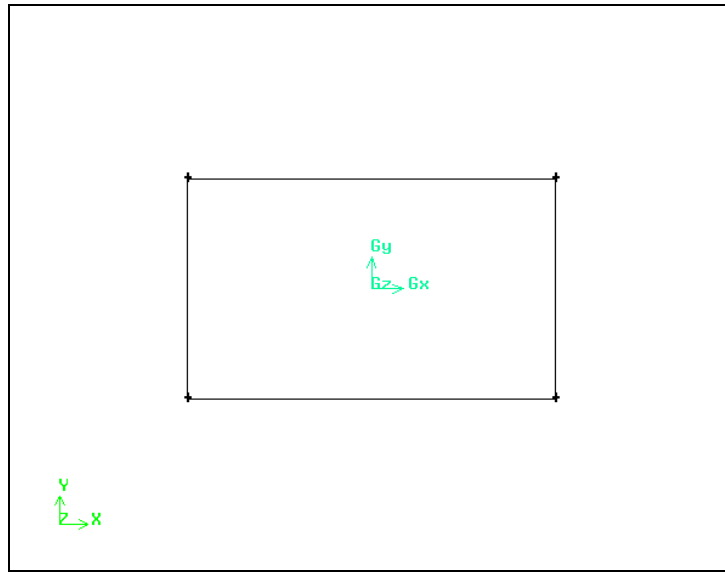



Figure 1-3: Rectangular brick volume (side view)

Step 2: Create an Elliptical Cylinder

1. Create an elliptical cylinder.

a) Hold down the *right* mouse button while the cursor is on the **CREATE VOLUME**  command button.

b) Select the **CREATE REAL CYLINDER** option  from the resulting menu.

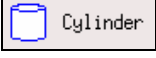
! **CREATE REAL CYLINDER** is the text that is written in the **Description** window when you hold the mouse cursor over the  menu item.

This command sequence opens the **Create Real Cylinder** form.

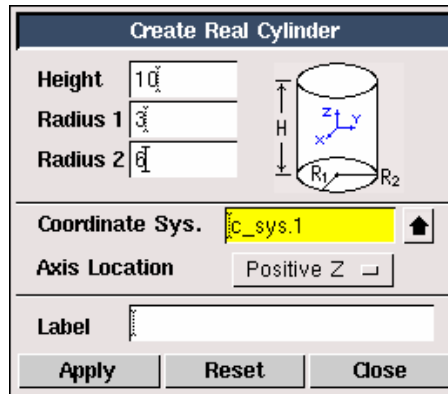

The above method of selecting command buttons can be shortened to the following:

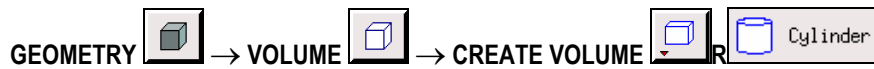

where **R** indicates a toolpad choice using the right mouse button.

- c) Enter a **Height** of 10.
- d) Enter a value of 3 for **Radius 1**.
- e) Enter a value of 6 for **Radius 2**.

- f) Retain the default **Axis Location** of Positive Z.
- g) Click **Apply**.

The brick and elliptical cylinder are shown in Figure 1-4.

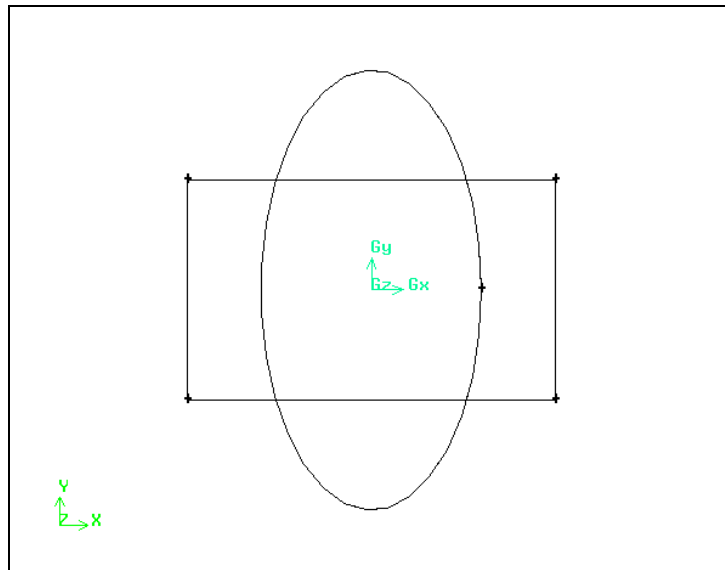
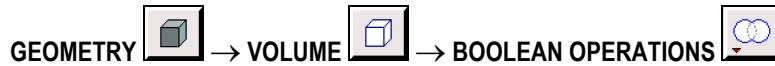

Figure 1-4: Brick and elliptical cylinder

Step 3: Unite the Two Volumes

1. Unite the brick and elliptical cylinder into one volume.



This command sequence opens the **Unite Real Volumes** form.

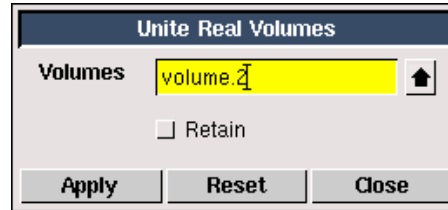

Notice that the **Volumes** list box is yellow in the **Unite Real Volumes** form at this point. The yellow color indicates that this is the active field in the form, and any volume selected will be entered into this box on the form.

- a) Hold down the *Shift* key on the keyboard and select the brick by clicking on one of its edges in the graphics window using the left mouse button.

! *The Shift key must always be held down when selecting entities in the graphics window using the left mouse button. This operation will be referred to as Shift-left-click in all further steps.*

*The brick will appear red in the graphics window and its name (volume.1) will appear in the **Volumes** list box in the **Unite Real Volumes** form.*

- b) Shift-left-click the elliptical cylinder in the graphics window.
- c) Click **Apply** to accept the selection and unite the elliptical cylinder and brick.

! *Alternatively, you could continue to hold down the Shift key and click the right mouse button in the graphics window to accept the selection of the volumes. This method allows you to rapidly accept selections and apply operations with minimal movement of the mouse.*

! *The Shift key must always be held down when clicking the right-mouse button to accept the selection of entities in the graphics window. This operation is referred to as Shift-right-click.*

The volume is shown in Figure 1-5. You can rotate the display (as shown in Figure 1-5) by holding down the left mouse button in the graphics window and moving the mouse to the left. More information on manipulating the graphics display is given in the next step.

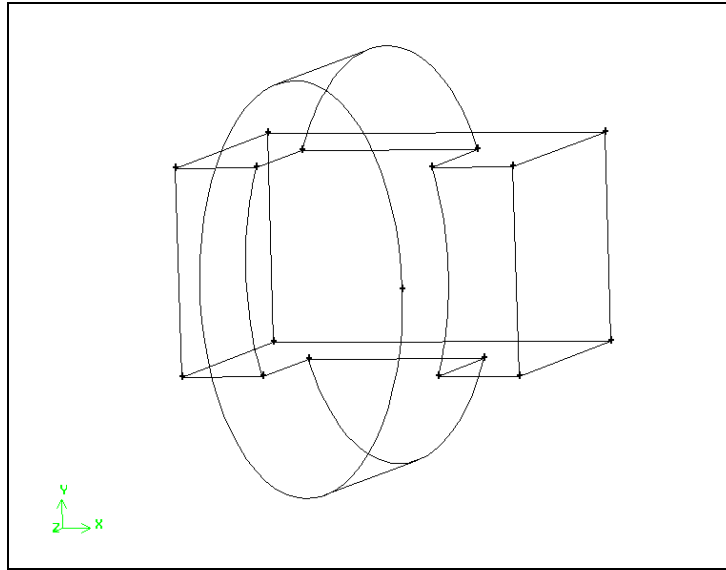



Figure 1-5: Brick and elliptical cylinder united into one volume

Step 4: Manipulate the Display

1. Zoom out from the current view by holding down the right mouse button in the graphics window and pushing the mouse away from you.
2. Rotate the view around the screen center by holding down the right mouse button and moving the mouse from side to side.
3. Rotate the view in free-form mode by holding down the left mouse button and moving the mouse.
4. Translate the display by holding down the middle mouse button and moving the mouse.
5. Divide the graphics window into four quadrants by clicking the **SELECT PRESET**

CONFIGURATION  command button in the **Global Control** toolpad.

GAMBIT divides the graphics window into four quadrants and applies a different orientation to the model in each of the four quadrants. Each view of the graphics window can be manipulated independently. All changes to the model appear in all portions of the graphics window, unless you disable one or more quadrants.

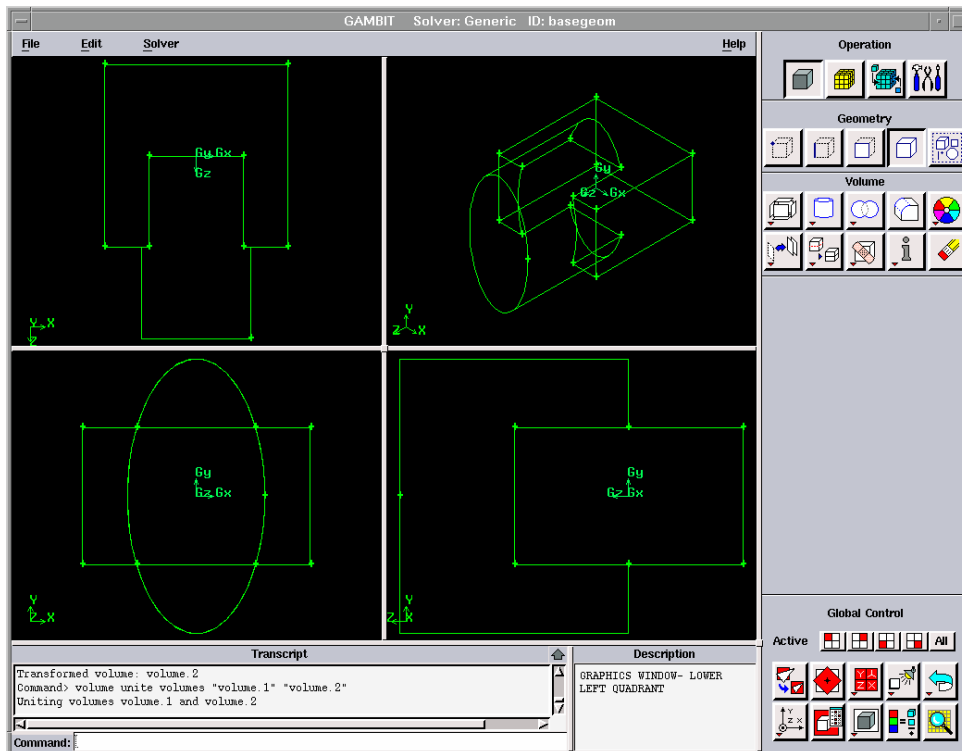



Figure 1-6: GAMBIT GUI—four graphics-window quadrants

6. Restore a single display of the model.
 - a) Use the left mouse button to select the graphics-window “sash anchor”—the small gray box in the center of the graphics window.
 - b) Use the mouse to drag the sash anchor to the bottom right corner of the graphics window.
7. Restore the front view of the model by left-clicking the **ORIENT MODEL**  command button in the **Global Control** toolpad.
8. Scale the model to fit the graphics window by clicking the **FIT TO WINDOW**  command button in the **Global Control** toolpad.

Step 5: Mesh the Volume

1. Create a mesh for the volume.



This command sequence opens the **Mesh Volumes** form.

Mesh Volumes	
Volumes	volume.1
Scheme:	<input checked="" type="checkbox"/> Apply <input type="checkbox"/> Default
Elements:	Hex/Wedge
Type:	Cooper
Sources	face.1
Spacing:	<input checked="" type="checkbox"/> Apply <input type="checkbox"/> Default
	1 <input type="text"/> Interval size
Options:	<input checked="" type="checkbox"/> Mesh
	<input type="checkbox"/> Remove old mesh
	<input type="checkbox"/> Remove lower mesh
	<input type="checkbox"/> Ignore size functions
<input type="button" value="Apply"/> <input type="button" value="Reset"/> <input type="button" value="Close"/>	

- a) *Shift*-left-click the volume in the graphics window.

GAMBIT will automatically choose the Cooper **Scheme Type** as the meshing tool to be used, and will use an **Interval size** of 1 (the default) under **Spacing**. See the GAMBIT Modeling Guide, Chapter 3 for details about the Cooper meshing tool.

- b) Click **Apply** at the bottom of the **Mesh Volumes** form.

*This accepts the volume you selected as the one to be meshed. It also accepts the source faces (the faces whose surface meshes are to be swept through the volume to form volume elements) that GAMBIT has chosen for the Cooper meshing scheme and starts the meshing operation based on the current **Mesh Volumes** form specifications. A status bar appears at the top of the GAMBIT GUI to indicate how much of the meshing is complete.*

The volume will be meshed as shown in Figure 1-7.

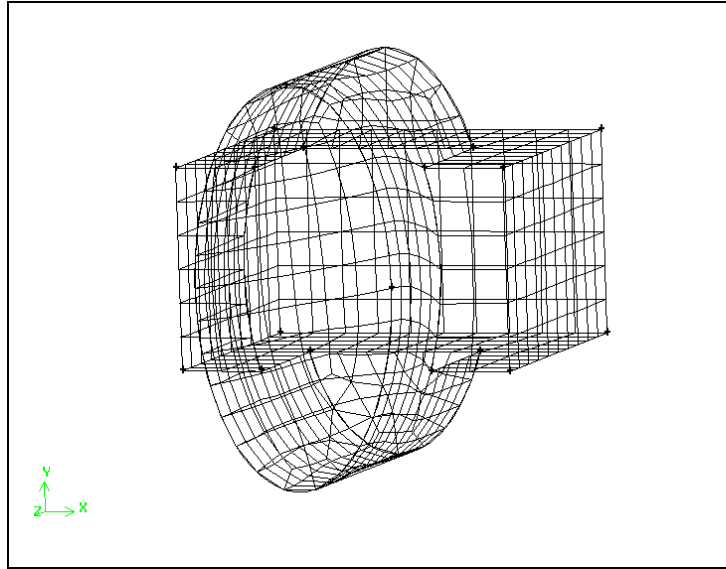



Figure 1-7: Meshed volume

Step 6: Examine the Mesh

It is important that you check the quality of the resulting mesh, because properties such as skewness can greatly affect the accuracy and robustness of the CFD solution. GAMBIT provides several quality measures (sometimes called “metrics”) with which you can assess the quality of your mesh. In the case of skewness measures such as EquiAngle Skew and EquiSize Skew, for example, smaller values are more desirable. It is also important to verify that all of the elements in your mesh have positive area/volume. You should consult the documentation for the target CFD solver for additional mesh quality guidelines.

1. Select the **EXAMINE MESH**  command button at the bottom right of the **Global Control** toolpad.

*This action opens the **Examine Mesh** form.*

Examine Mesh

Display Type:
 Plane Sphere Range

3D Element

Quality Type:
 EquiSize Skew

Display Mode:

Windows

Wire Faceted

Faceting Type:
 Quality Shade Hidden

Quality Histogram:
 Total Elements: 1150
 Active Elements: 135 (11.74%)
 Show worst element

Lower: 0.3

Upper: 0.4

0 1

- a) Click **Update** at the bottom of the **Examine Mesh** form.

GAMBIT does not automatically update the graphics display when you open the **Examine Mesh** form or modify its specifications, such as **Display Type** or **Quality Type**. To update the graphics display, you must click the **Update** pushbutton located at the bottom of the form. GAMBIT displays the **Update** pushbutton label in red lettering whenever the display needs to be updated to reflect the current **Examine Mesh** specifications.

Some **Examine Mesh** operations automatically update the graphics display. For example, if you select the **Display Type:Range** option and click one of the histogram bars (see below), GAMBIT automatically updates the display.

- b) Select Range under **Display Type** at the top of the **Examine Mesh** form.

*A histogram appears at the bottom of the form. The histogram consists of a bar chart representing the statistical distribution of mesh elements with respect to the specified **Quality Type**. Each vertical bar on the histogram corresponds to a unique set of upper and lower quality limits.*

The 3D Element type selected by default at the top of the form is a brick



- c) Select or retain EquiSize Skew from the **Quality Type** option menu.
- d) Click on one of the green vertical bars in the histogram to view elements within a certain quality range.

Each element has a value of skewness between 0 and 1, where 0 represents an ideal element. The histogram is divided into 10 bars; each bar represents a 0.1 increment in the skewness value. For a good mesh, the bars on the left of the histogram will be large and those on the right will be small.

Figure 1-8 shows the view in the graphics window if you click on the fourth bar from the left on the histogram (representing cells with a skewness value between 0.3 and 0.4).

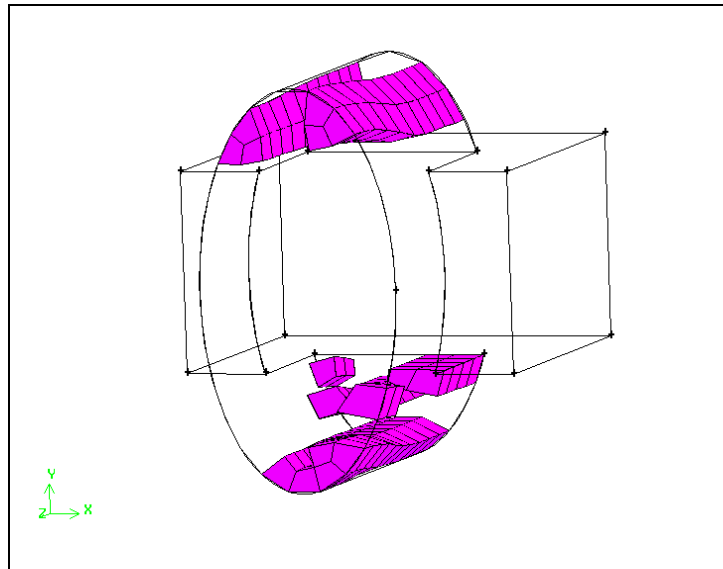

Figure 1-8: Elements of the mesh within a specified quality range

- e) Move the **Upper** and **Lower** slider boxes beneath the histogram to redefine the quality range to be displayed.

Step 7: Save the Session and Exit GAMBIT

1. Save the GAMBIT session and exit GAMBIT.

File → **Exit**

GAMBIT will ask you whether you wish to save the current session before you exit.

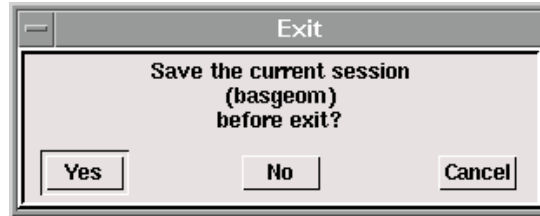

Click **Yes** to save the current session and exit GAMBIT.

1.5 Summary

This tutorial provided a quick introduction to GAMBIT by demonstrating how to create a simple 3-D geometry using the “top-down” modeling approach. The Cooper scheme was used to automatically generate an unstructured, hexahedral mesh. For more information on the Cooper scheme, consult the GAMBIT Modeling Guide.