

## **BEHAVIOR OF CONCRETE ROUND DOUBLE BEAM FRACTURE TOUGHNESS TEST SPECIMENS**

J.H. Hanson and A.R. Ingraffea,  
Department of Civil and Environmental Engineering, Cornell University,  
Ithaca, New York, USA

### **Abstract**

Laboratory fracture toughness tests of concrete using wedge-loaded round double beam specimens with a length to diameter ratio of 2:1 show two distinctly different specimen behaviors. Either the crack remains in the plane of the notch, and a valid test result can be obtained, or there is lateral cracking around mid-length which invalidates the results. Results of a controlled study show that the behavior transitions from desired to lateral cracking as the maximum aggregate size in a particular concrete increases. Two theories are proposed to explain this behavior and transition: new crack branching and crack turning. To prevent the lateral cracking behavior, two alternate testing techniques have been developed for use with the RDB specimen.

Key words: Fracture toughness testing, round double beam specimen, crack turning, specimen behavior, unreinforced concrete

### **1 Introduction**

The round double beam, RDB, (formerly called short rod) specimen (Fig. 1) and associated test methods are the basis of published standards for measuring the plane strain fracture toughness,  $K_{Ic}$ , of aluminum (ASTM E1304), cemented carbides (ASTM B771) and rock (ISRM, 1988). This specimen has many advantages for measuring the fracture toughness of concrete including the ability

to obtain  $K_{Ic}$  from specimens too small for linear elastic fracture mechanics conditions. The cylindrical shaped specimen may be cut from core samples for existing structures or cast for new structures.

To obtain a valid fracture toughness test, both the material and specimen behaviors must be valid. Valid material behavior means that the test produces a specimen-size-independent  $K_{Ic}$ . Valid specimen behavior means that the crack follows the same path as the one assumed in its calibration. This paper focuses on the specimen behavior issues of RDB test specimens.

Laboratory test results show that concrete RDB specimens with a length to diameter ratio of approximately 2:1 exhibit one of two specimen behaviors. Either the crack follows the desired path through the entire chevron notch, or a lateral crack develops near mid-length (Fig. 2). Results from tests on RDB specimens with three different maximum aggregate sizes are presented. As the maximum aggregate size increased, the specimen behavior transitioned from desired to lateral cracking.

Two theories can explain the lateral cracking behavior and the transition from desired cracking behavior. The first is new crack formation. The tensile capacity of the concrete is exceeded, and a new crack branches off in the lateral direction. The second is that the crack turns. Both theories are based on the presence of a tensile stress adjacent to the crack in the direction of the desired crack propagation. This tensile stress is called a positive T-stress (Cotterell and Rice, 1980).

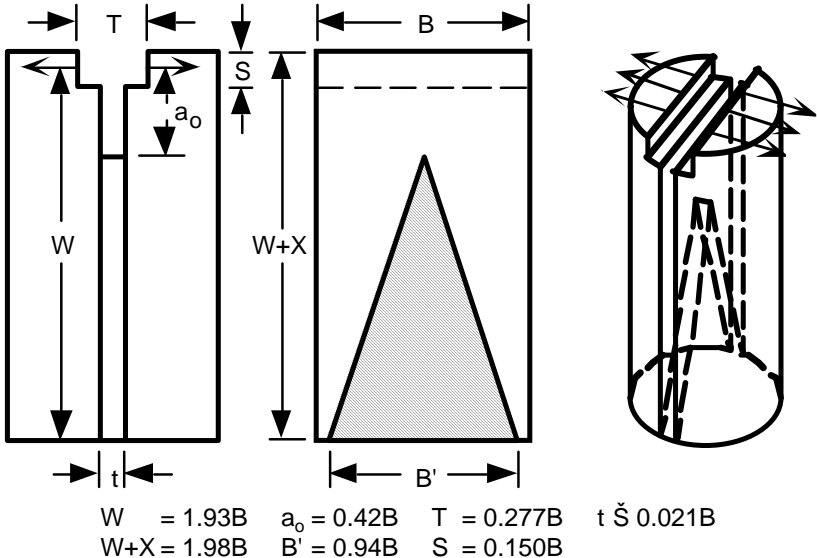

Fig. 1. Round double beam specimen with applied load, nomenclature and normalized dimensions

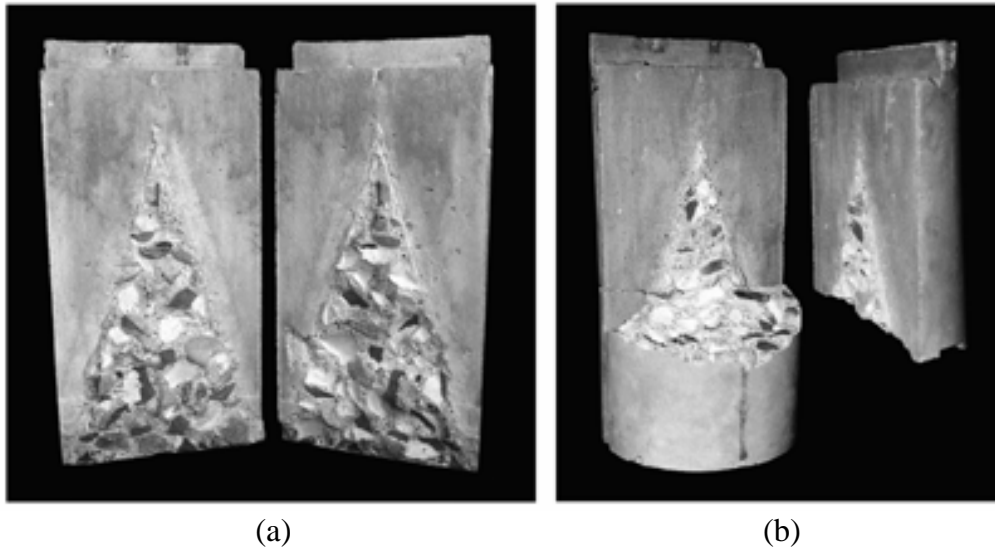

Fig. 2. Types of behavior: (a) desired cracking and (b) lateral cracking

To reduce or eliminate the positive T-stress, two alternative loading techniques have been developed. The first is to precompress the specimen. The second is to load the specimen in compression. Both techniques have proven successful. Each alternative has unique advantages and disadvantages.

## 2 Round double beam

### 2.1 Geometry and typical testing techniques

The round double beam is a cylindrical fracture toughness test specimen with a chevron notch (Fig. 1). Standard geometries typically have a length,  $W$ , to diameter,  $B$ , ratio of 1.45:1 or 2:1. The normalized dimensions of the specimens used in this investigation are shown in Figure 1. The standard RDB dimensions (ASTM E1304) were modified in this study to facilitate casting the notch into standard concrete test cylinders (152 mm x 305 mm).

The groove characterized by width,  $T$ , and depth,  $S$ , is used in some testing techniques to allow application of the prying load as shown. This prying load may be applied by many different techniques. Barker (1978) developed the “Fractometer”<sup>®</sup> which uses a thin, pressurized bladder that applies an area load over the notch face. Catalano (1983), Santos (1998) and others have applied point loads at the top of the specimen directly above the tip of the notch. A technique used in this investigation is wedge loading (Fig. 3) with a wedge angle,  $\alpha$ , of  $5^\circ$ . The wedge loading, friction reducing device was developed by Tschegg (1991, 1993).

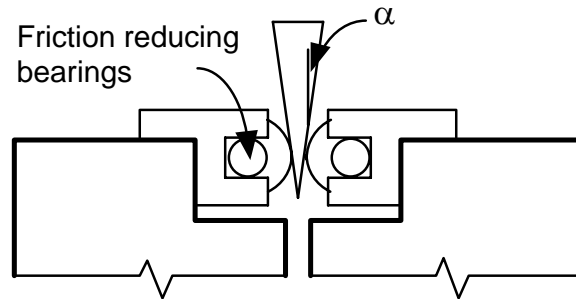

Fig. 3. Wedge loading device on specimen

The presence of the chevron notch allows stable crack propagation in load control up to the critical crack length. Beyond that point, the crack propagates unstably in load control. Barker (1977) showed that under linear elastic fracture mechanics, LEFM, conditions the critical crack length is material independent. Therefore, the fracture toughness can be determined by measuring the peak load only. This type of testing is often referred to as Level I.

For specimens that are too small to exhibit LEFM conditions, Barker (1979) developed a compliance based technique for determining the fracture toughness. This technique requires recording the load versus crack mouth opening displacement, CMOD, graph with at least two unload-reload cycles. This type of testing is often referred to as Level II.

## 2.2 Advantages

Many of the appealing qualities of the RDB specimen and typical testing techniques have been discussed by Hanson and Ingraffea (1997). These advantages include a natural crack at the critical crack length without requiring precracking. In addition, the RDB specimen has a relatively large region for process zone growth compared to its total volume. Harmuth (1995) has shown that crack propagation in a wedge loaded cube with a straight through crack is stable in displacement control. The laboratory tests conducted in this investigation indicate that the same is true for RDB specimens with a length to diameter ratio of approximately 2:1 and a wedge angle,  $\alpha$ , of  $5^\circ$ . Therefore, non-servo controlled test machines may be used if the wedge displacement can be controlled.

## 3 Laboratory investigation

### 3.1 Types of behavior

Preliminary tests of wedge loaded, concrete RDB specimens produced two distinct specimen behaviors. The desired behavior is cracking that remains in the notch plane (Fig. 2a). Therefore, the geometry calibration factor for the RDB specimen in Mode I loading is valid. The undesirable behavior is lateral cracking (Fig. 2b). Due to the changes in geometry and mode of loading, the geome-

try calibration factor is no longer valid. A lateral crack may develop in one or both sides of the specimen.

### 3.2 Investigation details

To help understand the cause of the lateral cracking specimen behavior, a behavior study was conducted. RDB specimens made from three different mixes were tested. All three concrete mixes had the same water-cement ratio (0.40), used the same sand, and were tested at the same age (36 days). Only the maximum size and quantity of the coarse aggregate was changed. For comparison, we cast single edge notched beams according to RILEM (1990) recommendations. Strength measurements were made using two to three replicate splitting tension tests according to ASTM C496-96. All specimens were cured under similar conditions.

The results of the behavior study are shown in Table 1. Results from the preliminary tests are also presented. As expected, the beams exhibited valid specimen behavior. Toughness results for the beams have not been included; comparison of beam and RDB results will be published elsewhere. As the maximum aggregate size increased, the RDB specimen behavior transitioned from desired cracking to lateral cracking. For this particular mix, the transition appeared to occur when the coarse aggregate reached approximately 13 mm.

Table 1. Test results

	Behavior Study			Preliminary Tests		
Max. Aggregate Size (mm)	1	13	25	25	25	25
Water-Cement Ratio	0.40	0.40	0.40	0.31	0.58	0.40
Diameter, B (mm)	152	152	152	152	304	607
RDB $\frac{\# \text{ valid}}{\# \text{ tested}}$	5/5	3/5	1/10	0/5	0/2	0/1
RILEM $\frac{\# \text{ valid}}{\# \text{ tested}}$	3/3	2/2	1/1	A	A	A
Avg.	1.37	1.84	1.48	A	A	A
$K_Q$ (MPa $\sqrt{\text{m}})^B$ Max.	1.52	2.09	1.48	A	A	A
Min.	1.16	1.67	1.48	A	A	A
Tensile Strength (MPa)	3.62	3.13	3.32	5.06	A	A

A. No data available.

B. Level I toughness from RDB specimens with valid behavior;  $Y_{\min}^* = 48.3$ .

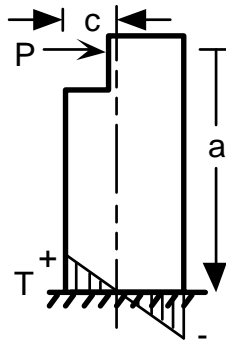

Fig. 4. Approximation of specimen half as a cantilever

## 4 Lateral cracking

### 4.1 Positive T-stress

The prying load near the top of the specimen generates a tensile stress component parallel to the crack propagation direction. Within the fracture mechanics community, this component is called a positive T-stress. An approximate value of this T-stress may be obtained by considering half of the RDB specimen as a cantilever loaded at the end and fixed at the base (Fig. 4). Under LEFM conditions with a flat R-curve material, the Mode I stress intensity factor,  $K_I$ , equals the plane strain fracture toughness,  $K_{Ic}$ , at all crack front levels in the RDB specimen. Therefore, the prying load,  $P$ , is given by the relation (Newman, 1984)

$$P = \frac{K_{Ic} B \sqrt{W}}{Y^*(a)}, \quad (1)$$

where  $B$  and  $W$  are as shown in Figure 1, and  $Y^*(a)$  is the normalized stress intensity factor which is a function of the crack length,  $a$ . The prying force creates a moment at the crack front equal to the prying load,  $P$ , times the crack length,  $a$ . Immediately adjacent to the crack, the T-stress,  $T$ , is given approximately by Equation 2 where  $c$  is the distance from the neutral axis to the crack face and  $I$  is the moment of inertia of a half circle,

$$T = \frac{Pac}{I} = \frac{K_{Ic} B \sqrt{W} ca}{I Y^*(a)}. \quad (2)$$

The presence of a positive T-stress near the crack front leads to two potential explanations of the lateral cracking behavior: new crack branching and crack turning. Either or both might be the cause of the observed lateral cracking.

#### 4.2 First hypothesis: new crack branching

If the tensile T-stress exceeds the tensile capacity of the concrete, a new crack may branch off in one or both lateral directions. Once the new crack has initiated, it will be easier for that crack to propagate rather than the original crack continuing in the notch.

This theory is supported by several observations in some of the tested specimens. The presence of lateral cracks on both sides of the notch plane in several of the specimens suggests that new cracks formed rather than the original crack turning. In the single 607 mm specimen, the desired crack can be seen continuing in the notch plane for several centimeters beyond the lateral crack. By making the simplifying, albeit incorrect, assumption that the 152 mm diameter concrete specimens were behaving under LEFM conditions, we can use Equation 2 to predict the crack length where T exceeds the average splitting tensile strength. For these calculations, the Level I toughness,  $K_Q$ , is used in place of  $K_{Ic}$ . The predicted lengths are shown in Table 2. The calculated T-stress did not exceed the measured tensile strength of the 1 mm concrete; therefore, those results have been omitted from the table. The other predicted lengths are shorter than the observed initiation lengths which supports the theory that T is exceeding the tensile capacity. Note that the predicted lengths may be systematically short if the measured peak load was increased by the presence of the lateral crack.

#### 4.3 Second hypothesis: crack turning

The other hypothesis is that the desired crack turns. Cotterell and Rice (1980) showed that the second term in the Irwin-Williams series expansion of the crack tip field has a significant influence on crack path stability under Mode I loading. They labeled this term T. They showed that when  $T < 0$ , the crack path is stable. When  $T > 0$ , the crack path is unstable, and the crack tends to turn if perturbed from its original path.

Table 2. Predicted and observed lateral crack initiation lengths

Max. Aggregate Size (mm)		13	25	25
Water-Cement Ratio		0.40	0.40	0.31
Diameter, B (mm)		152	152	152
Predicted/Actual (mm/mm)	Avg.	114/152	118/179	126/174
	Max.	116/169	156/236	143/200
	Min.	111/141	92/120	113/144

The tendency of positive T-stress specimens to turn is well known for the double cantilever beam, DCB, specimen. In order to retard that behavior, Berry (1963) added grooves along the outer edges of the desired crack path in a DCB specimen. As the crack tries to turn out of the groove, there is more material to resist it. If the increase in resistance is large enough, the crack remains in the groove. If the groove is not deep enough, or if the positive T-stress is large enough, the thicker material is not sufficient to divert the crack back into the groove, and the crack continues to turn. The chevron notch of the RDB specimen serves the same function as the grooves added by Berry to the DCB specimen.

Positive T-stress alone, however, does not explain the behavior transition observed in the study results. Cotterell and Rice (1980) also showed that the path of the turning crack depends on the ratio  $T/K_I$  and the initial perturbation angle,  $\theta_0$ . As either or both of these quantities are increased, the crack will turn more sharply. Under LEFM conditions in the RDB specimen, the ratio of  $T/K_I$  depends only upon the geometry of the specimen and the crack length,

$$\frac{T}{K_I} = \frac{B\sqrt{W}ca}{IY^*(a)} . \quad (3)$$

Therefore, only the initial perturbation angle,  $\theta_0$ , can change from mix to mix. A larger maximum aggregate size will likely produce larger initial perturbations which will cause the crack to turn more sharply. If it could be shown that a crack turning more sharply is more likely to continue propagating out of the grooves, this hypothesis would be further supported by the results of the behavior study. Such a proof was not undertaken by the authors.

## 5 Alternatives for eliminating lateral cracking

### 5.1 Precompression

One method of reducing the positive T-stress field along the crack front is to precompress the specimen. This technique was used by Ingraffea et al. (1984) to successfully suppress lateral cracking in rock RDB specimens with length to diameter ratios of 1.5:1. The arrangement used in this study is shown in Figure 5a. The four rods were prestressed before testing to approximately 3650 N which corresponds to a compressive stress of approximately 0.80 MPa over the cross section of the RDB specimen. During testing, the load in any one rod changed by less than  $\pm 3\%$ . Two specimens of 152 mm diameter and 0.40 water cement ratio concrete were tested using this technique. The maximum aggregate size in the concrete was 25 mm. Both specimens exhibited only desired cracking behavior. An in-depth study was not performed to determine the

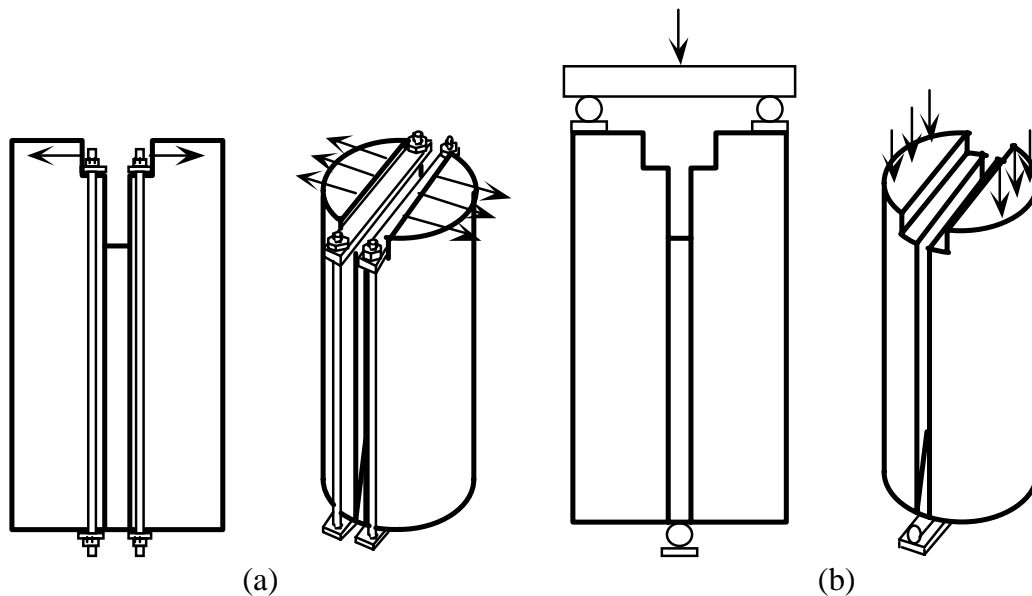

Fig. 5. Alternatives: (a) precompression apparatus on RDB specimen and (b) compression loading of RDB specimen

minimum prestress required, although it might be much less than the amount used.

The precompression alternative has several apparent advantages. Because the specimen is still tested by wedge loading, the test is stable in displacement control. Therefore, a non-servo controlled testing machine may be used. Also, the mechanical advantage of the wedge results in machine applied loads typically less than 1 kN for a 152 mm diameter, concrete specimen.

There are several disadvantages to this technique as well. The geometry calibration,  $Y^*$ , depends on the amount of prestress applied. New calibrations must be determined for each prestress level used. Different concrete mixes will likely have different minimum prestress requirements. In addition, the bars must be instrumented in order to know the prestress level. This requires four additional measurements during testing.

## 5.2 Compression loading

Another alternative is to change the loading from prying to eccentric compression loading. Since the loads are applied outside the neutral axis of the specimen halves (Fig. 5b), they generate an opening moment. The opening moment generates a positive T-stress similar to the wedge loading. However, the applied compressive loads also generate a compressive stress through the specimen down to the support. That compressive field reduces the magnitude of the positive T-stress field along the notch face. Six specimens of 152 mm diameter with 25 mm aggregate and water cement ratios from 0.24 to 0.58 have been tested using this technique. A 152 mm specimen with 1 mm aggregate and a

water cement ratio of 0.40 has also been tested. All of the specimens exhibited desired cracking behavior only.

The compression loading technique has several advantages. Only a stiff beam and three rollers are required to load the specimen. By comparison, the wedge loading technique requires special friction reducing equipment that can be costly to purchase or fabricate and difficult to maintain.

Compression loading has disadvantages also. Laboratory tests confirm that the compression loading technique is not stable in displacement control. It is stable in CMOD control, but such testing requires a servo controlled test machine. To perform a Level II analysis, vertical displacement under the applied loads must be measured. This requires at least two, preferably four, more measurements compared to a Level I test.

## **6 Conclusions**

Use of the wedge loaded round double beam specimen with a length to diameter ratio of approximately 2:1 for measuring the fracture toughness of concrete produces two distinct specimen behaviors: desired cracking and lateral cracking. Lateral cracking is caused by a positive T-stress and renders the test invalid.

Results of a laboratory study show that for a given mixture of concrete, as the maximum aggregate size increases, the tendency for lateral cracking also increases. These results are supported by two theories about the cause of lateral cracking behavior. The first theory is that the T-stress exceeds the tensile capacity of the concrete, and a new crack branches. The second theory is that the desired crack turns. Under certain conditions, the crack can not be contained in the desired plane by the notch grooves. Once the crack propagates out of the notch, the positive T-stress continues to turn the crack away from the original path. Both theories may be causing the observed lateral cracking behavior.

To control the behavior, two alternatives have been successfully developed. One is to precompress the specimen before wedge loading. The second is to apply a pair of eccentric, compressive loads to the top of the specimen. Both techniques exhibit desired cracking behavior only, and each technique has unique advantages and disadvantages.

## **7 Acknowledgments**

Funding for this research was provided by the National Science Foundation, Project #CMS-9414243. The authors would like to thank Professor Alan T. Zehnder, Cornell University, for his insight in developing the compression loading technique.

## 8 References

- American Society for Testing and Materials (1987) Standard test method for short rod fracture toughness of cemented carbides (B771-87), **Annual Book of ASTM Standards**, Vol. 02.05, Philadelphia, PA.
- American Society for Testing and Materials (1996) Standard test method for splitting tensile strength of cylindrical concrete specimens (C496-96), **Annual Book of ASTM Standards**, Vol. 04.02, Philadelphia, PA, 262-265.
- American Society for Testing and Materials (1997) Standard test method for plane-strain (chevron-notched) fracture toughness of metallic materials (E1304-97), **Annual Book of ASTM Standards**, Vol. 03.01, Philadelphia, PA, 838-848.
- Barker, L.M. (1977) A simplified method for measuring plane strain fracture toughness, **Engineering Fracture Mechanics**, 9, 2, 361-369.
- Barker, L.M. (1978) Short rod  $K_{Ic}$  measurements of  $Al_2O_3$ , in **Fracture Mechanics of Ceramics**, (eds R.C. Bradt, D.P.H. Hasselman, and F.F. Lange), 3, New York, NY, 483-494.
- Barker, L.M. (1979) Theory for determining  $K_{Ic}$  from small, non-LEFM specimens, supported by experiments on aluminum, **International Journal of Fracture**, 15, 6, 515-536.
- Berry, J.P. (1963) Determination of fracture surface energies by the cleavage technique, **Journal of Applied Physics**, 34, 1, 62-68.
- Catalano, D.M. (1983) Concrete Fracture: A linear elastic fracture mechanics approach, **M. Sc. Dissertation**, Department of Civil and Environmental Engineering, Cornell University, Ithaca, NY.
- Cotterell, B. and Rice, J.R. (1980) Slightly curved or kinked cracks, **International Journal of Fracture**, 16, 2, 155-169.
- Hanson, J.H. and Ingraffea, A.R. (1997) Standards for fracture toughness testing of rock and manufactured ceramics: what can we learn for concrete?, **Cement, Concrete, and Aggregates**, CCAGDP, 19, 2, 103-111.

- Harmuth, H. (1995) Stability of crack propagation associated with fracture energy determined by wedge splitting specimen, **Theoretical and Applied Fracture Mechanics**, 23, 103-108.
- Ingraffea, A.R., Gunsallus, K.L., Beech, J.F. and Nelson, P.P. (1984) A short-rod based system for fracture toughness testing of rock, in **Chevron-Notched Specimens: Testing and Stress Analysis**, ASTM STP 855, (eds J.H. Underwood, S.W. Freiman, and F.I. Baratta), Philadelphia, PA, 152-166.
- International Society for Rock Mechanics (1988) Suggested methods for determining the fracture toughness of rock, **International Journal of Rock Mechanics and Mining Sciences & Geomechanics Abstracts**, 25, 2, 71-96.
- Newman, J.C., Jr. (1984) A review of chevron-notched fracture specimens, in **Chevron-Notched Specimens: Testing and Stress Analysis**, ASTM STP 855, (eds J.H. Underwood, S.W. Freiman, and F.I. Baratta), Philadelphia, PA, 5-31.
- RILEM (1990) Determination of fracture parameters ( $K_{Ic}^S$  and  $CTOD_c$ ) of plain concrete using three-point bend tests," **Materials and Structures**, 23, 457-460.
- Santos, A.C. (1998) Determinação da Tenacidade ao Fraturamento de Concretos Utilizando Corpos de Prova do Tipo Short-Rod, **M. Sc. Dissertation**, Universidade Estadual de Campinas, Campinas, SP, Brazil, (in Portuguese).
- Tschegg, E.K. (1991) New equipments for fracture tests on concrete, **Materialprufung/Materials Testing**, 33, 338-342.
- Tschegg, E.K. (1993) Lasteinleitungsrichtung, Austrian Patent AT 396997 B, 15 May (in German).