

Name _____ Section _____

ES205
Examination I
March 25, 2008

Problem	Score
1	/25
2	/45
3 (short answer problems)	/30
Total	/100

Show all work for credit

AND

Turn in your signed help sheet

AND

Stay in your seat until the class ends

(Translation: I am not going to let you leave early, so you might as well check your answers!)

The circuit shown is called a “Inductance Simulator”. Determine the equations necessary to find the differential equation relating the input i_{in} and the output v_1 (measured with respect to ground). Be sure to clearly label all your variables on the circuit diagram. **DO NOT SOLVE THE EQUATIONS** but clearly number you equations and list your unknowns. Assume all the resistances and the capacitance are known.

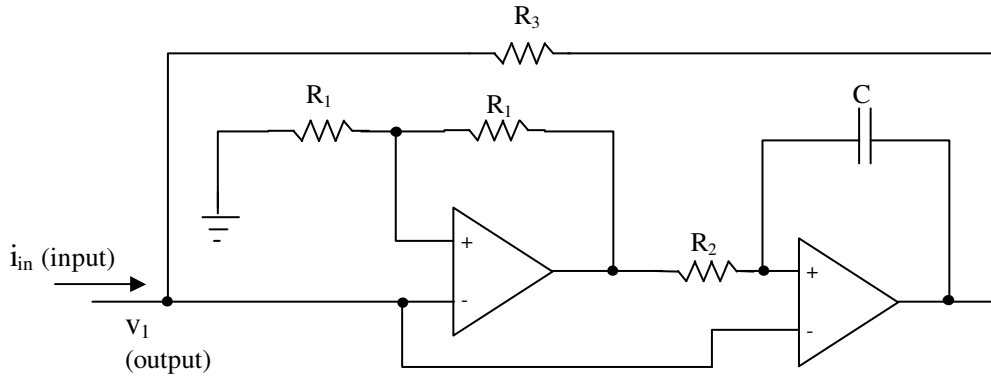

Unknowns

3.1 (cont.) The differential equation for a system is given by $\ddot{x} + \dot{x} + 4x = 4y + \dot{y}$.

f) Draw a simulation block diagram only using gains, integrators and sum blocks. (4 pts)

3.2 The rod shown below is subjected to a longitudinal force (along the axis of the rod – NOT torsion). To increase the damping of the rod, an annulus containing oil is placed around it (the end caps have been removed in the picture below). Assume all the dimensions and parameters are given.

a) What is the rod's stiffness? (4 pts)

b) What is the damping added to the system due to the annulus? (2 pts)

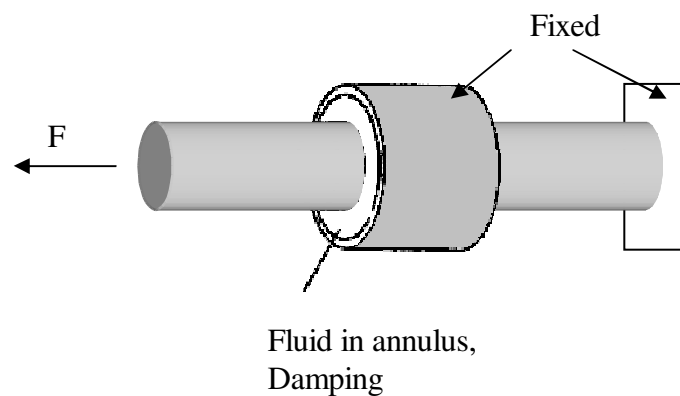

3.3 A portion of the step response of a second order system is shown below along with the cursor values you would obtain from Matlab. The steady state value is 10 mm. Show me how you would determine:

- a) The damping ratio of the system (3 pts)
- b) The natural frequency of the system (3 points)

DO NOT DO ANY CALCULATIONS. Just show me the equations you would use and what numbers you would substitute in.

