

Name _____ Section _____

ES205
Examination I
March 31, 2005

Problem	Score
1	/30
2	/30
3	/40
Total	/100

Show all work for credit
AND
Turn in your signed help sheet
AND
Stay in your seat until the class ends
(Translation: I am not going to let you leave early,
so you might as well check your answers!)

You must show all work for full credit on these problems.

- 1.1 The differential equation for a system is given by $4\ddot{x} + 32\dot{x} + 400x = 20y$. Determine
- the damping ratio of the system.
 - the natural frequency of the system
 - define state variables and write in state space

d) An input $y = 2$ was applied to this system and the plot below was obtained. Unfortunately the labels did not print. Please fill in the two boxes with the appropriate values.

Output from scope:

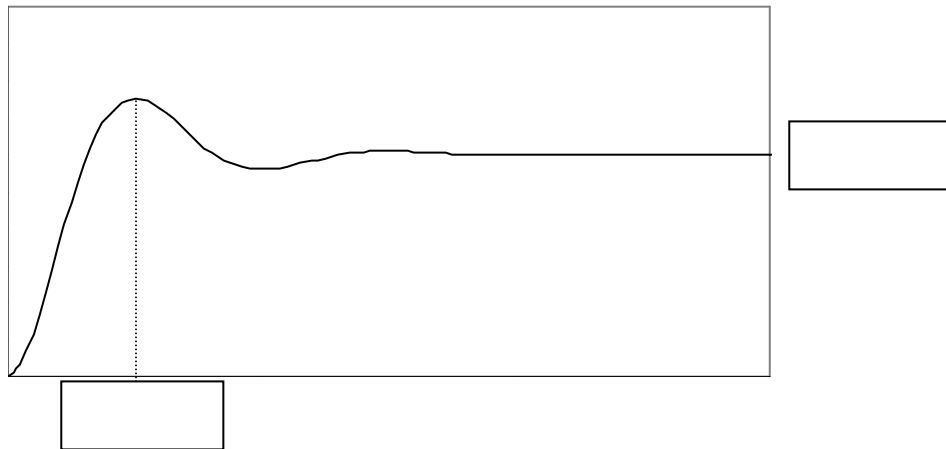

1.2 A first order system is represented by the following equation: $\dot{x} + 32x = 64f(t)$
 What is the time constant of the system?

1.3 What differential equation is modeled by the block diagram shown below. The input is F and the output is y .

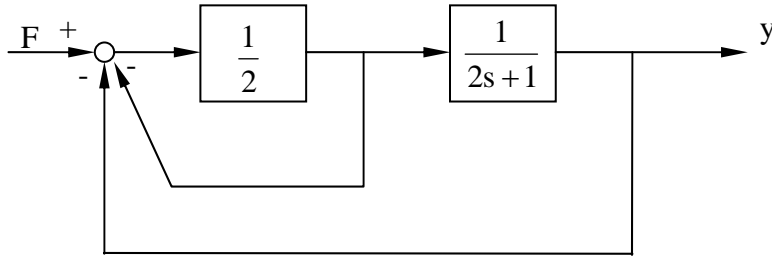

1.4-1.5) The cantilever beam shown below has length, L , elastic modulus, E , a mass, m_1 , and a mass moment of inertia, I . A spring of stiffness, k , is located at the end of the beam. The spring supports a mass, m_2 . Note: x is measured from the static equilibrium point.

(1.4) Replace the beam and spring with an equivalent spring system as shown.

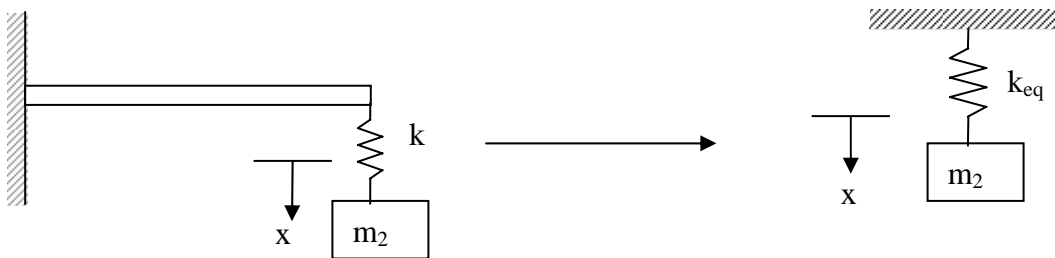

$k_{eq} = \underline{\hspace{2cm}}$

(1.5) What assumption must you make in order to determine k_{eq} ?

Name _____
ES205 Examination I

Problem 2

30 pts
March 31, 2005

An ultralow offset high-speed inverter is shown below. Determine the equations necessary to find the differential equation relating the input v_i and the output v_o . Be sure to clearly label all your variables on the circuit diagram.

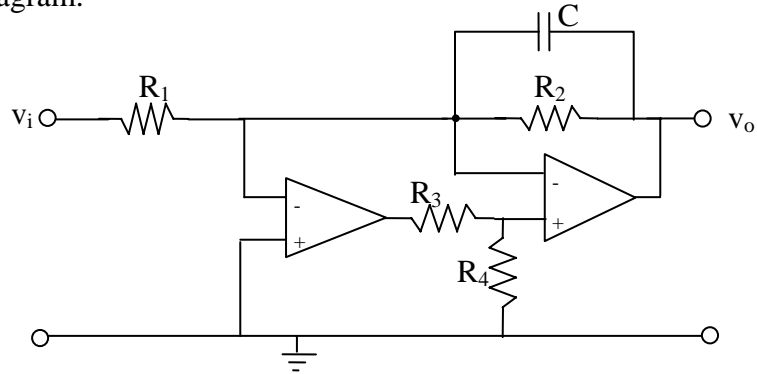

Unknowns

For system shown below determine the necessary equations to find the differential equation of motion (EOM) that relates the known input voltage, v_a , to the unknown output displacement, x_2 . Assume the output shaft of the motor is rigid. **Do not find the EOM but number the equations that you would use and generate a list of the unknown variables.**

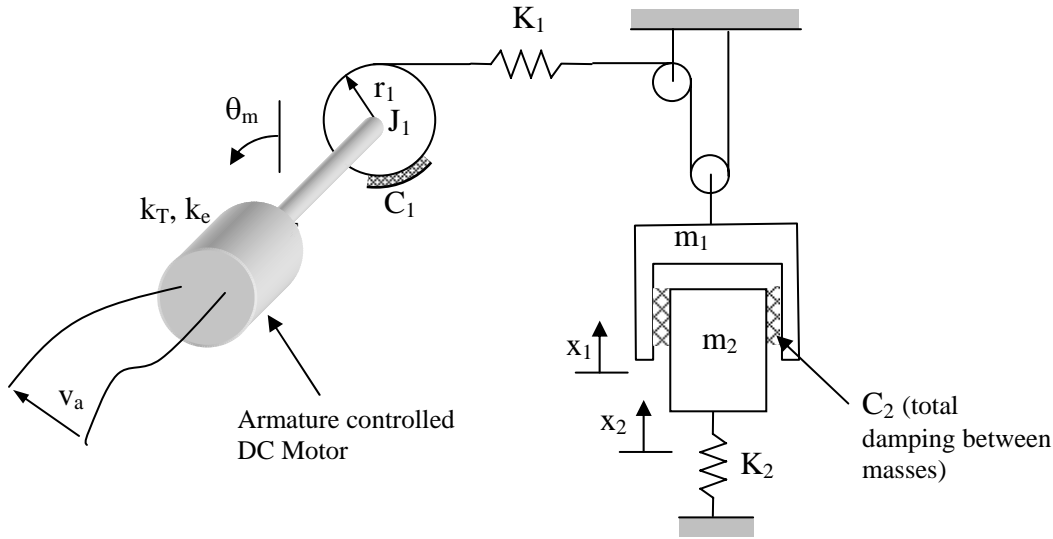

Unknowns