

Name \_\_\_\_\_ Section \_\_\_\_\_

**ES205**  
Examination II  
April 22, 2002

Problem	Score
1	/25
2	/40
3	/35
Total	/100

Show all work for credit  
AND  
Turn in your signed help sheet

**Problem 1.1 (5 pts)**

After a number of years of use, it is noted that to obtain a given flow rate, the head loss is increased to 1.6 times its value of the original smooth pipe. If the Reynolds number is  $10^6$ , determine the relative roughness of the pipe in its current state.

**Problem 1.2 (5 pts)**

A dynamic system is modeled by the block diagram shown below. Determine the transfer function relating the input  $F$  and the output is  $Y$ .

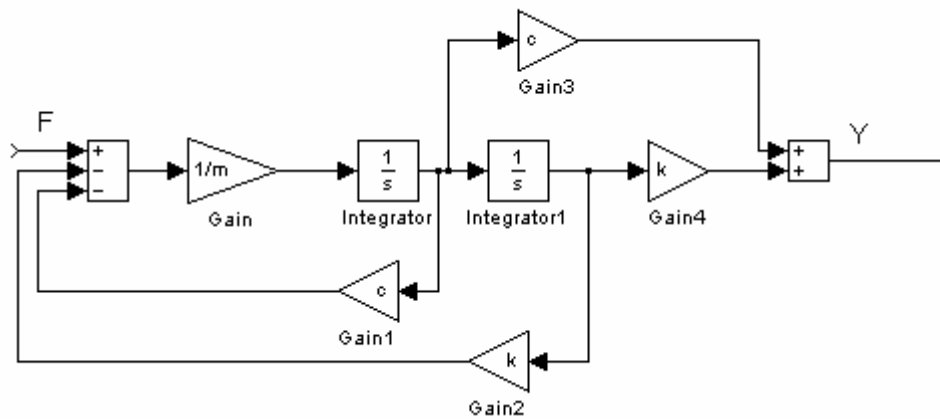

**Problem 1.3 (5 pts)** A system demand curve is shown in the figure below with seven different pump curves. At the system outlet, the minimum required head is 350 ft and the maximum allowable flow rate is 1100 gpm. Select the best **model** pump for this system. What is the resulting **flow rate**, and what is its **efficiency**?

Fill in the blanks: model \_\_\_\_\_ flow rate \_\_\_\_\_ efficiency \_\_\_\_\_

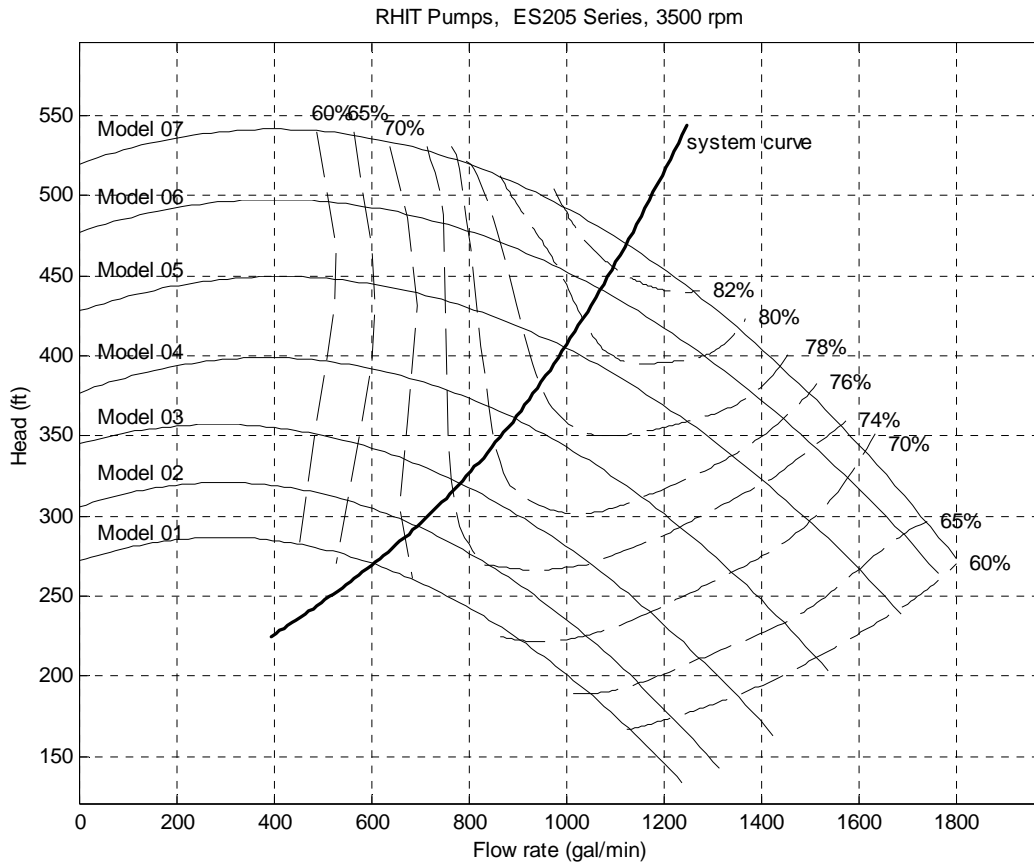

**Problem 1.4 (5 pts)**

**Problem 1.5 (5 pts)**

A valve-controlled hydraulic actuator is shown in the accompanying illustration. In this particular system the piston rod is fixed and the cylinder is free to move. The valve body is rigidly attached to the cylinder and moves with it. Obtain the differential equation, in which **x** is the input and **y** is the output

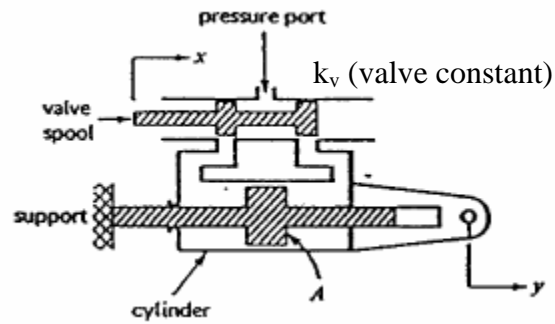

A cylindrical titanium rod initially at  $1800\text{ K}$  is dropped into a large bath of oil. The convection coefficient is  $h = 648.47\text{ W}/(\text{m}^2 \cdot \text{K})$  and the rod's emissivity is  $0.8$ . The bath, wall and air temperatures are assumed constant at  $300\text{ K}$ .

- Assuming that the rod length is constant at  $0.5\text{ m}$  and  $k$  for titanium is  $20.4\text{ W}/\text{m}\cdot\text{K}$ , determine the maximum rod diameter for the lumped parameter model to be valid.
- Determine the differential equation governing the rod temperature.
- Assuming that the rod has a surface area of  $A = 0.032\text{ m}^2$ , a mass of  $0.18\text{ kg}$ , the lumped capacitance assumption is not violated, and radiation heat transfer can be neglected, solve for the rod temperature as a function of time. The specific heat of titanium is  $c = 522\text{ J}/(\text{kg} \cdot \text{K})$ .
- How long will it take for the rod to reach a temperature of  $350\text{ K}$ ?

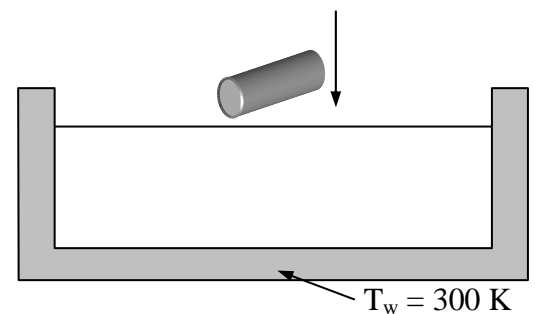

An armature-controlled DC motor drives a rack and pinion. The vertical movement of the rack opens and closes a valve, changing the flow rate into the open tank. Write the equations necessary to relate the height of the fluid in the tank to the voltage input. **DO NOT SOLVE THE EQUATIONS.** Your answer should consist of a **figure** (or figures) with clearly labeled variables, **numbered equations**, a list of **unknowns**, and a list of **system inputs**.

Assume the motor shaft is rigid. The moments of inertia of the rotor and pinion (small gear) are lumped together as  $J$ . The minor loss coefficient for the valve in the pipe,  $K$ , is a nonlinear function of the amount the valve is opened. The DC motor has parameters  $R_a$ ,  $L_a$ ,  $K_E$ , and  $K_T$ .

