

Name _____ Section _____

ES204
Examination III
February 11, 2000

Problem	Score
1	/30
2	/30
3	/40
Total	/100

Show all work for credit
AND
Turn in your signed help sheet
AND
Stay in your seat until the end of class

NOTE:
Set up all the equations first and save the solutions to the end (the actual numerical answers will only be worth 2 points).

Name _____

ES204 Examination III

Problem 1

30 pts

Feb. 11, 2000

Two smooth billiard balls A and B have an equal mass of $m = 0.2$ kg. If A strikes B with a velocity of $v_A = 2$ m/s as shown, determine their final velocities just after collision. Ball B is originally at rest and the coefficient of restitution is $e = 0.75$.

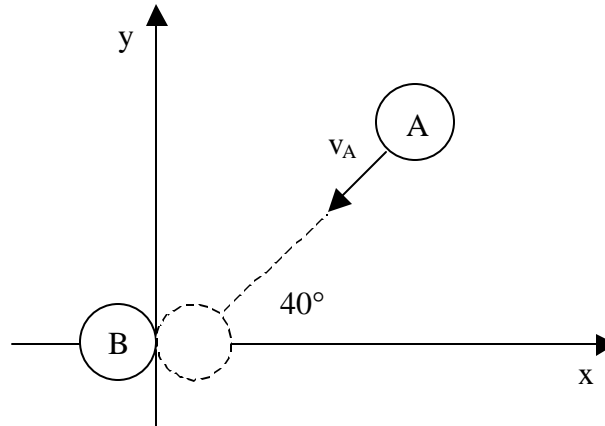

Name _____

ES204 Examination III

Problem 2

30 pts

Feb. 11, 2000

The angular velocity of crank AB is constant, 20.0 rad/s counterclockwise. Slider C must move on the x-axis. When the slider crank mechanism is in the position shown in the diagram, with AB perpendicular to the x-axis,

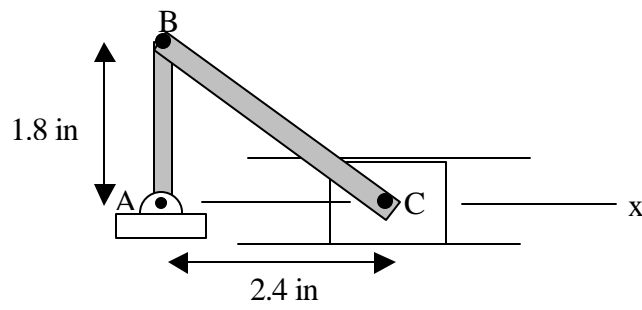

compute the following.

- The acceleration of Point C
- The angular acceleration of BC

Name _____
ES204 Examination III

Problem 3

40 pts
Feb. 11, 2000

A uniform slender bar AB of mass m_b is suspended as shown from a uniform disk of mass m_d . Assuming the disk rolls without slipping determine the equations necessary to determine the acceleration of point A and the angular acceleration of the bar. DO NOT SOLVE THE EQUATIONS. Your answer should consist of a set of numbered equations and a list of unknowns.

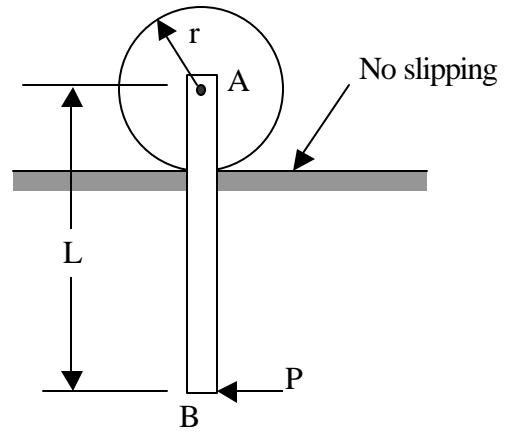

Unknowns
