

Name \_\_\_\_\_ Section \_\_\_\_\_

**ES204**  
Examination III  
February 12, 1999

Problem	Score
1	/30
2	/40
3	/30
Total	/100

Show all work for credit  
AND  
Turn in your signed help sheet  
AND  
Stay in your seat until the end of class

NOTE:  
Set up all the equations first and save the solutions to the end (the actual numerical answers will only be worth 2 points).

Name \_\_\_\_\_  
ES204 Examination III

**Problem 1**

30 pts  
Feb. 12, 1999

A stepped disk that weighs 40 lbf ( $m=1.24$  slugs) and has a mass moment of inertia of  $0.2 \text{ slug-ft}^2$  has a cable wrapped around it as shown. If it is released from rest, determine

- the initial acceleration of the center of gravity
- how long would it take to fall 3 ft?

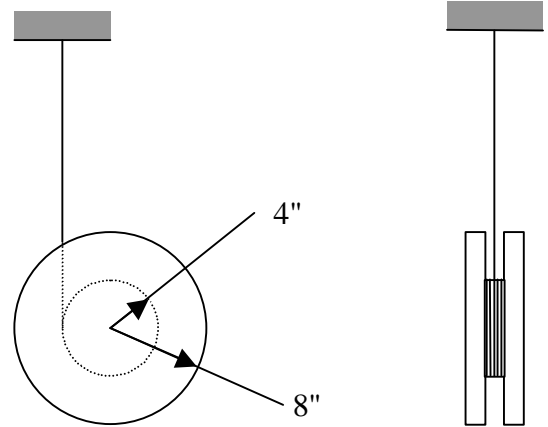

The long, slender, homogenous rod, AB, is pinned to a disk as shown. Pin joint B is aligned horizontally with the center of the disk G. The rod is released from rest causing the disk to roll without slipping. At the instant shown  $\omega = 2 \text{ rad/s}$  (CCW) and the acceleration of point G is found to be  $3.27 \text{ ft/s}^2$  to the left.

Find:

- a) the angular acceleration of the disk
- b) the acceleration of point B

If the disk has a mass of 2 slugs and mass moment of inertia of  $1 \text{ slug-ft}^2$  and the friction force is 10.6 lbf to the left at this instant determine:

- c) the reaction at point B

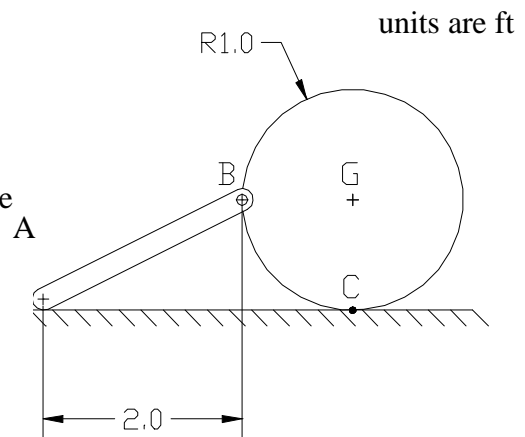

Name \_\_\_\_\_  
ES204 Examination III

**Problem 3**

30 pts  
Feb. 12, 1998

A slender uniform bar is dropped onto a fixed wedge so that its velocity of impact is 4 m/s. The bar has a mass of 2 kg and length 1 m ( $I_G = 0.167 \text{ kg}\cdot\text{m}^2$ ). The coefficient of restitution between the bar and the wedge is 0.7 and the friction between the two is negligible. Determine the angular velocity of the bar after impact.

