

Name \_\_\_\_\_ Section \_\_\_\_\_

**ES204**  
Examination II  
January 19, 2007

Problem	Score
1	/20
2	/40
3	/40
Total	/100

Show all work for credit  
AND  
Turn in your signed help sheet  
AND  
Stay in your seat until the end of class

**The exam is closed-hard-drive. Laptop computers running Maple or other math software are permitted. Network connections are not allowed.**

**1a.** [8 points] Disk A rolls without slip over the horizontal surface. The bodies are pinned together at A, B, and C. Locate the instant center of the disk, and each bar.

**1b.** [6 points] Assuming the uniform bar AB has an angular velocity of 4 rad/s CCW at the instant shown, compute the linear momentum vector of bar AB. Assume  $m = 6$  kg.

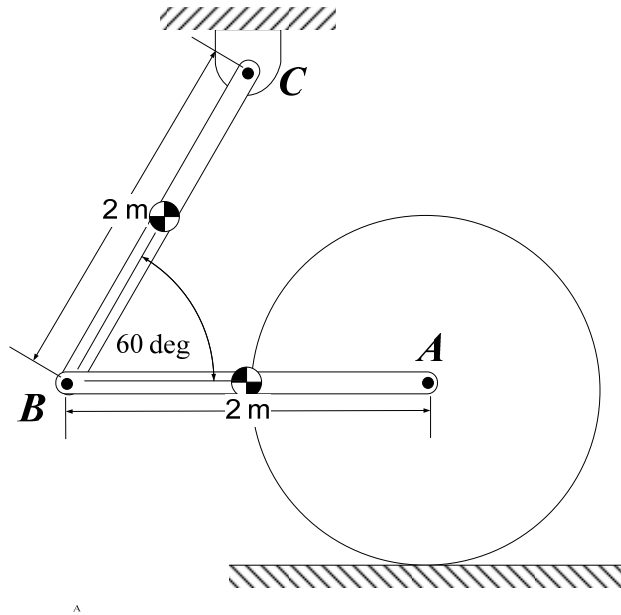

**1c.** [6 points] Calculate the bar's angular momentum,  $L$  about the pin at C assuming  $I_G = 2 \text{ kg}\cdot\text{m}^2$ .

Slender bar OA has length  $2r$  and mass  $2m$ . Slender bar AB has length  $\sqrt{2} r$  and mass  $m$ . Cylinder C has mass  $2m$  and radius  $r$ . All are initially at rest in position 1. The weight of each bar causes the cylinder to roll to the left without slipping as the bars rotate appropriately to position 2. In position 2 bar OA is vertical, bar AB makes a  $45^\circ$  angle as shown and point B is a vertical distance  $r$  from the floor. **Set-up but do not solve** the necessary equations to determine the angular velocity of the cylinder in position 2.

$$I_{G_{OA}} = \frac{2}{3}mr^2; \quad I_{G_{AB}} = \frac{1}{6}mr^2; \quad I_{G_C} = mr^2;$$

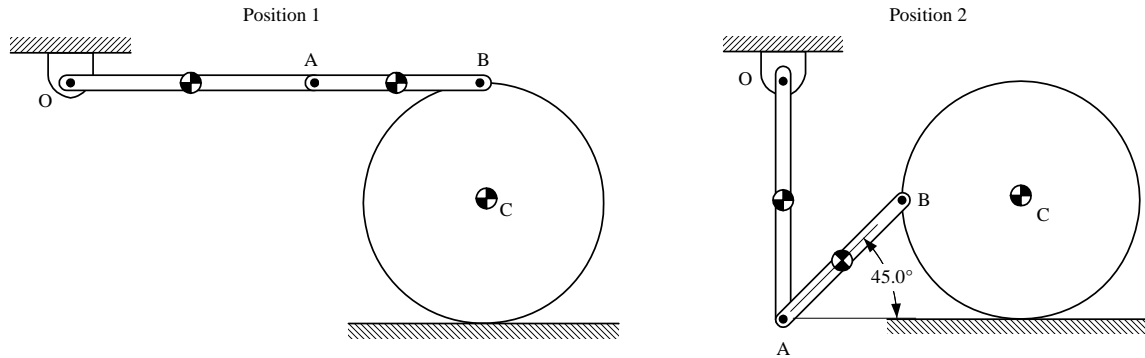



Two bars of length,  $L$ , are welded together with an angle of  $120^\circ$  between the bars as shown. The welded object is then pinned at B. Each individual bar has a mass  $m$  and a mass moment of inertia of  $I_G$ . A small glob of putty, D, of mass  $m_D$  strikes the end C of member ABC with a velocity  $v_0$  and the putty sticks to the bar. Determine the equations necessary to find:

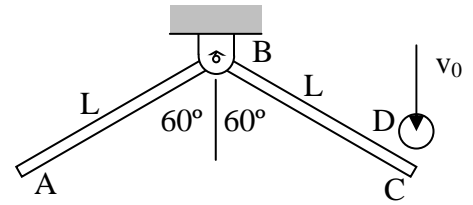

- a) angular velocity of ABC immediately after impact
- b) the reactions at B immediately **after** the impact

DO NOT SOLVE THE RESULTING EQUATIONS! Your answer should consist of numbered equations and a list of unknowns. Be sure to clearly document your solution.

