

Name _____ Section _____



Ho Ho Ho



ES204
Examination I
December 14, 2007

Problem	Score
1	/20
2	/40
4	/40
Total	/100

Show all work for credit
AND
Turn in your signed help sheet
AND
Stay in your seat until the end of class



Merry Christmas! Frohe Weihnachten!



Problem 1.1 (2 pts)

The system shown is released from rest in the position shown. Qualitatively the normal force between block A and B is (circle one)

- a) less than the weight of B
- b) equal to the weight of B
- c) greater than the weight of B

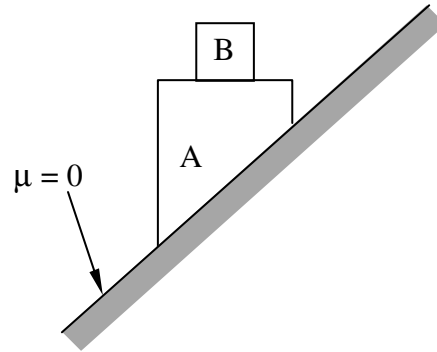

Problem 1.2 (2pts)

The system shown is released from rest in the position shown. Assume there is no friction between A and B. What is the direction of $\vec{a}_{A/B}$

- a) ←
- b) ↓
- c) ↙
- d) $\vec{a}_{A/B} = 0$

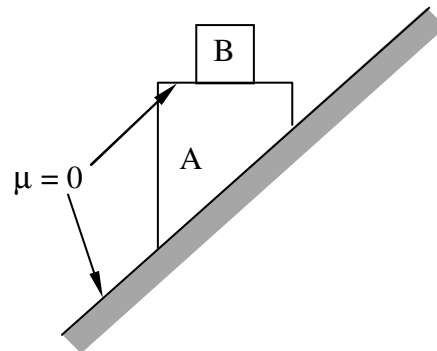

Problem 1.3 (2 pts)

A weight at the end of a string moves at a constant speed around a circle path in a horizontal plane as shown. Circle ALL the following statements that are correct.

What is the direction of the normal acceleration? Circle the correct direction.

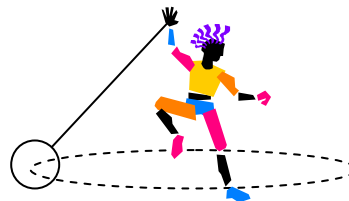
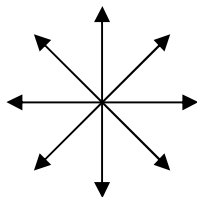

Problem 1.4 (4 pts)

For the system shown, determine a kinematic relationship between the accelerations of A, B and C.

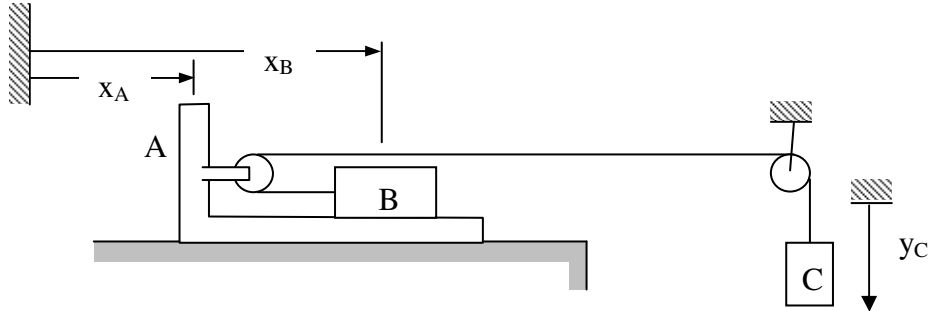

Problem 1.5 (4 pts)

The axis xy is attached to the rotating disk. The pin travels with respect to the disk at a constant 2.5 in/s in the direction shown. If the disk rotates with a constant angular velocity of 0.5 rad/s in a ccw direction, determine the speed of the pin in the position shown.

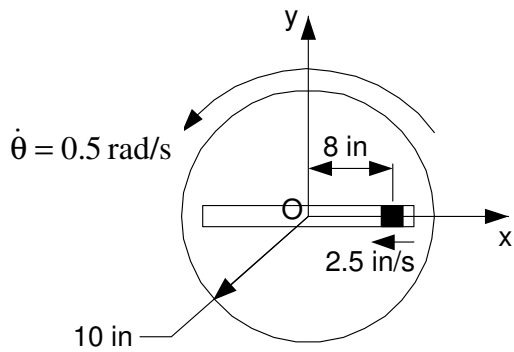

Problem 1.6 (3 pts)

A 50 lbf block is moved on a horizontal surface by a 100 lbf force as shown. If the block moves a distance of 2 ft. What is the work done by friction during this displacement? The normal force between the block and the ground is 50 lbf.

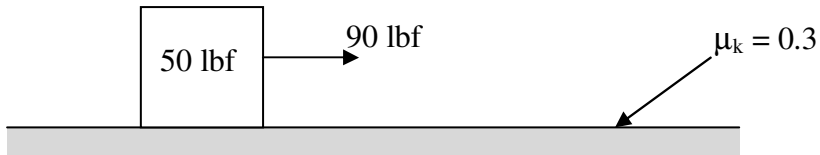

Problem 1.7 (3 pts)

For the situation shown below, what is the direction of the velocity of B with respect to A? Circle the best answer.

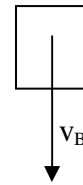
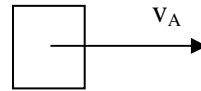
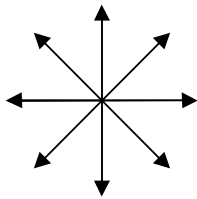

Ball B falls and collides with Block A which is initially stationary. The initial compression of the spring is x_0 . Friction on all surfaces is negligible. Determine, **but do not solve**, the equations to find the maximum spring deflection after the collision. Include any related diagrams used in developing these equations. Number the equations clearly, clearly document your work and list your unknowns.

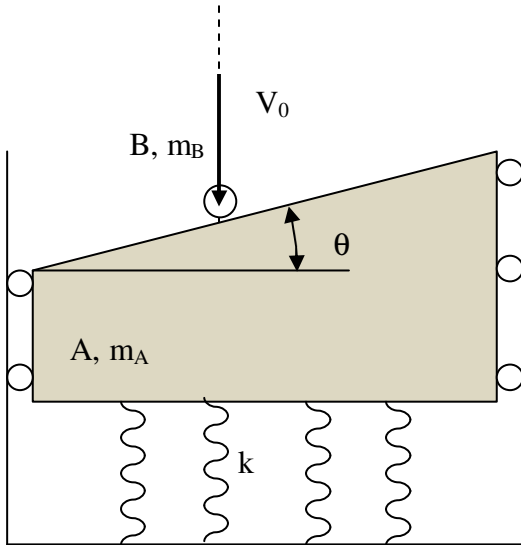

Known parameters	
Symbol	Definitions
m_A	Mass of A
m_B	Mass of B
V_0	A's velocity before impact
e	Coefficient of restitution
k	Spring constant
θ	Ramp Angle
g	Acceleration of gravity
x_0	Initial compression of spring

Unknowns

A small block of mass m slides at a known speed v_0 on a horizontal surface at a known height h above the ground. Determine the equations necessary to find:

- the angle θ at which it will leave the cylindrical surface BCD
- the distance x at which it will hit the ground.

Neglect friction and air resistance. **Do not solve the equations. Your answer should consist of a clear list of equations and unknowns. Clearly document your solution for full credit.**

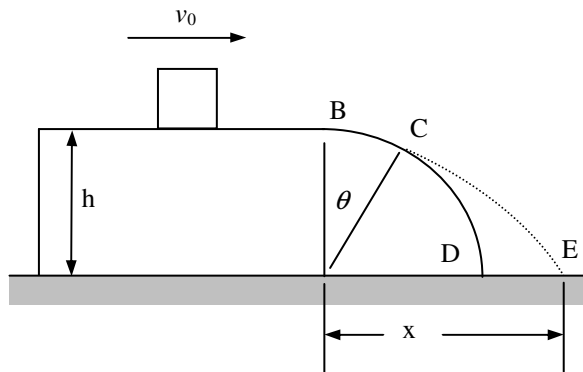

Unknowns