

NAME \_\_\_\_\_ BOX NUMBER \_\_\_\_\_

Problem 1 ( 30 ) \_\_\_\_\_

Problem 2 ( 30 ) \_\_\_\_\_

Problem 3 ( 40 ) \_\_\_\_\_

\_\_\_\_\_

Total ( 100 ) \_\_\_\_\_

### INSTRUCTIONS

- **Closed book/notes exam. (Unit conversion page provided)**
  - **Help sheet allowed. (8-1/2 x 11" sheet of paper, one side)**
  - **Laptops may be used; however, no pre-prepared worksheets or files may be used.**
- 1) Show all work for complete credit.
- Start all problems at the ANALYSIS stage, but clearly label any information you use for your solution.
  - **Problems involving conservation principles *MUST* clearly identify the system and show a clear, logical progression from the basic principle. [You may start with a simplified form of the basic principle if all of the pertinent simplifying assumptions are stated.]**
  - Don't expect us to read your mind as to how or why you did something in the solution. Clearly indicate how you arrived at your answer.
  - Always crunch numbers last on an exam. The final numerical answer is worth the least amount of points. (Especially if all I would have to do is plug in the numbers into a well-documented solution.)
- 2) Useful Rule of Thumb (Heuristic):  $(100 \text{ point exam}) / (50 \text{ min}) = 2 \text{ points/minute}$ . That means a 10 point problem is not worth more than 5 minutes of your time (at least the first time around).

STANDARD ACCELERATION OF GRAVITY:  $g = 9.810 \text{ m/s}^2 = 32.174 \text{ ft/s}$

UNIVERSAL GAS CONSTANT:  $R_u = 8.314 \text{ kJ/(kg-K)} = 1.986 \text{ Btu/(lbm-}^\circ\text{R)} = 1545 \text{ ft-lbf/(lbm-}^\circ\text{R)}$

**Problem 1** ( 30 points )

A light rod with a fixed collar of mass  $m = 10 \text{ kg}$  is initially at rest in the inclined position shown in the figure. It is then rotated counter-clockwise about the pivot  $B$  from rest by the constant force  $\mathbf{P}$  until it is brought to rest in the horizontal position by the linear spring which has a spring constant of  $k = 40 \text{ kN/m}$ . The spring is compressed from it's free (uncompressed) length by  $50 \text{ mm}$  when the rod comes to rest. Assume the mass of the rod is negligible.

- (a) Determine the work done by the force  $\mathbf{P}$  to rotate the rod from  $C_1$  to  $C_2$ , in joules.
- (b) Determine the magnitude of force  $\mathbf{P}$ , in newtons.

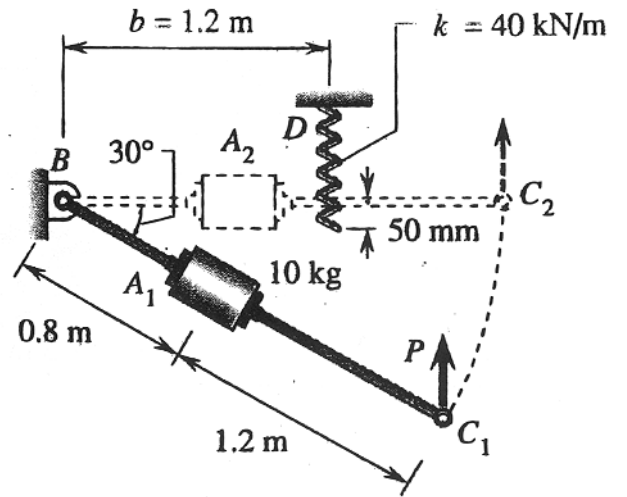

**Problem 3** ( 40 points )

A centrifugal pump is driven by an electric motor as shown in the figure. Water flows steadily through the pump with the inlet and outlet conditions shown in the figure. The 440-ac-volt electric motor receives 42 kW of electrical power and delivers 40 kW of shaft power to the pump under steady-state conditions. The motor rotates at 1750 rpm and has a power factor of unity. Assume that water can be modeled as an incompressible substance with constant specific heats, and assume changes in gravitational potential energy are negligible.

- (a) Determine the direction and magnitude of the heat transfer rate for the pump, in kilowatts.
- (b) Determine the torque transmitted by the motor shaft to the pump, in N-m.
- (c) Determine the electric current supplied to the motor, in amps.

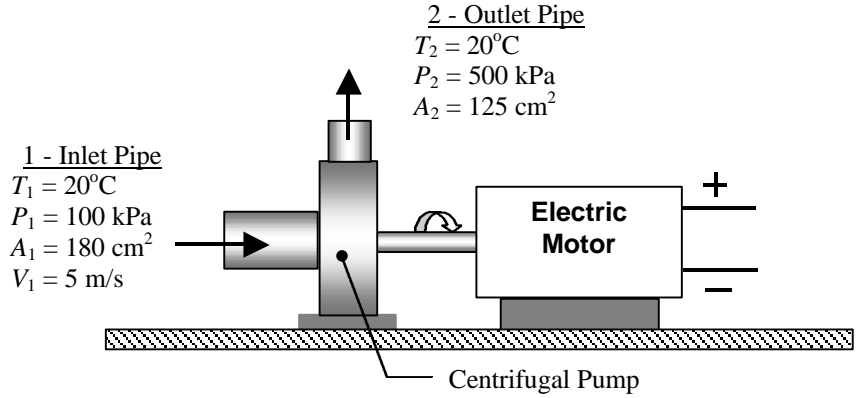

**Problem 2** ( 30 points )

A piston-cylinder device as shown in the figure contains helium gas. Initially, the gas has a pressure of 70 psia, a temperature of  $600^{\circ}\text{R}$ , and a volume of  $7\text{ ft}^3$ . During a process where  $PV = C$ , a constant, the helium is expanded to a final volume of  $28\text{ ft}^3$ . Assume that helium gas can be modeled as an ideal gas with constant specific heats and assume that changes in kinetic and potential energy are negligible.

Determine the direction and the magnitude of the work and the heat transfer for the helium gas, in ft-lbf.

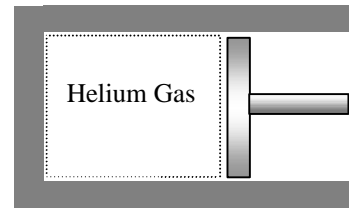

**Extra Work Space for Problem 3**