

# Connections between Math and Physics Pre-Requisites and Student Performance in an Introductory Circuits Course

**Dr. Carlotta A. Berry**

Department of Electrical and Computer Engineering

[cjohnson35@tnstate.edu](mailto:cjohnson35@tnstate.edu)

<http://www.tnstate.edu/cberry>

Infinite Possibilities Conference

Spelman College

April 1, 2005

## **Presentation Outline**

- Purpose
- Introduction
- Methods of Analysis
- Background
- Methods of Analysis
- Results
- Recommendations and Conclusions
- Questions

# Purpose

The primary purpose of this work is to identify factors that inhibit academic success and retention in engineering. The primary focus group is underrepresented minorities and women. The ultimate goal would be to identify solutions to alleviate these factors and reduce student attrition in engineering. This presentation will focus on the connections between pre-requisite courses and a lower-level engineering course

<b>Purpose</b>	Introduction	Methods	Background	Results	Recommendations
----------------	--------------	---------	------------	---------	-----------------

# Introduction

- TSU is an HBCU in Nashville, TN with an approximate enrollment of 9000
- College of Engineering, Technology, and Computer Science has an approximate enrollment of 10000
- There are 8 majors including graduate and undergraduate level degrees
- Circuits I is an introductory dc circuit analysis course required by all engineering majors (Civil, architectural, mechanical, and electrical engineering)
- Evaluated the performance of 300 students during the Fall 2000 through Spring 2003 semesters

Purpose	<b>Introduction</b>	Background	Methods	Results	Recommendations
---------	---------------------	------------	---------	---------	-----------------

## Background (Pre-requisites)

- Physics I - II and Calculus I-IV and programming are pre-requisites for Circuits I
- Physics II covers basic dc circuit analysis
- The main skill needed from calculus is integration and differentiation
- The programming is used for circuit analysis software and programming circuit solutions
- Differential equations is a co-requisite and the solution of first and second order differential equations is required to solve problems in the last third of the course

Purpose	Introduction	Background	Methods	Results	Recommendations
---------	--------------	------------	---------	---------	-----------------

# Background (Bloom's Taxonomy)

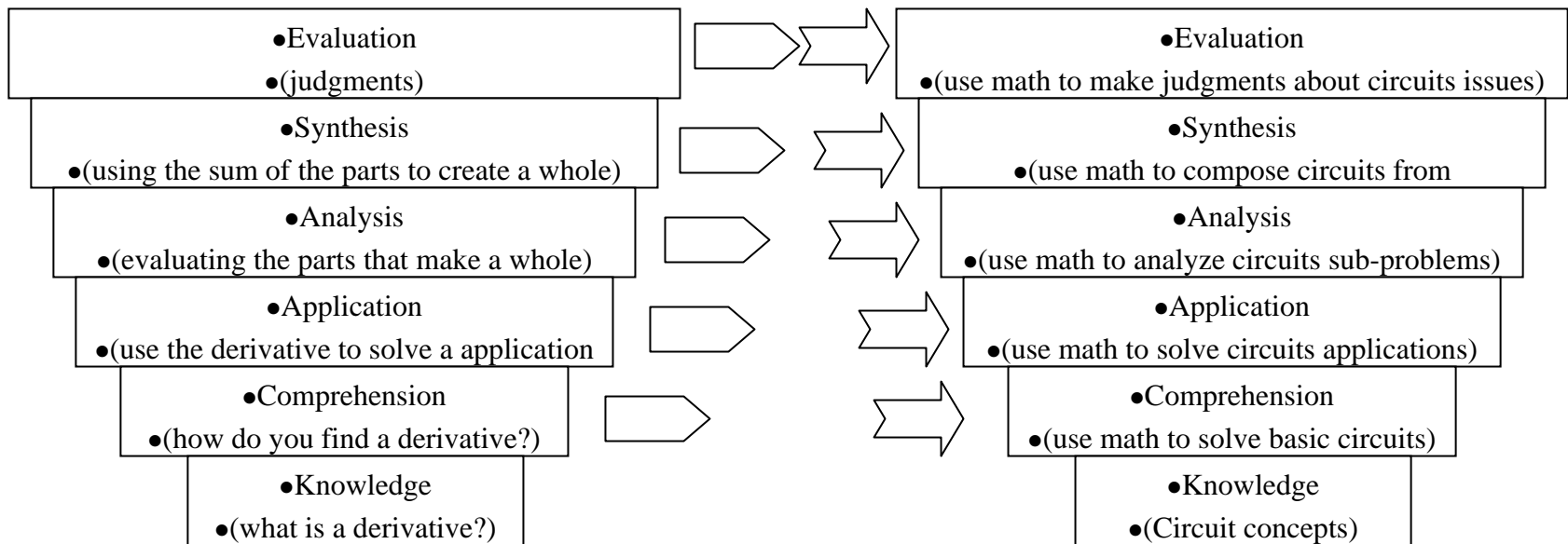

Purpose	Introduction	<b>Background</b>	Methods	Results	Recommendations
---------	--------------	-------------------	---------	---------	-----------------

## Background (Circuits example)

- A capacitor is a circuit element that stores voltage. Voltage can be used to provide power to electrical devices.
- The equation for the current through a capacitor is
- $i(t) = C \, dv/dt$  (amperes)

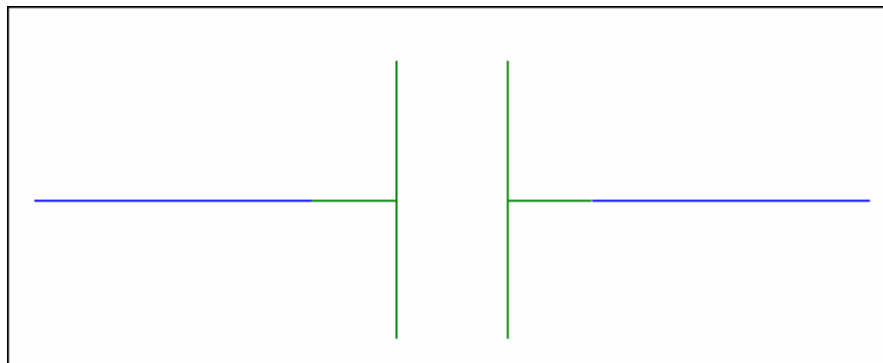

Purpose	Introduction	<b>Background</b>	Methods	Results	Recommendations
---------	--------------	-------------------	---------	---------	-----------------

# Background (Circuits example I)

- Sketch the current for the 1-mF capacitor with the following voltage?
- What is the voltage at 1 second for the 1-mF capacitor with the following current? (assume  $v(0) = 0V$ )

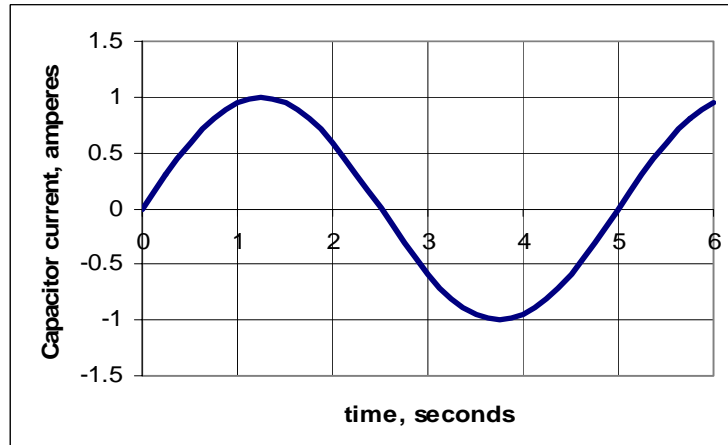
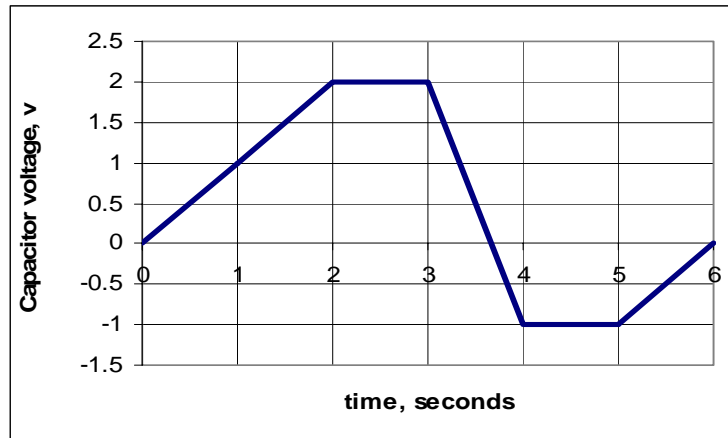

Purpose	Introduction	<b>Background</b>	Methods	Results	Recommendations
---------	--------------	-------------------	---------	---------	-----------------



# Background (Circuits example II)

- In the following two circuits, which 12-V light bulb will turn on first?

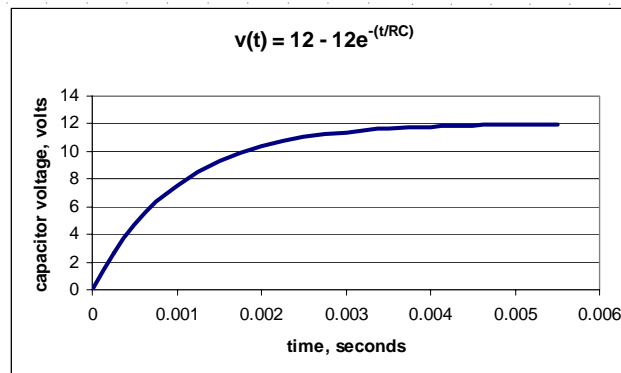
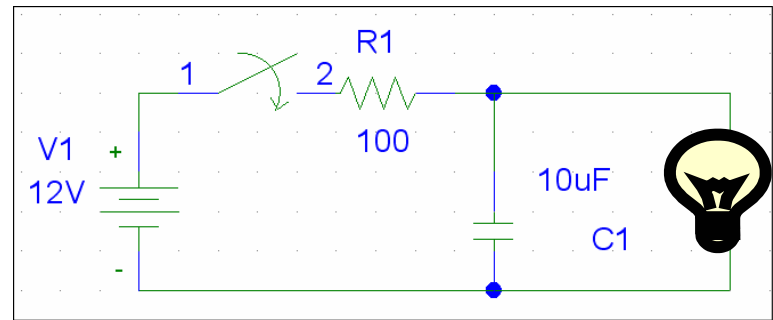
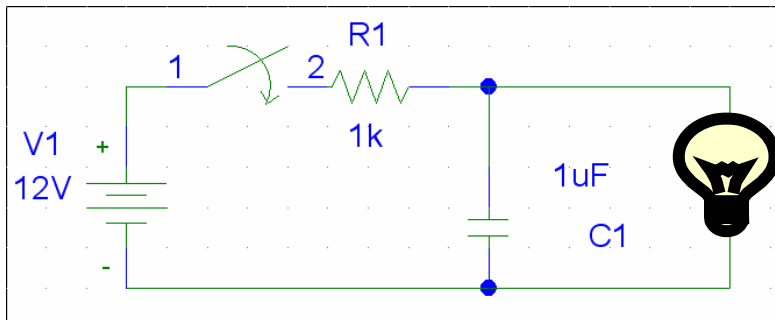

Purpose	Introduction	<b>Background</b>	Methods	Results	Recommendations
---------	--------------	-------------------	---------	---------	-----------------

# Methods of Analysis

- Descriptive statistics were performed in order to define the student population studied
- The correlations between course grades and pre-requisite grades were evaluated using SPSS, a statistical software package

Purpose	Introduction	Background	Methods	Results	Recommendations
---------	--------------	------------	---------	---------	-----------------

# Results (Descriptive Statistics)

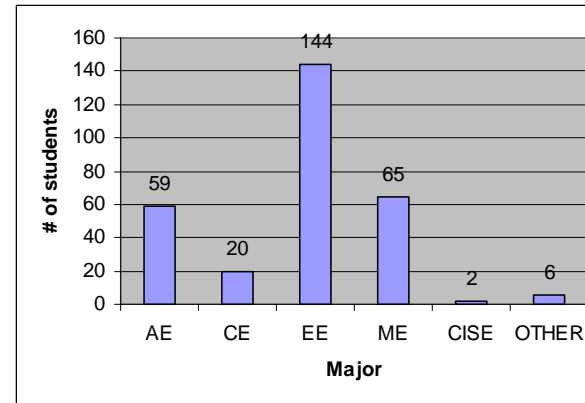
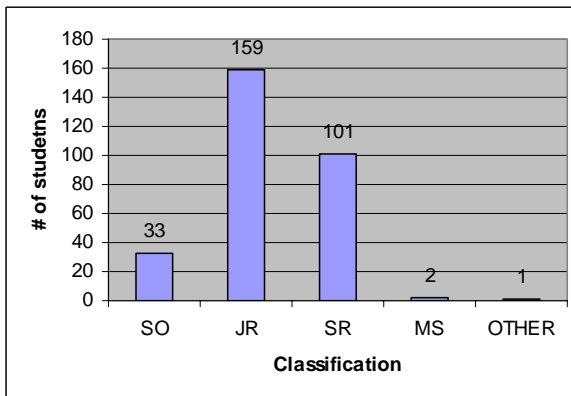
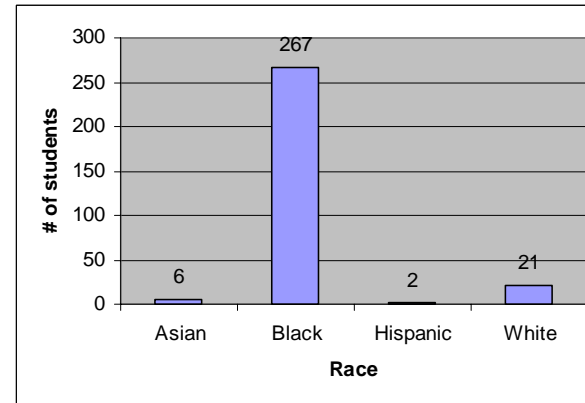
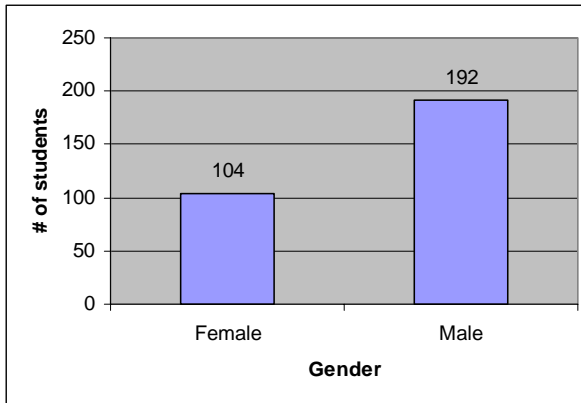

# Results (Quantitative Statistics)

- 33% attrition, mean grade point = 2.06
- Pre-requisite performance was significant at the 5% level (Kruskal-Wallis H test (non-parametric))
- Calculus (p-value = .013)
- Physics, Programming (p-value = .031)

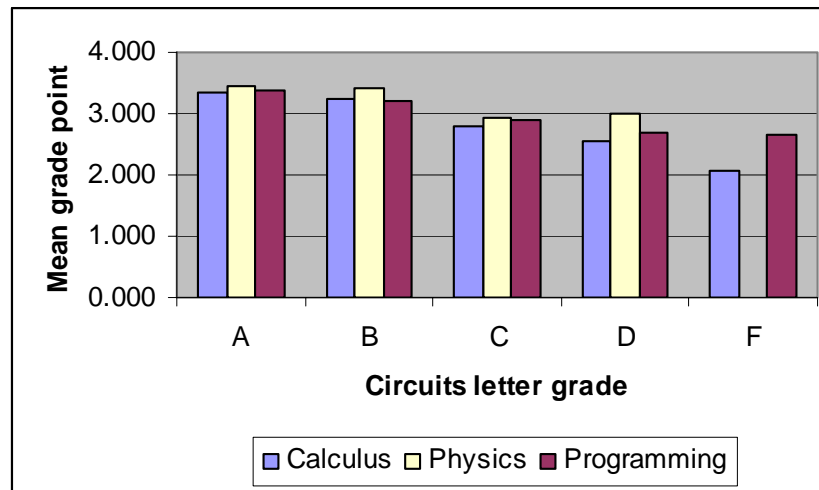

Purpose	Introduction	Background	Methods	<b>Results</b>	Recommendations
---------	--------------	------------	---------	----------------	-----------------

# Recommendations and Conclusions

- Mathematics education for science and engineering students should highlight the practicality and application of the theory presented
- Students must understand the relevance of the problem-solve techniques and methodologies presented in pre-requisite courses

Purpose

Introduction

Methods

Background

Results

Recommendations

# Recommendations and Conclusions

- Circuits I has been modified to include active learning activities and cooperative learning teams to address math deficiencies
- Learning teams are formed based upon learning styles, pre-requisite grades, student preferences, and concept inventories

Purpose

Introduction

Methods

Background

Results

Recommendations

## Relevant Publications

1. Berry, C.A., "The re-design of an introductory circuits course based upon student demographics", Paper submitted to the Proceedings of the 35th ASEE/IEEE Frontiers in Education Conference, Indianapolis, Indiana, October 19 - 22, 2005.
2. Berry, C.A., "The influence of demographics on an introductory Circuits course", Paper submitted to the Proceedings of the 2005 American Society of Engineering Education Conference and Exposition, Portland Oregon, June 12-15, 2005.

# Questions



**Dr. Carlotta A. Berry**

cjohnson35@tnstate.edu

<http://www.tnstate.edu/cberry>