

MERI: Multidisciplinary Educational Robotics Initiative

Carlotta Berry

Matthew Boutell

Steve Chenoweth

David Fisher

Rose-Hulman Institute of Technology



Introduction

- Multidisciplinary Robotics Certificate Program
- Collaborative effort between faculty in
 - Computer Science and Software Engineering (CSSE),
 - Electrical and Computer Engineering (ECE),
 - Mechanical Engineering (ME)
- A **certificate** is a minor across multiple disciplines
- The certificate curriculum was approved in Fall, 2008



Presentation Outline

- ***Why?*** Motivation for a Robotics Certificate
- ***What?*** Certificate Outcomes
- ***How?*** Certificate Details
- ***Who?*** First Graduates
- Assessment
- Future Work



Motivation – Why a Robotics Program?

- **Recruitment**

- Attracts students to **science** and **engineering** based upon success of FIRST and BotBall
- Illustrates **connections** between engineering and computing
- Capitalizes on high school students' **existing interest**
- Facilitated by **outreach** by faculty and students in the program
- Attracts more **faculty** with robotics expertise



Motivation – Why a Robotics Program?

- **Multidisciplinary teamwork**
 - **Robots** are mechanical systems with electrical controls and sensors, given intelligence through software
 - Ideal for collaborative teamwork and the integration of multiple disciplines
 - Certificate students will have a deeper and broader exposure to their respective majors
 - More realistic team demographic for the workforce
 - Real world application of classroom theory



Motivation – Why a Robotics Program?

- **Industry Demand**

- Industry partners have stated that they would like to hire graduates who
 - understand connections between different fields
 - can work with peers in other disciplines
 - are scientists and engineers who are specialists in their field but know enough about another field to apply their knowledge
- Certificate students will learn invaluable skills in teamwork and the application of conceptual knowledge even if their careers do not include robotics



Robotics Certificate Outcomes

- Increased **number** of students enrolled in our institution with interest in robotics
- More **interaction** between students of various majors via the multidisciplinary senior design project and certificate curriculum courses
- Increased **marketability** of certificate graduates



Robotics Certificate Requirements

- Students major in a robotics-related discipline (CSSE, ECE, ME) for depth while gaining breadth in a second area
- Three Certificate Requirements (7 courses):

Introduction to Robotics Programming (year 1)



A robotics certificate **track** including an elective (6 courses; years 2-4). Examples:
EE with Mechanics
CSSE with Hardware



Multidisciplinary robotics senior design project (year 4)



Majors with breadth in another area can work together successfully

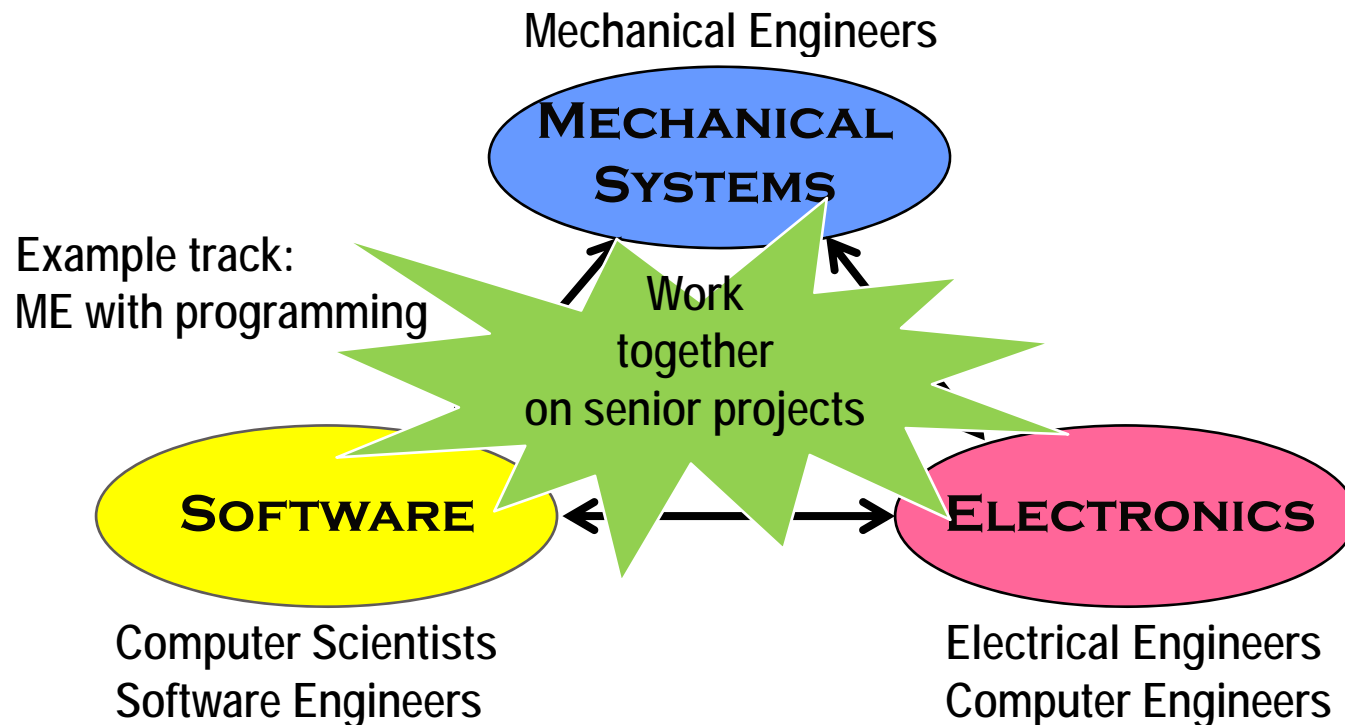



Robotics Certificate Tracks

- Currently students have enrolled in 7 of the 9 following tracks, the most popular tracks are **highlighted**
 - CSSE with Controls
 - CSSE with Hardware
 - CSSE with Mechanics
 - **Computer Engineering**
 - EE with Programming
 - **ECE with Sensors**
 - EE with Mechanics
 - ME with Electronics
 - **ME with Programming**



Robotics Elective Courses

- **Computer Science**
 - Artificial Intelligence, Computer Vision, Image Recognition, Swarm Intelligence
- **Electrical and Computer Engineering**
 - Controls, Wireless Systems, Signals and Systems
- **Mechanical Engineering**
 - Kinematics, Controls, Robotics Engineering
- **Physics and Optical Engineering**
 - Microsensors, Image Processing



Select CSSE Required Course: Introduction to Software Development (Robotics Programming)

- First required course in freshman year
- Python and C programming
- Create (Roomba) robots with bump, cliff and IR sensors
- Button and MIDI I/O
- Line following, wall following, robot tracking
- Co-taught among PIs





Select ME Required and Elective Courses: Mechatronics, Robotics Engineering

- **Mechatronics** is required for all ME and Robotics students
- Has microprocessor and microcontroller programming
- Design of embedded systems related to robotics
- Interfaces software with hardware
- C programming

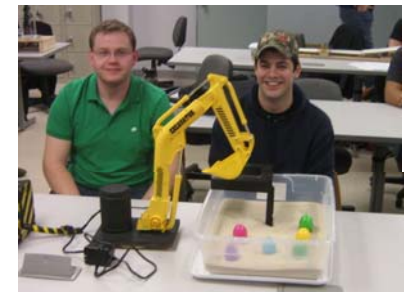
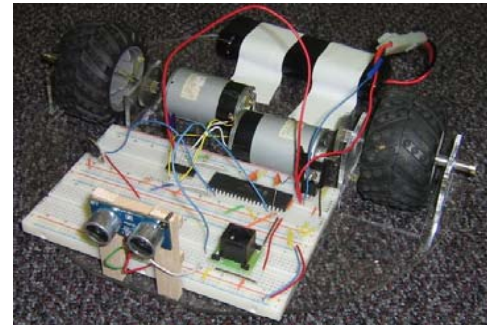

Robotics Engineering

- Robotic Arm
- MATLAB GUI programming
- More microprocessors
- Communication protocol



Select ECE Required Course: Introduction to Mobile Robotics

- Microsoft Visual C#
- Microsoft Robotics Studio
- Traxster II Robot
- Locomotion, Navigation, Kinematics, Artificial Intelligence
- Feedback Control, Behavior-based control, Hybrid Control
- IR, sonar, thermopile, line sensors, I/O board, keypad, LCD, speech synthesizer
- Homing, Wall Following, Line Following, Obstacle Avoidance

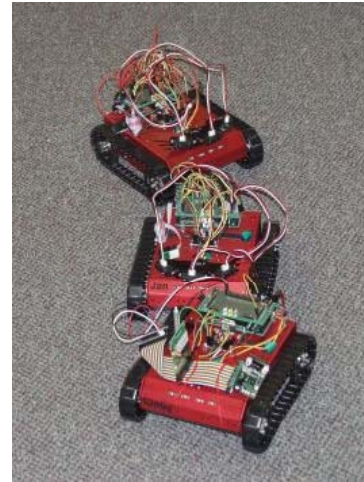



First Graduates (May, 2009)

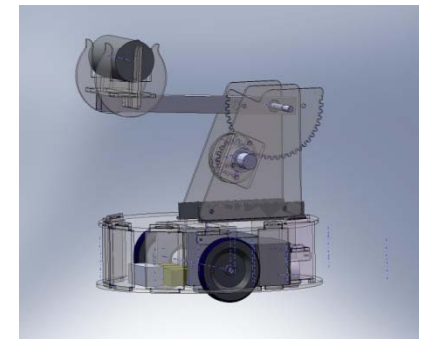

B.S. Mechanical Engineering	M.S. Engr. Management Thesis: "Secondary School Robotics Education Business Plan"	B.S. Mechanical Engineering
ME/Programming	ME/Programming	ME/Electronics
Articulated Robotic Manipulator for BRT Robotic Transport (Beckman Coulter)	Sodabot	Beckman Coulter
Robotics consultant	Automation expert	Graduate school in Robotics



Assessment

- The initial year has had a positive reception from the students and employers
- Department heads have stated that prospective students have expressed interest in the robotics certificate
- Current upperclassmen have expressed a desire to earn the certificate
- A multidisciplinary senior design course has been created and 6 students will enroll in fall 2009
- One industry partner has already expressed interest in hiring our graduates



Certificate Enrollment, 2008-2009

	ME	ECE	CSSE	TOTAL
Masters	2	0	0	2
Fourth-Year	2	0	0	2
Third-Year	3	1	0	4
Second-Year	6	4	2	12
First-Year	9	7	3	19
Total	22	12	5	39



Future Work

1. Seek federal and industry sponsorship for long term sustainability of the robotics certificate program
2. Develop an integrated robotics research laboratory
3. Develop and modify courses in the curriculum
4. Perform formative and summative assessment of the program outcomes
5. Begin the outreach and dissemination component of the program



Carlotta Berry , Assistant Professor
Electrical and Computer Engineering
Controls and Mobile robotics



Matthew Boutell, Assistant Professor
Computer Science and Software Engineering
Software development and Computer vision



Steve Chenoweth, Associate Professor
Computer Science and Software Engineering
Artificial intelligence



David Fisher, Assistant Professor
Mechanical Engineering
Mechatronics

For further information

<http://robotics.rose-hulman.edu>