

# TL598C, TL598Q, TL598M, TL598Y PULSE-WIDTH-MODULATION CONTROL CIRCUITS

SLVS053B – FEBRUARY 1988 – REVISED OCTOBER 1995

- Complete PWM Power Control Function
- Totem-Pole Outputs for 200-mA Sink or Source Current
- Output Control Selects Parallel or Push-Pull Operation
- Internal Circuitry Prohibits Double Pulse at Either Output
- Variable Dead-Time Provides Control Over Total Range
- Internal Regulator Provides a Stable 5-V Reference Supply, Trimmed to 1% Tolerance
- On-Board Output Current-Limiting Protection
- Undervoltage Lockout for Low  $V_{CC}$  Conditions
- Separate Power and Signal Grounds
- TL598Q Has Extended Temperature Range . . .  $-40^{\circ}\text{C}$  to  $125^{\circ}\text{C}$

## description

The TL598 incorporates all the functions required in the construction of pulse-width-modulated (PWM) controlled systems on a single monolithic chip. Designed primarily for power supply control, the TL598 provides the systems engineer with the flexibility to tailor the power supply control circuits to a specific application.

The TL598 contains two error amplifiers, an internal oscillator (externally adjustable), a dead-time control (DTC) comparator, a pulse-steering flip-flop, a 5-V precision reference, undervoltage lockout control, and output control circuits. Two totem-pole outputs provide exceptional rise and fall time performance for power FET control. The outputs share a common source supply and common power ground terminals, which allow system designers to eliminate errors caused by high current-induced voltage drops and common-mode noise.

**D, J, OR N PACKAGE  
(TOP VIEW)**

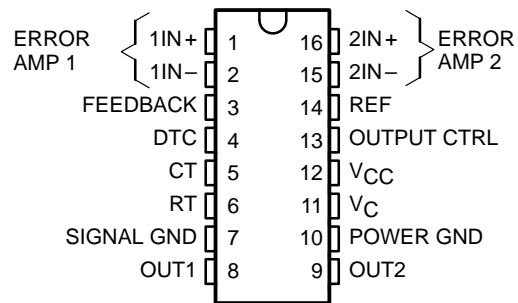

**FK PACKAGE  
(TOP VIEW)**

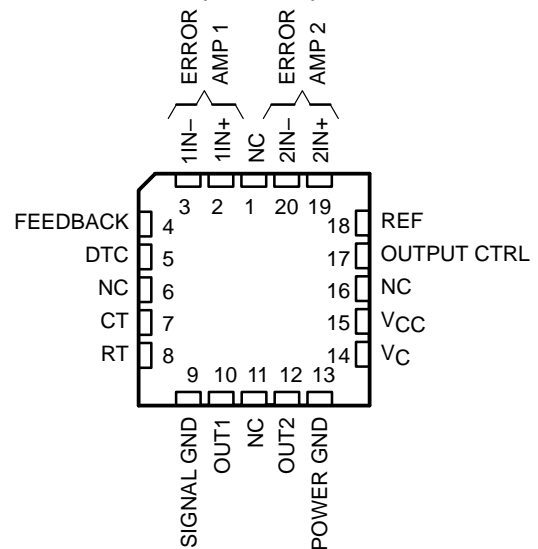

NC—No internal connection

**FUNCTION TABLE**

INPUT	OUTPUT FUNCTION
$V_I = \text{GND}$	Single-ended or parallel output
$V_I = \text{REF}$	Normal push-pull operation

## AVAILABLE OPTIONS

$T_A$	PACKAGED DEVICES				CHIP FORM (Y)
	SMALL OUTLINE (D)	CHIP CARRIER (FK)	CERAMIC DIP (J)	PLASTIC DIP (N)	
$0^{\circ}\text{C}$ to $70^{\circ}\text{C}$	TL598CD	—	—	TL598CN	TL598Y
$-40^{\circ}\text{C}$ to $125^{\circ}\text{C}$	TL598QD	—	—	TL598QN	
$-55^{\circ}\text{C}$ to $125^{\circ}\text{C}$	—	TL598MFK	TL598MJ	—	

Chip forms are tested at  $25^{\circ}\text{C}$ .

PRODUCTION DATA information is current as of publication date. Products conform to specifications per the terms of Texas Instruments standard warranty. Production processing does not necessarily include testing of all parameters.

 **TEXAS  
INSTRUMENTS**

POST OFFICE BOX 655303 • DALLAS, TEXAS 75265

Copyright © 1995, Texas Instruments Incorporated

On products compliant to MIL-STD-883, Class B, all parameters are tested unless otherwise noted. On all other products, production processing does not necessarily include testing of all parameters.

# TL598C, TL598Q, TL598M, TL598Y

## PULSE-WIDTH-MODULATION CONTROL CIRCUITS

SLVS053B – FEBRUARY 1988 – REVISED OCTOBER 1995

The error amplifier has a common-mode voltage range from 0 V to  $V_{CC} - 2$  V. The DTC comparator has a fixed offset that prevents overlap of the outputs during push-pull operation. A synchronous multiple supply operation may be achieved by connecting RT to the reference output and providing a sawtooth input to CT.

The TL598 device provides an output control function to select either push-pull or parallel operation. Circuit architecture prevents either output from being pulsed twice during push-pull operation. The output frequency for push-pull applications is one-half the oscillator frequency ( $f_o = \frac{1}{2 RT CT}$ ). For single-ended applications:

$$f_o = \frac{1}{RT CT}$$

The TL598C is characterized for operation from 0°C to 70°C. The TL598Q is characterized for operation from -40°C to 125°C. The TL598M is characterized for operation from -55°C to 125°C.

### functional block diagram

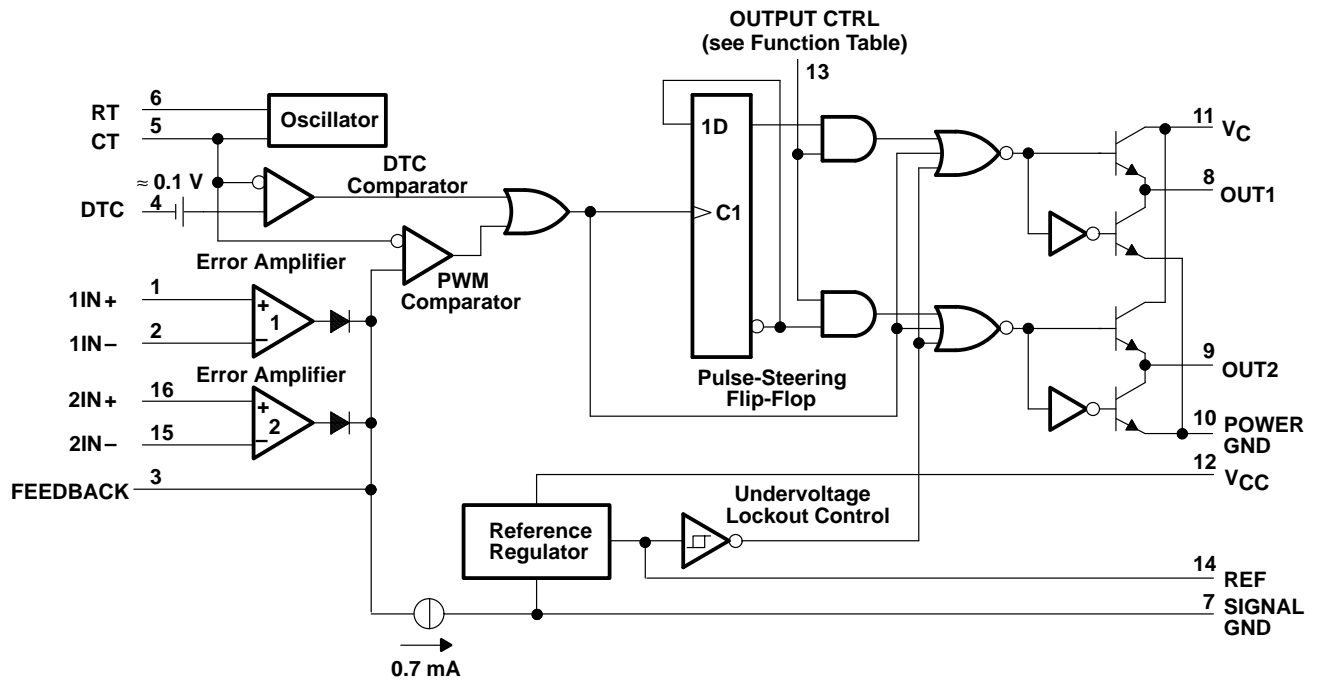

# TL598C, TL598Q, TL598M, TL598Y PULSE-WIDTH-MODULATION CONTROL CIRCUITS

SLVS053B – FEBRUARY 1988 – REVISED OCTOBER 1995

## TL598Y chip information

This chip, when properly assembled, displays characteristics similar to the TL598C. Thermal compression or ultrasonic bonding can be used on the doped aluminum bonding pads. The chip can be mounted with conductive epoxy or a gold-silicon preform.

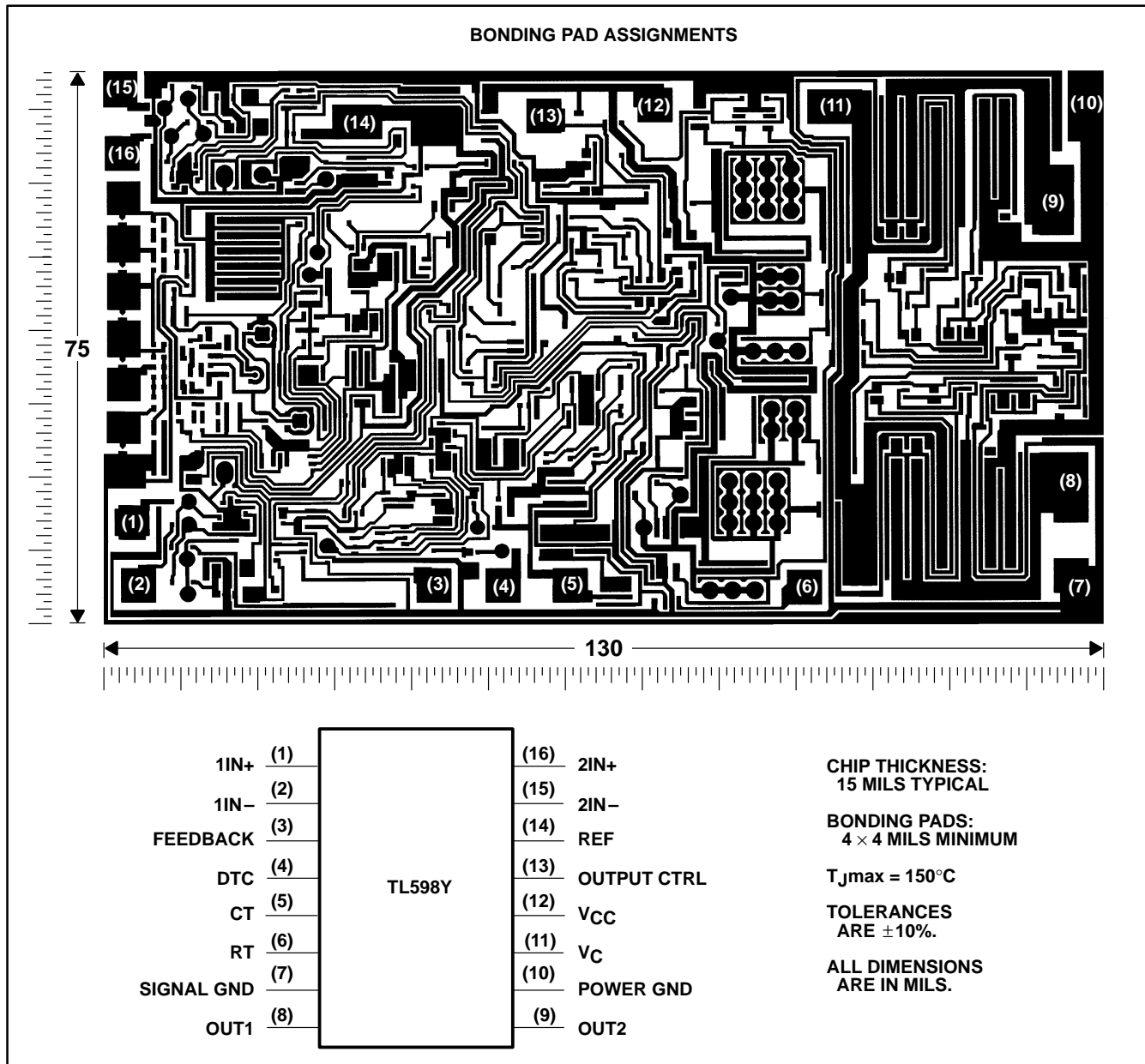

# TL598C, TL598Q, TL598M, TL598Y PULSE-WIDTH-MODULATION CONTROL CIRCUITS

SLVS053B – FEBRUARY 1988 – REVISED OCTOBER 1995

## absolute maximum ratings over operating free-air temperature range (unless otherwise noted)†

Supply voltage, $V_{CC}$ (see Note 1)	41 V
Amplifier input voltage, $V_I$	$V_{CC} + 0.3$ V
Collector voltage	41 V
Output current (each output), sink or source, $I_O$	250 mA
Continuous total power dissipation	See Dissipation Rating Table
Operating virtual junction temperature range, $T_J$ : TL598C	0°C to 150°C
TL598Q	-40°C to 150°C
TL598M	-55°C to 150°C
Storage temperature range, $T_{stg}$	-65°C to 150°C
Case temperature for 60 seconds, $T_C$ : FK package	260°C
Lead temperature 1,6 mm (1/16 inch) from case for 10 seconds: D or N packages	260°C
Lead temperature 1,6 mm (1/16 inch) from case for 60 seconds: J package	300°C

† Stresses beyond those listed under “absolute maximum ratings” may cause permanent damage to the device. These are stress ratings only, and functional operation of the device at these or any other conditions beyond those indicated under “recommended operating conditions” is not implied. Exposure to absolute-maximum-rated conditions for extended periods may affect device reliability.

NOTE 1: All voltage values, except differential voltages, are with respect to the signal ground terminal.

DISSIPATION RATING TABLE

PACKAGE	$T_A \leq 25^\circ\text{C}$ POWER RATING	DERATING FACTOR ABOVE $T_A = 25^\circ\text{C}$	$T_A = 70^\circ\text{C}$ POWER RATING	$T_A = 125^\circ\text{C}$ POWER RATING
D	950 mW	7.6 mW/°C	608 mW	190 mW
FK	1375 mW	11 mW/°C	880 mW	275 mW
J	1375 mW	11 mW/°C	800 mW	275 mW
N	1150 mW	9.2 mW/°C	736 mW	230 mW

## recommended operating conditions

	MIN	MAX	UNIT
Supply voltage, $V_{CC}$	7	40	V
Amplifier input voltage, $V_I$	0	$V_{CC} - 2$	V
Collector voltage		40	V
Output current (each output), sink or source, $I_O$		200	mA
Current into feedback terminal, $I_{FL}$		0.3	mA
Timing capacitor, $C_T$	0.00047	10	$\mu\text{F}$
Timing resistor, $R_T$	1.8	500	$\text{k}\Omega$
Oscillator frequency, $f_{osc}$	1	300	kHz
Operating free-air temperature, $T_A$	TL598C	0	70
	TL598Q	-40	125
	TL598M	-55	125
			°C



# TL598C, TL598Q, TL598M, TL598Y PULSE-WIDTH-MODULATION CONTROL CIRCUITS

SLVS053B – FEBRUARY 1988 – REVISED OCTOBER 1995

**electrical characteristics over recommended operating free-air temperature range,  $V_{CC} = 15\text{ V}$  (unless otherwise noted)**

**reference section (see Note 2)**

PARAMETER	TEST CONDITIONS†		TL598C			TL598Q			UNIT
			MIN	TYP‡	MAX	MIN	TYP‡	MAX	
Output voltage (REF)	$I_O = 1\text{ mA}$	$T_A = 25^\circ\text{C}$	4.95	5	5.05	4.95	5	5.05	V
		$T_A = \text{MIN to MAX}$		4.9	5.1	4.9		5.1	
Input regulation	$V_{CC} = 7\text{ V to }40\text{ V}$			2	25		2	22	mV
Output regulation	$I_O = 1\text{ mA to }10\text{ mA}$	$T_A = 25^\circ\text{C}$		1	15		1	15	mV
		$T_A = \text{MIN to MAX}$			50			80	
Output voltage change with temperature	$\Delta T_A = \text{MIN to MAX}$			2	10		2	10	mV/V
Short-circuit output current§	REF = 0 V		-10	-48		-10	-48		mA

† For conditions shown as MIN or MAX, use the appropriate value specified under recommended operating conditions.

‡ All typical values except for parameter changes with temperature are at  $T_A = 25^\circ\text{C}$ .

§ Duration of the short circuit should not exceed one second.

NOTE 2: Pulse-testing techniques that maintain the junction temperature as close to the ambient temperature as possible must be used.

**oscillator section,  $C_T = 0.001\ \mu\text{F}$ ,  $R_T = 12\ \text{k}\Omega$  (see Figure 1) (see Note 2)**

PARAMETER	TEST CONDITIONS†	TL598C, TL598Q			UNIT
		MIN	TYP‡	MAX	
Frequency			100		kHz
Standard deviation of frequency¶	All values of $V_{CC}$ , $C_T$ , $R_T$ , $T_A$ constant		100		Hz/kHz
Frequency change with voltage	$V_{CC} = 7\text{ V to }40\text{ V}$ , $T_A = 25^\circ\text{C}$		1	10	Hz/kHz
Frequency change with temperature#	$\Delta T_A = \text{MIN to MAX}$		70	120	Hz/kHz
	$\Delta T_A = \text{MIN to MAX}$ , $C_T = 0.01\ \mu\text{F}$		50	80	

† For conditions shown as MIN or MAX, use the appropriate value specified under recommended operating conditions.

‡ All typical values except for parameter changes with temperature are at  $T_A = 25^\circ\text{C}$ .

¶ Standard deviation is a measure of the statistical distribution about the mean as derived from the formula:  $\sigma = \sqrt{\frac{\sum_{n=1}^N (x_n - \bar{X})^2}{N - 1}}$

# Effects of temperature on external  $R_T$  and  $C_T$  are not taken into account.

NOTE 2: Pulse-testing techniques that maintain the junction temperature as close to the ambient temperature as possible must be used.

**error amplifier section (see Note 2)**

PARAMETER	TEST CONDITIONS	TL598C, TL598Q			UNIT
		MIN	TYP‡	MAX	
Input offset voltage	FEEDBACK = 2.5 V		2	10	mV
Input offset current	FEEDBACK = 2.5 V		25	250	nA
Input bias current	FEEDBACK = 2.5 V		0.2	1	$\mu\text{A}$
Common-mode input voltage range	$V_{CC} = 7\text{ V to }40\text{ V}$		0 to $V_{CC}-2$		V
Open-loop voltage amplification	$\Delta V_O$ (FEEDBACK) = 3 V, $V_O$ (FEEDBACK) = 0.5 V to 3.5 V		70	95	dB
Unity-gain bandwidth			800		kHz
Common-mode rejection ratio	$V_{CC} = 40\text{ V}$ , $\Delta V_{IC} = 6.5\text{ V}$ , $T_A = 25^\circ\text{C}$		65	80	dB
Output sink current (FEEDBACK)	FEEDBACK = 0.5 V		0.3	0.7	mA
Output source current (FEEDBACK)	FEEDBACK = 3.5 V		-2		mA
Phase margin at unity gain	FEEDBACK = 0.5 V to 3.5 V, $R_L = 2\ \text{k}\Omega$		65°		
Supply voltage rejection ratio	FEEDBACK = 2.5 V, $\Delta V_{CC} = 33\text{ V}$ , $R_L = 2\ \text{k}\Omega$		100		dB

‡ All typical values except for parameter changes with temperature are at  $T_A = 25^\circ\text{C}$ .

NOTE 2: Pulse-testing techniques that maintain the junction temperature as close to the ambient temperature as possible must be used.



# TL598C, TL598Q, TL598M, TL598Y

## PULSE-WIDTH-MODULATION CONTROL CIRCUITS

SLVS053B – FEBRUARY 1988 – REVISED OCTOBER 1995

electrical characteristics over recommended operating free-air temperature range,  $V_{CC} = 15\text{ V}$  (unless otherwise noted)

### undervoltage lockout section (see Note 2)

PARAMETER	TEST CONDITIONS†	TL598C		TL598Q		UNIT
		MIN	MAX	MIN	MAX	
Threshold voltage	$T_A = 25^\circ\text{C}$	4	6	4	6	V
	$\Delta T_A = \text{MIN to MAX}$	3.5	6.9	3	6.9	
Hysteresis‡	$T_A = 25^\circ\text{C}$	100		100		mV
	$T_A = \text{MIN to MAX}$	50		30		

† For conditions shown as MIN or MAX, use the appropriate value specified under recommended operating conditions.

‡ Hysteresis is the difference between the positive-going input threshold voltage and the negative-going input threshold voltage.

NOTE 2: Pulse-testing techniques must be used that maintain the junction temperature as close to the ambient temperature as possible.

### output section (see Note 2)

PARAMETER	TEST CONDITIONS	TL598C, TL598Q		UNIT
		MIN	MAX	
High-level output voltage	$V_{CC} = 15\text{ V}$ , $V_C = 15\text{ V}$	$I_O = -200\text{ mA}$		V
		$I_O = -20\text{ mA}$		
Low-level output voltage	$V_{CC} = 15\text{ V}$ , $V_C = 15\text{ V}$	$I_O = 200\text{ mA}$		V
		$I_O = 20\text{ mA}$		
Output control input current	$V_I = V_{ref}$	3.5		mA
	$V_I = 0.4\text{ V}$	100		

NOTE 2: Pulse-testing techniques must be used that maintain the junction temperature as close to the ambient temperature as possible.

### dead-time control section (see Figure 1) (see Note 2)

PARAMETER	TEST CONDITIONS	TL598C			TL598Q			UNIT
		MIN	TYP§	MAX	MIN	TYP§	MAX	
Input bias current (DTC)	$V_I = 0\text{ to }5.25\text{ V}$	-2	-10		-2	-25		$\mu\text{A}$
Maximum duty cycle, each output	DTC = 0 V	0.45			0.45			
Input threshold voltage (DTC)	Zero duty cycle	3			3.2			V
	Maximum duty cycle	0			0			

§ All typical values except for parameter changes with temperature are at  $T_A = 25^\circ\text{C}$ .

NOTE 2: Pulse-testing techniques must be used that maintain the junction temperature as close to the ambient temperature as possible.

### pwm comparator section (see Note 2)

PARAMETER	TEST CONDITIONS	TL598C, TL598Q			UNIT	
		MIN	TYP§	MAX		
Input threshold voltage (FEEDBACK)	DTC = 0 V	3.75			4.5	V
Input sink current (FEEDBACK)	$V(\text{FEEDBACK}) = 0.5\text{ V}$	0.3	0.7			mA

§ All typical values except for parameter changes with temperature are at  $T_A = 25^\circ\text{C}$ .

NOTE 2: Pulse-testing techniques must be used that maintain the junction temperature as close to the ambient temperature as possible.

### total device (see Figure 1) (see Note 2)

PARAMETER	TEST CONDITIONS	TL598C, TL598Q			UNIT	
		MIN	TYP§	MAX		
Standby supply current	$R_T = V_{ref}$ , All other inputs and outputs open	$V_{CC} = 15\text{ V}$		15	21	mA
		$V_{CC} = 40\text{ V}$		20	26	
Average supply current	DTC = 2 V	15				mA

§ All typical values except for parameter changes with temperature are at  $T_A = 25^\circ\text{C}$ .

NOTE 2: Pulse-testing techniques must be used that maintain the junction temperature as close to the ambient temperature as possible.



# TL598C, TL598Q, TL598M, TL598Y PULSE-WIDTH-MODULATION CONTROL CIRCUITS

SLVS053B – FEBRUARY 1988 – REVISED OCTOBER 1995

**electrical characteristics over recommended operating free-air temperature range,  $V_{CC} = 15\text{ V}$  (unless otherwise noted)**

**switching characteristics,  $T_A = 25^\circ\text{C}$  (see Note 2)**

PARAMETER	TEST CONDITIONS	TL598C, TL598Q			UNIT
		MIN	TYP	MAX	
Output voltage rise time	CL = 1500 pF, VC = 15 V, VCC = 15 V, See Figure 2		60	150	ns
Output voltage fall time			35	75	

NOTE 2: Pulse-testing techniques must be used that maintain the junction temperature as close to the ambient temperature as possible.

**reference section (see Note 2)**

PARAMETER	TEST CONDITIONS†	TL598M			UNIT	
		MIN	TYP‡	MAX		
Output voltage (REF)	$I_O = 1\text{ mA}$	$T_A = 25^\circ\text{C}$	4.95	5	5.05	V
		$T_A = \text{MIN to MAX}$	4.9		5.1	
Input regulation	$V_{CC} = 7\text{ V to }40\text{ V}$	$T_A = 25^\circ\text{C}$	2	22	mV	
Output regulation	$I_O = 1\text{ mA to }10\text{ mA}$	$T_A = 25^\circ\text{C}$	1	15	mV	
		$T_A = \text{MIN to MAX}$		80		
Output voltage change with temperature	$\Delta T_A = \text{MIN to MAX}$		0.5%			
Short-circuit output current§	REF = 0		-10	-48	mA	

† For conditions shown as MIN or MAX, use the appropriate value specified under recommended operating conditions.

‡ All typical values except for parameter changes with temperature are at  $T_A = 25^\circ\text{C}$ .

§ Duration of the short circuit should not exceed one second.

NOTE 2: Pulse-testing techniques must be used that maintain the junction temperature as close to the ambient temperature as possible.

**oscillator section,  $C_T = 0.001\ \mu\text{F}$ ,  $R_T = 12\ \text{k}\Omega$  (see Figure 1) (see Note 2)**

PARAMETER	TEST CONDITIONS†	TL598M			UNIT
		MIN	TYP‡	MAX	
Frequency			100		kHz
Standard deviation of frequency¶	All values of $V_{CC}$ , $C_T$ , $R_T$ , $T_A$ constant		10%		
Frequency change with voltage	$V_{CC} = 7\text{ V to }40\text{ V}$ , $T_A = 25^\circ\text{C}$		0.1%	1%	
Frequency change with temperature#	$\Delta T_A = \text{MIN to MAX}$		7%	15%*	

\* On products compliant to MIL-STD-883, Class B, this parameter is not production tested.

† For conditions shown as MIN or MAX, use the appropriate value specified under recommended operating conditions.

‡ All typical values except for parameter changes with temperature are at  $T_A = 25^\circ\text{C}$ .

¶ Standard deviation is a measure of the statistical distribution about the mean as derived from the formula:

# Effects of temperature on external  $R_T$  and  $C_T$  are not taken into account.

$$\sigma = \sqrt{\frac{\sum_{n=1}^N (x_n - X)^2}{N - 1}}$$

NOTE 2: Pulse-testing techniques that maintain the junction temperature as close to the ambient temperature as possible must be used.



# TL598C, TL598Q, TL598M, TL598Y

## PULSE-WIDTH-MODULATION CONTROL CIRCUITS

SLVS053B – FEBRUARY 1988 – REVISED OCTOBER 1995

electrical characteristics over recommended operating free-air temperature range,  $V_{CC} = 15\text{ V}$  (unless otherwise noted)

error amplifier section (see Note 2)

PARAMETER	TEST CONDITIONS	TL598M			UNIT
		MIN	TYP†	MAX	
Input offset voltage	FEEDBACK at 2.5 V		2	10	mV
Input offset current	FEEDBACK at 2.5 V		25	250	nA
Input bias current	FEEDBACK at 2.5 V		0.2	1	$\mu\text{A}$
Common-mode input voltage range	$V_{CC} = 7\text{ V}$ to 40 V		0 to $V_{CC}-2$		V
Open-loop voltage amplification	$\Delta V_O$ (FEEDBACK) = 3 V, $V_O$ (FEEDBACK) = 0.5 V to 3.5 V		70	95	dB
Unity-gain bandwidth			800		kHz
Common-mode rejection ratio	$V_{CC} = 40\text{ V}$ , $\Delta V_{IC} = 6.5\text{ V}$ , $T_A = 25^\circ\text{C}$		65	80	dB
Output sink current (FEEDBACK)	FEEDBACK at 0.5 V		0.3	0.7	mA
Output source current (FEEDBACK)	FEEDBACK at 3.5 V		-2		mA
Phase margin at unity gain	FEEDBACK at 0.5 V to 3.5 V, $R_L = 2\text{ k}\Omega$		65°		
Supply voltage rejection ratio	FEEDBACK at 2.5 V, $\Delta V_{CC} = 33\text{ V}$ , $R_L = 2\text{ k}\Omega$		100		dB

† All typical values except for parameter changes with temperature are at  $T_A = 25^\circ\text{C}$ .

NOTE 2: Pulse-testing techniques must be used that maintain the junction temperature as close to the ambient temperature as possible.

undervoltage lockout section (see Note 2)

PARAMETER	TEST CONDITIONS‡	TL598M		UNIT
		MIN	MAX	
Threshold voltage	$T_A = 25^\circ\text{C}$	4	6	V
	$\Delta T_A = \text{MIN to MAX}$	3	6.9	
Hysteresis§	$T_A = 25^\circ\text{C}$	100		mV
	$T_A = \text{MIN to MAX}$	30		

‡ For conditions shown as MIN or MAX, use the appropriate value specified under recommended operating conditions.

§ Hysteresis is the difference between the positive-going input threshold voltage and the negative-going input threshold voltage.

NOTE 2: Pulse-testing techniques must be used that maintain the junction temperature as close to the ambient temperature as possible.

output section (see Note 2)

PARAMETER	TEST CONDITIONS	TL598M			UNIT
		MIN	TYP	MAX	
Collector off-state current	$V_{CE} = 40\text{ V}$ , $V_{CC} = 40\text{ V}$ , DTC connected to 0 V		2	100	$\mu\text{A}$
High-level output voltage	$V_{CC} = 15\text{ V}$ , $I_O = -200\text{ mA}$		12		V
	$V_C = 15\text{ V}$ , $I_O = -20\text{ mA}$		13		
Low-level output voltage	$V_{CC} = 15\text{ V}$ , $I_O = 200\text{ mA}$			2	V
	$V_C = 15\text{ V}$ , $I_O = 20\text{ mA}$			0.4	
Output control input current	$V_I = \text{REF}$			3.5	mA
	$V_I = 0.4\text{ V}$			100	$\mu\text{A}$

NOTE 2: Pulse-testing techniques must be used that maintain the junction temperature as close to the ambient temperature as possible.



# TL598C, TL598Q, TL598M, TL598Y PULSE-WIDTH-MODULATION CONTROL CIRCUITS

SLVS053B – FEBRUARY 1988 – REVISED OCTOBER 1995

**electrical characteristics over recommended operating free-air temperature range,  $V_{CC} = 15\text{ V}$  (unless otherwise noted)**

**dead-time control section (see Figure 1) (see Note 2)**

PARAMETER	TEST CONDITIONS	TL598M			UNIT
		MIN	TYP†	MAX	
Input bias current (DTC)	$V_I = 0$ to $5.25\text{ V}$		-2	-25	$\mu\text{A}$
Maximum duty cycle, each output	DTC at $0\text{ V}$	45%*			
Input threshold voltage (DTC)	Zero duty cycle		3	3.2	V
	Maximum duty cycle	0*			

\* On products compliant to MIL-STD-883, Class B, this parameter is not production tested.

† All typical values except for parameter changes with temperature are at  $T_A = 25^\circ\text{C}$ .

NOTE 2: Pulse-testing techniques must be used that maintain the junction temperature as close to the ambient temperature as possible.

**pwm comparator section (see Note 2)**

PARAMETER	TEST CONDITIONS	TL598M			UNIT
		MIN	TYP†	MAX	
Input threshold voltage (FEEDBACK)	DTC = $0\text{ V}$		3.75	4.5	V
Input sink current (FEEDBACK)	$V(\text{FEEDBACK}) = 0.5\text{ V}$	0.3	0.7		mA

† All typical values except for parameter changes with temperature are at  $T_A = 25^\circ\text{C}$ .

NOTE 2: Pulse-testing techniques must be used that maintain the junction temperature as close to the ambient temperature as possible.

**total device (see Figure 1) (see Note 2)**

PARAMETER	TEST CONDITIONS	TL598M			UNIT
		MIN	TYP†	MAX	
Standby supply current	RT at REF, All other inputs and outputs open	$V_{CC} = 15\text{ V}$	15	21	mA
		$V_{CC} = 40\text{ V}$	20	26	
Average supply current	DTC at $2\text{ V}$	15			mA

NOTE 2: Pulse-testing techniques must be used that maintain the junction temperature as close to the ambient temperature as possible.

**switching characteristics,  $T_A = 25^\circ\text{C}$  (see Note 2)**

PARAMETER	TEST CONDITIONS	TL598M			UNIT
		MIN	TYP	MAX	
Output voltage rise time	CL = $1500\text{ pF}$ , See Figure 2	$V_C = 15\text{ V}$ , $V_{CC} = 15\text{ V}$			ns
Output voltage fall time		150*			
		75*			

\* On products compliant to MIL-STD-883, Class B, this parameter is not production tested.

NOTE 2: Pulse-testing techniques must be used that maintain the junction temperature as close to the ambient temperature as possible.



# TL598C, TL598Q, TL598M, TL598Y

## PULSE-WIDTH-MODULATION CONTROL CIRCUITS

SLVS053B – FEBRUARY 1988 – REVISED OCTOBER 1995

**electrical characteristics,  $V_{CC} = 15\text{ V}$ ,  $T_A = 25^\circ\text{C}$**

**reference section (see Note 2)**

PARAMETER	TEST CONDITIONS	TL598Y			UNIT
		MIN	TYP†	MAX	
Output voltage (REF)	$I_O = 1\text{ mA}$		5		V
Input regulation	$V_{CC} = 7\text{ V to }40\text{ V}$		2		mV
Output regulation	$I_O = 1\text{ mA to }10\text{ mA}$		1		mV
Output voltage change with temperature	$\Delta T_A = \text{MIN to MAX}$		2		mV/V
Short-circuit output current‡	REF = 0 V		-48		mA

† All typical values except for parameter changes with temperature are at  $T_A = 25^\circ\text{C}$ .

‡ Duration of the short circuit should not exceed one second.

NOTE 2 Pulse-testing techniques that maintain the junction temperature as close to the ambient temperature as possible must be used.

**oscillator section,  $C_T = 0.001\ \mu\text{F}$ ,  $R_T = 12\ \text{k}\Omega$  (see Figure 1) (see Note 2)**

PARAMETER	TEST CONDITIONS	TL598Y			UNIT
		MIN	TYP	MAX	
Frequency			100		kHz
Standard deviation of frequency§	All values of $V_{CC}$ , $C_T$ , $R_T$ , $T_A$ constant		100		Hz/kHz
Frequency change with voltage	$V_{CC} = 7\text{ V to }40\text{ V}$ ,		1		Hz/kHz

§ Standard deviation is a measure of the statistical distribution about the mean as derived from the formula:

$$\sigma = \sqrt{\frac{\sum_{n=1}^N (x_n - X)^2}{N - 1}}$$

NOTE 2 Pulse-testing techniques that maintain the junction temperature as close to the ambient temperature as possible must be used.

**error amplifier section (see Note 2)**

PARAMETER	TEST CONDITIONS	TL598Y			UNIT
		MIN	TYP	MAX	
Input offset voltage	Feedback = 2.5 V		2		mV
Input offset current	Feedback = 2.5 V		25		nA
Input bias current	Feedback = 2.5 V		0.2		$\mu\text{A}$
Open-loop voltage amplification	$\Delta V_O$ (FEEDBACK) = 3 V, $V_O$ (FEEDBACK) = 0.5 V to 3.5 V		95		dB
Unity-gain bandwidth			800		kHz
Common-mode rejection ratio	$V_{CC} = 40\text{ V}$ , $\Delta V_{IC} = 6.5\text{ V}$ ,		80		dB
Output sink current (FEEDBACK)	FEEDBACK = 0.5 V		0.7		mA
Phase margin at unity gain	FEEDBACK = 0.5 V to 3.5 V, $R_L = 2\ \text{k}\Omega$		65°		
Supply voltage rejection ratio	FEEDBACK = 2.5 V, $\Delta V_{CC} = 33\text{ V}$ , $R_L = 2\ \text{k}\Omega$		100		dB

NOTE 2 Pulse-testing techniques that maintain the junction temperature as close to the ambient temperature as possible must be used.

# TL598C, TL598Q, TL598M, TL598Y PULSE-WIDTH-MODULATION CONTROL CIRCUITS

SLVS053B – FEBRUARY 1988 – REVISED OCTOBER 1995

**electrical characteristics,  $V_{CC} = 15\text{ V}$ ,  $T_A = 25^\circ\text{C}$**

**dead-time control section (see Figure 1) (see Note 2)**

PARAMETER	TEST CONDITIONS	TL598Y			UNIT
		MIN	TYP	MAX	
Input bias current (DTC)	$V_I = 0$ to $5.25\text{ V}$		-2		$\mu\text{A}$
Input threshold voltage (DTC)	Zero duty cycle		3		V

NOTE 2 Pulse-testing techniques that maintain the junction temperature as close to the ambient temperature as possible must be used.

**pwm comparator section (see Note 2)**

PARAMETER	TEST CONDITIONS	TL598Y			UNIT
		MIN	TYP	MAX	
Input threshold voltage (FEEDBACK)	DTC = 0 V		3.75		V
Input sink current (FEEDBACK)	FEEDBACK = 0.5 V		0.7		mA

NOTE 2 Pulse-testing techniques that maintain the junction temperature as close to the ambient temperature as possible must be used.

**total device (see Figure 1) (see Note 2)**

PARAMETER	TEST CONDITIONS	TL598Y			UNIT
		MIN	TYP	MAX	
Standby supply current	RT = $V_{ref}$ , All other inputs and outputs open	$V_{CC} = 15\text{ V}$	15		mA
		$V_{CC} = 40\text{ V}$	20		
Average supply current	DTC = 2 V		15		mA

NOTE 2 Pulse-testing techniques that maintain the junction temperature as close to the ambient temperature as possible must be used.

# TL598C, TL598Q, TL598M, TL598Y PULSE-WIDTH-MODULATION CONTROL CIRCUITS

SLVS053B – FEBRUARY 1988 – REVISED OCTOBER 1995

## PARAMETER MEASUREMENT INFORMATION

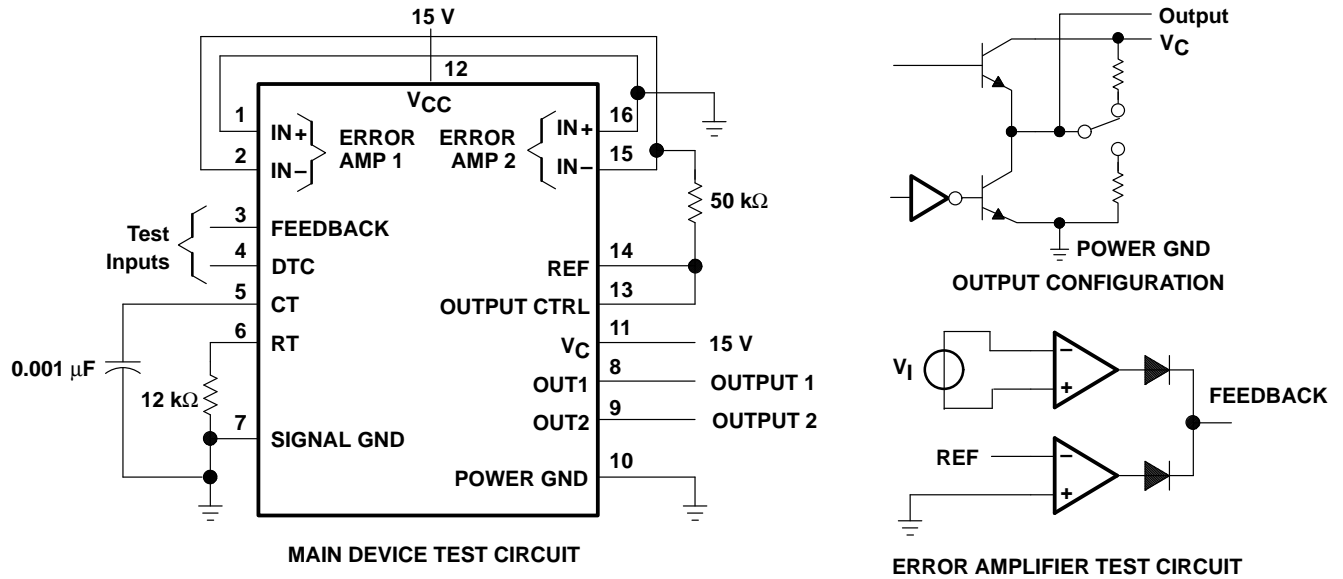

Figure 1. Test Circuits

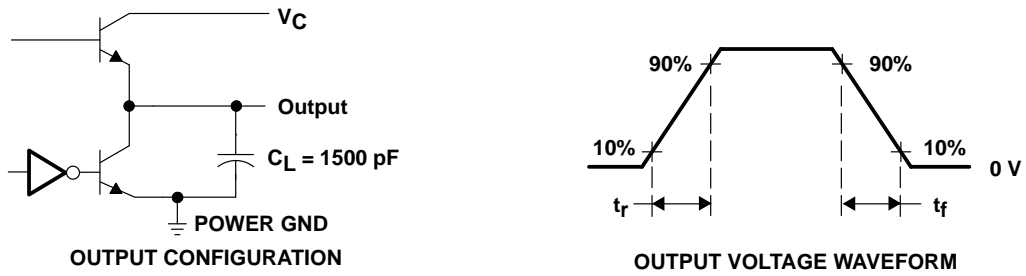
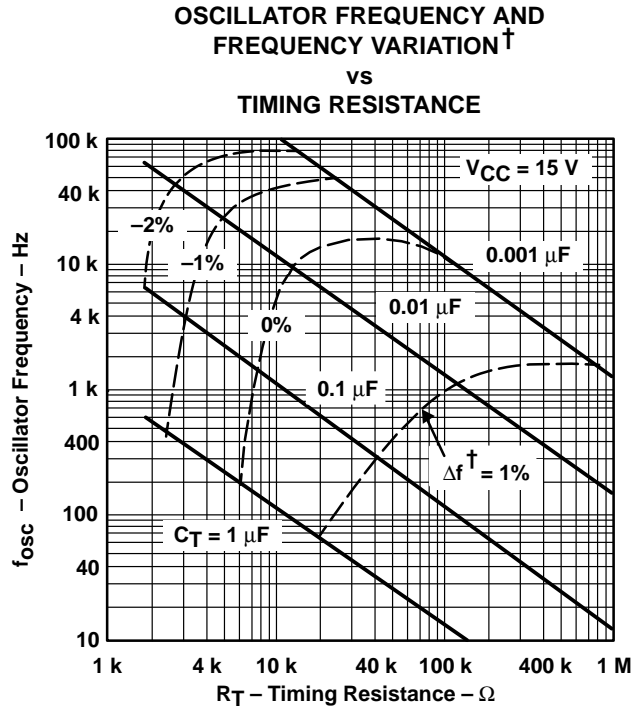

Figure 2. Switching Output Configuration and Voltage Waveform

TYPICAL CHARACTERISTICS



<sup>†</sup> Frequency variation ( $\Delta f$ ) is the change in predicted oscillator frequency that occurs over the full temperature range.

Figure 3

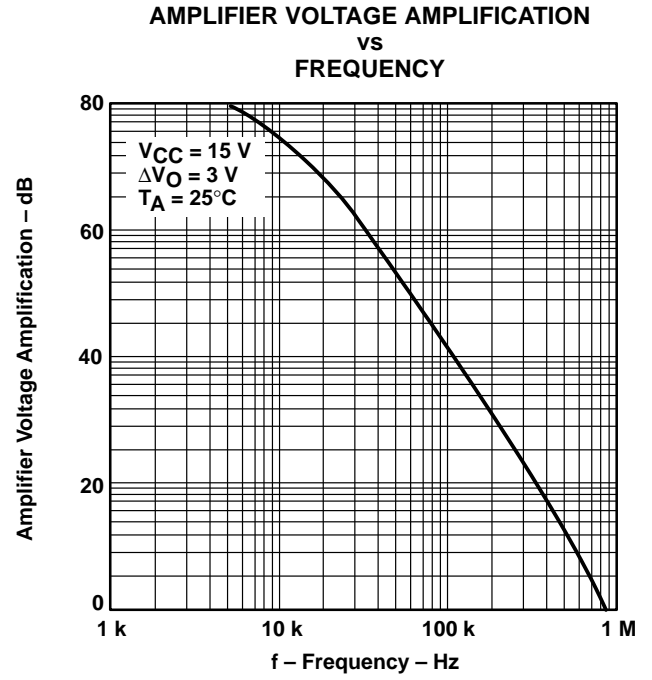

Figure 4



## **IMPORTANT NOTICE**

Texas Instruments (TI) reserves the right to make changes to its products or to discontinue any semiconductor product or service without notice, and advises its customers to obtain the latest version of relevant information to verify, before placing orders, that the information being relied on is current.

TI warrants performance of its semiconductor products and related software to the specifications applicable at the time of sale in accordance with TI's standard warranty. Testing and other quality control techniques are utilized to the extent TI deems necessary to support this warranty. Specific testing of all parameters of each device is not necessarily performed, except those mandated by government requirements.

Certain applications using semiconductor products may involve potential risks of death, personal injury, or severe property or environmental damage ("Critical Applications").

**TI SEMICONDUCTOR PRODUCTS ARE NOT DESIGNED, INTENDED, AUTHORIZED, OR WARRANTED TO BE SUITABLE FOR USE IN LIFE-SUPPORT APPLICATIONS, DEVICES OR SYSTEMS OR OTHER CRITICAL APPLICATIONS.**

Inclusion of TI products in such applications is understood to be fully at the risk of the customer. Use of TI products in such applications requires the written approval of an appropriate TI officer. Questions concerning potential risk applications should be directed to TI through a local SC sales office.

In order to minimize risks associated with the customer's applications, adequate design and operating safeguards should be provided by the customer to minimize inherent or procedural hazards.

TI assumes no liability for applications assistance, customer product design, software performance, or infringement of patents or services described herein. Nor does TI warrant or represent that any license, either express or implied, is granted under any patent right, copyright, mask work right, or other intellectual property right of TI covering or relating to any combination, machine, or process in which such semiconductor products or services might be or are used.