

Pulse magnetics help keep the “simple” in National Semiconductor’s Simple Switchers™. All our standard magnetics designed for the Simple Switchers™ are included in this easy to use data sheet.

These inductors and transformers have been fully tested and recommended by National Semiconductor for their DC/DC voltage conversion circuits. These Pulse parts can also be used as general purpose parts for many other DC/DC voltage conversions and SMPS requirements.

For pricing and availability, call your local distributor or our sales offices listed on the back cover of this data sheet. For additional product information, contact us for our full line of Power Products or call our Applications Engineering Department in San Diego.

POWER MAGNETICS FOR THE SIMPLE SWITCHER™ POWER CONVERTER FAMILY



Table of Contents

INDUCTORS FOR NATIONAL'S SIMPLE SWITCHER™

150 KHz SIMPLE SWITCHER™2-3
 52 KHz SIMPLE SWITCHER™4-6

TRANSFORMERS FOR NATIONAL'S SIMPLE SWITCHER™

100 KHz SIMPLE SWITCHER™7
 52 KHz SIMPLE SWITCHER™8

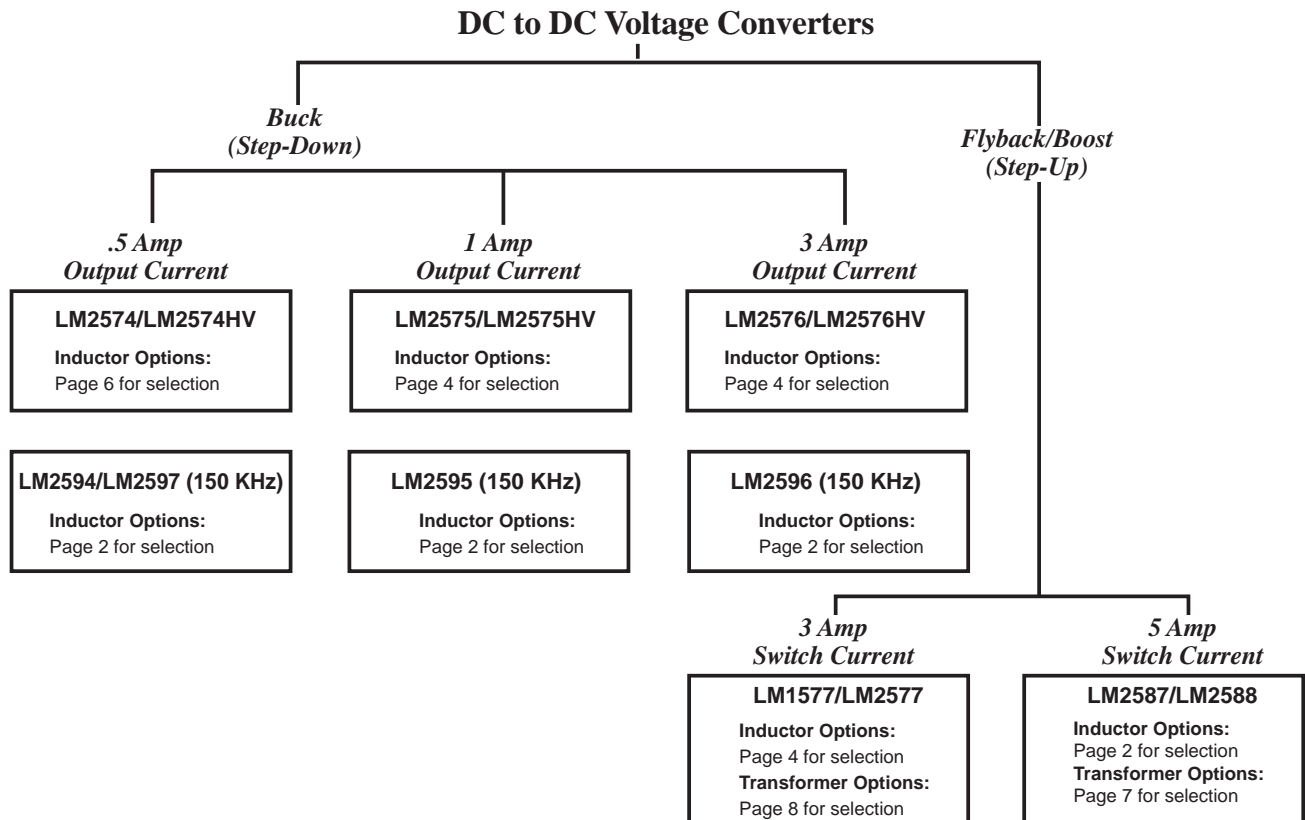

WEIGHT AND PAN SIZE INFORMATION9

Inductor and Transformer Selection Guide for National Semiconductor Simple Switchers™



INDUCTORS DESIGNED FOR NATIONAL'S 150 KHz SIMPLE SWITCHER™



- 
 Tested and recommended by National Semiconductor
- 
 Base material meets flammability requirements of UL 94V-0
- 
 Available in surface mount and through hole versions

Electrical Specifications @ 25°C— Operating Temperature -30° to +130° C

Pulse THT Part Number	Pulse SMT Part Number	National Part Number	In Circuit Operating Parameters ⁽¹⁾			Nominal DCR (Ω)	Package	
			Nominal Inductance (μH)	Rated Current (Amps DC)	Max ⁽²⁾ ETop (V-μSec)		Through Hole	Surface Mount
PE-53801	PE-53801S	LM259X-L1	259	0.13	23.1	3.4	LP-25	LCI-20
PE-53802	PE-53802S	LM259X-L2	178	0.16	16.5	2.8	LP-25	LCI-20
PE-53803	PE-53803S	LM259X-L3	118	0.2	13.2	1.8	LP-25	LCI-20
PE-53804	PE-53804S	LM259X-L4	79	0.25	9.9	1.5	LP-25	LCI-20
PE-53805	PE-53805S	LM259X-L5	55	0.3	6.6	1.0	LP-25	LCI-20
PE-53806	PE-53806S	LM259X-L6	39	0.34	6.6	.80	LP-25	LCI-20
PE-53807	PE-53807S	LM259X-L7	26	0.45	6.6	.62	LP-25	LCI-20
PE-53808	PE-53808S	LM259X-L8	374	0.2	75.9	2.7	LP-30	LCI-30
PE-53809	PE-53809S	LM259X-L9	256	0.25	33	2.2	LP-30	LCI-30
PE-53810	PE-53810S	LM259X-L10	176	0.3	26.4	1.4	LP-30	LCI-30
PE-53811	PE-53811S	LM259X-L11	118	0.38	19.8	1.2	LP-30	LCI-30
PE-53812	PE-53812S	LM259X-L12	78	0.46	16.5	0.8	LP-30	LCI-30
PE-53813	PE-53813S	LM259X-L13	55	0.56	13.2	0.5	LP-30	LCI-30
PE-53814	PE-53814S	LM259X-L14	39	0.68	9.9	0.3	LP-30	LCI-30
PE-53815	PE-53815S	LM259X-L15	26	0.84	6.6	0.2	LP-30	LCI-30
PE-53816	PE-53816S	LM259X-L16	17	1.02	6.6	0.1	LP-30	LCI-30
PE-53817	PE-53817S	LM259X-L17	375	0.36	75.9	1.3	LP-37	LCI-37
PE-53818	PE-53818S	LM259X-L18	252	0.44	49.5	0.9	LP-37	LCI-37
PE-53819	PE-53819S	LM259X-L19	173	0.54	36.3	0.6	LP-37	LCI-37
PE-53820	PE-53820S	LM259X-L20	115	0.67	29.7	0.4	LP-37	LCI-37
PE-53821	PE-53821S	LM259X-L21	78	0.82	23.1	0.3	LP-37	LCI-37
PE-53822	PE-53822S	LM259X-L22	54	1.0	16.5	0.2	LP-37	LCI-37
PE-53823	PE-53823S	LM259X-L23	38	1.2	13.2	0.1	LP-37	LCI-37
PE-53824	PE-53824S	LM259X-L24	26	1.48	9.9	0.1	LP-37	LCI-37
PE-53825	PE-53825S	LM259X-L25	18	1.81	9.9	0.06	LP-37	LCI-37
PE-53826	PE-53826S	LM259X-L26	377	0.68	75.9	1.0	LP-44	LCI-44
PE-53827	PE-53827S	LM259X-L27	248	0.83	72.6	0.6	LP-44	LCI-44
PE-53828	PE-53828S	LM259X-L28	168	1.02	56.1	0.4	LP-44	LCI-44
PE-53829	PE-53829S	LM259X-L29	112	1.26	42.9	0.3	LP-44	LCI-44
PE-53830	PE-53830S	LM259X-L30	77	1.54	33	0.2	LP-44	LCI-44
PE-53831	PE-53831S	LM259X-L31	53	1.87	26.4	0.13	LP-44	LCI-44
PE-53932	PE-53932S	LM259X-L32	37	2.24	19.8	0.10	LP-44	LCI-44
PE-53933	PE-53933S	LM259X-L33	24	2.74	16.5	0.07	LP-44	LCI-44
PE-53934	PE-53934S	LM259X-L34	17	3.0	13.2	0.05	KM-10	LCI-44
PE-53935	PE-53935S	LM259X-L35	250	1.5	72.6	0.23	KM-30	HCI-68
PE-54036	PE-54036S	LM259X-L36	168	1.81	75.9	0.18	KM-30	HCI-68
PE-54037	PE-54037S	LM259X-L37	114	2.22	62.7	0.10	KM-30	HCI-68
PE-54038	PE-54038S	LM259X-L38	77	2.7	52.8	0.09	KM-30	HCI-68
PE-54039	PE-54039S	LM259X-L39	53	3.0	42.9	0.08	KM-30	HCI-68
PE-54040	PE-54040S	LM259X-L40	38	3.0	29.7	0.05	KM-30	HCI-68
PE-54041	PE-54041S	LM259X-L41	25	3.0	19.8	0.04	KM-20	LCI-50
PE-54042	—	LM259X-L42	167	2.5	75.9	0.14	KM-40	—
PE-54043	—	LM259X-L43	110	3.0	75.9	0.09	KM-40	—
PE-54044	PE-54044S	LM259X-L44	77	3.0	59.4	0.08	KM-30	HCI-68
PE-53900	—	LM258X-L	19	4.5	32 ⁽³⁾	0.02	KM-30	—

Notes : 1. Inductance values may vary ±20%.
2. ETop rated at 150 KHz except where designated.

3. ETop rated at 100 KHz.
4. SIMPLE SWITCHER™ is a trademark of National Semiconductor Corporation.

12220 WORLD TRADE DRIVE, SAN DIEGO, CALIFORNIA 92128 • TEL 619-674-8100 • FAX 619-674-8262 • <http://www.pulseeng.com>

INDUCTORS DESIGNED FOR NATIONAL'S 150 KHz SIMPLE SWITCHER™



Mechanicals

LP Series

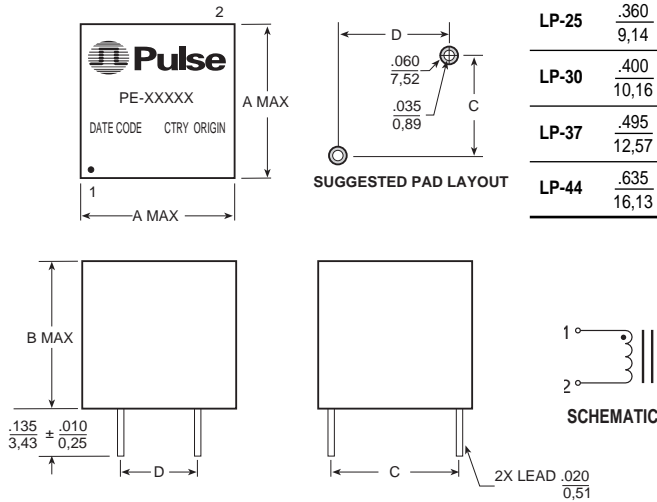

PKG	A	B	C	D
LP-25	$\frac{.360}{9,14}$	$\frac{.310}{7,87}$	$\frac{.250}{6,35}$	$\frac{.250}{6,35}$
LP-30	$\frac{.400}{10,16}$	$\frac{.300}{7,62}$	$\frac{.300}{7,62}$	$\frac{.300}{7,62}$
LP-37	$\frac{.495}{12,57}$	$\frac{.375}{9,52}$	$\frac{.375}{9,52}$	$\frac{.375}{9,52}$
LP-44	$\frac{.635}{16,13}$	$\frac{.365}{9,27}$	$\frac{.500}{12,7}$	$\frac{.300}{7,62}$

KM Series

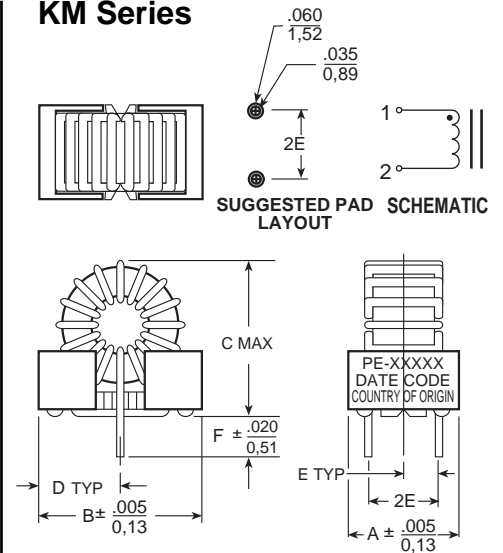

Package	A	B	C	D	E	F
KM-10	$\frac{.340}{8,64}$	$\frac{.580}{14,73}$	$\frac{.650}{16,51}$	$\frac{.290}{7,37}$	$\frac{.110}{2,79}$	$\frac{.130}{3,30}$
KM-20	$\frac{.450}{11,43}$	$\frac{.650}{16,51}$	$\frac{.700}{17,73}$	$\frac{.325}{8,26}$	$\frac{.150}{3,81}$	$\frac{.130}{3,30}$
KM-30	$\frac{.450}{11,43}$	$\frac{.830}{21,08}$	$\frac{.950}{24,13}$	$\frac{.415}{10,54}$	$\frac{.150}{3,81}$	$\frac{.130}{3,30}$
KM-40	$\frac{.600}{15,24}$	$\frac{.950}{24,13}$	$\frac{1,00}{25,4}$	$\frac{.475}{12,07}$	$\frac{.225}{5,72}$	$\frac{.130}{3,30}$

LCI Series

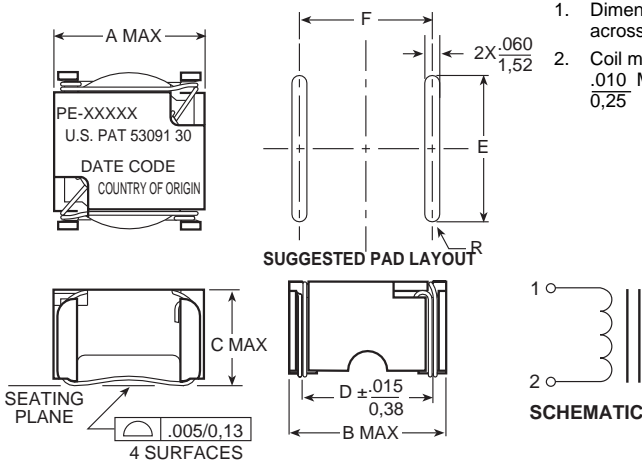

Notes:

1. Dimension "D" is measured across terminal blocks only.
2. Coil must clear seating plane by $\frac{.010}{0,25}$ MIN.

PKG	A	B	C	D	E	F
LCI-20	$\frac{.340}{8,64}$	$\frac{.340}{8,64}$	$\frac{.270}{6,86}$	$\frac{.260}{6,60}$	$\frac{.300}{7,62}$	$\frac{.270}{6,86}$
LCI-30	$\frac{.435}{11,05}$	$\frac{.440}{11,18}$	$\frac{.360}{9,14}$	$\frac{.350}{8,89}$	$\frac{.400}{10,16}$	$\frac{.360}{9,14}$
LCI-37	$\frac{.565}{14,35}$	$\frac{.570}{14,48}$	$\frac{.360}{9,14}$	$\frac{.450}{11,43}$	$\frac{.520}{13,21}$	$\frac{.460}{11,68}$
LCI-44	$\frac{.600}{15,24}$	$\frac{.620}{15,75}$	$\frac{.390}{9,91}$	$\frac{.500}{12,7}$	$\frac{.550}{13,97}$	$\frac{.510}{12,95}$
LCI-50	$\frac{.670}{17,02}$	$\frac{.700}{17,78}$	$\frac{.390}{9,91}$	$\frac{.580}{14,73}$	$\frac{.620}{15,75}$	$\frac{.590}{14,99}$

HCI-68

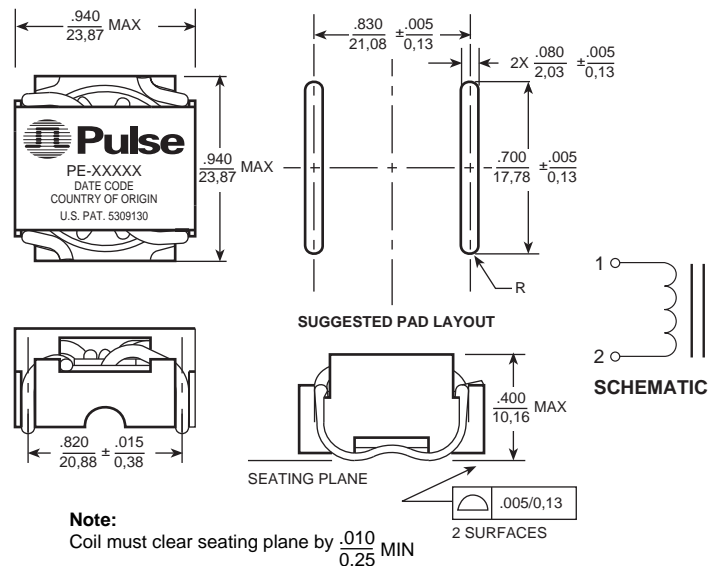

Note:



Coil must clear seating plane by $\frac{.010}{0,25}$ MIN

Dimensions: $\frac{\text{Inches}}{\text{mm}}$

Unless otherwise specified, all tolerances are $\pm \frac{.010}{0,25}$

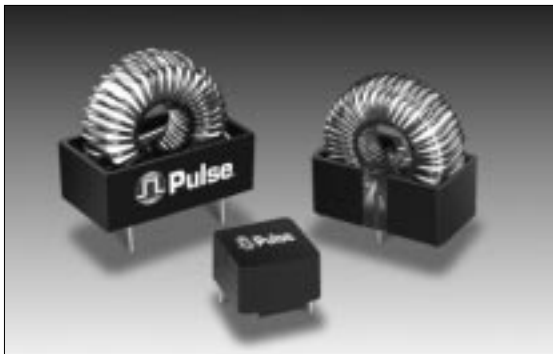
INDUCTORS DESIGNED FOR NATIONAL'S 50 KHz SIMPLE SWITCHER™



- 
 Designed for use with National's device numbers LM2574/LM2575/LM2576
- 
 Base material meets flammability requirements of UL 94V-0
- 
 Performance verified by National Semiconductor

Electrical Specifications @ 25°C— Operating Temperature -30° to +130° C

Part Identification		Reference Operating Values ⁽¹⁾			Design Control Values			
Pulse Part Number	Inductor Code	Inductance Typical (μHy)	I _{DC} (Amps)	ET _{OP} (V-μSec)	Inductance No DC ⁽²⁾ (μHy ± 20%)	DCR (Ω MAX)	Package Style	Lead Diameter
PE-53112	L47	47	3.0	90	38	0.05	KM-2.0	.025
PE-92114K	L68	68	3.0	90	55	0.02	KM-4.0	.040
PE-92108K	L100	100	3.0	90	91	0.04	KM-4.0	.032
PE-53113	L150	150	2.0	90	130	0.10	KM-4.0	.025
PE-52626	L220	220	1.4	90	230	0.38	Low Profile	.025 SQ.
PE-53145	L220	220	1.4	90	176	0.14	KM-3.0	.020
PE-52627	L330	330	0.9	90	302	0.74	Low Profile	.025 SQ.
PE-53146	L330	330	0.9	90	267	0.18	KM-3.0	.020
PE-53114	L470	470	0.64	90	426	0.16	KM-4.0	.025
PE-52629	L680	680	.85	90	657	1.25	Low Profile	.025 SQ.
PE-53115	H150	150	3.0	200	136	0.10	KM-4.0	.025
PE-53116	H220	220	3.0	200	167	0.07	KM-5.0	.032
PE-53117	H330	330	3.0	200	292	0.15	KM-5.0	.025
PE-53118	H470	470	2.0	200	369	0.17	KM-5.0	.025
PE-53119	H680	680	1.3	200	562	0.20	KM-5.0	.025
PE-53120	H1000	1000	0.95	200	762	0.24	KM-5.0	.025
PE-53121	H1500	1500	0.62	200	1150	1.00	Case	.032
PE-53122	H220	2200	0.42	200	1730	1.80	Case	.032

Notes:

1. Typical inductance occurs at the I_{DC} and ET_{OP} values shown.
2. The control value of inductance is measured at B_{OP} equal to or less than 10 gauss (10 mV @ 20 KHz) without DC current.
3. Inductance decreases with higher values of DC current and increases with lower values of DC current.
4. Inductance increases with increase in B_{OP} or ET_{OP}.
5. SIMPLE SWITCHER™ is a trademark of National Semiconductor Corporation.

INDUCTORS DESIGNED FOR NATIONAL'S 50 KHz SIMPLE SWITCHER™



Mechanicals

Low Profile Series

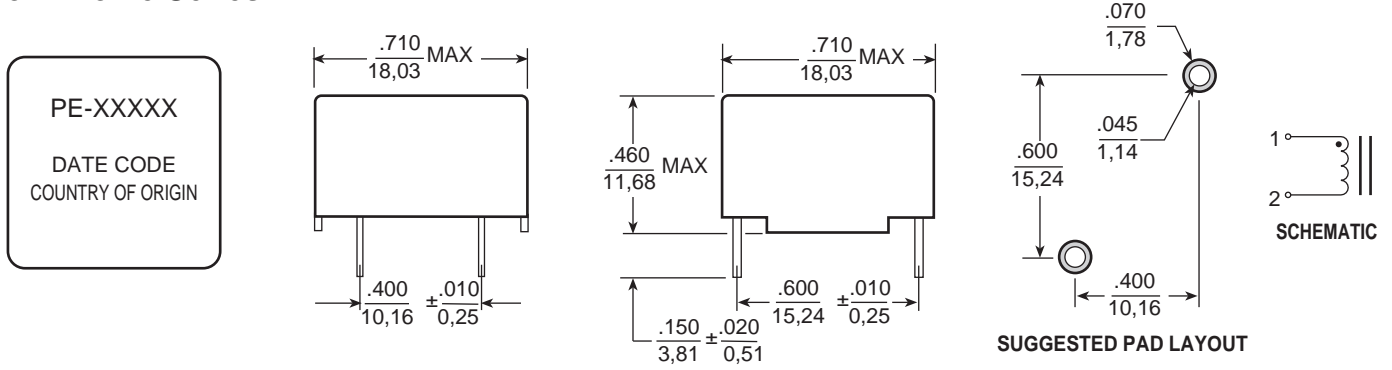

Case Series

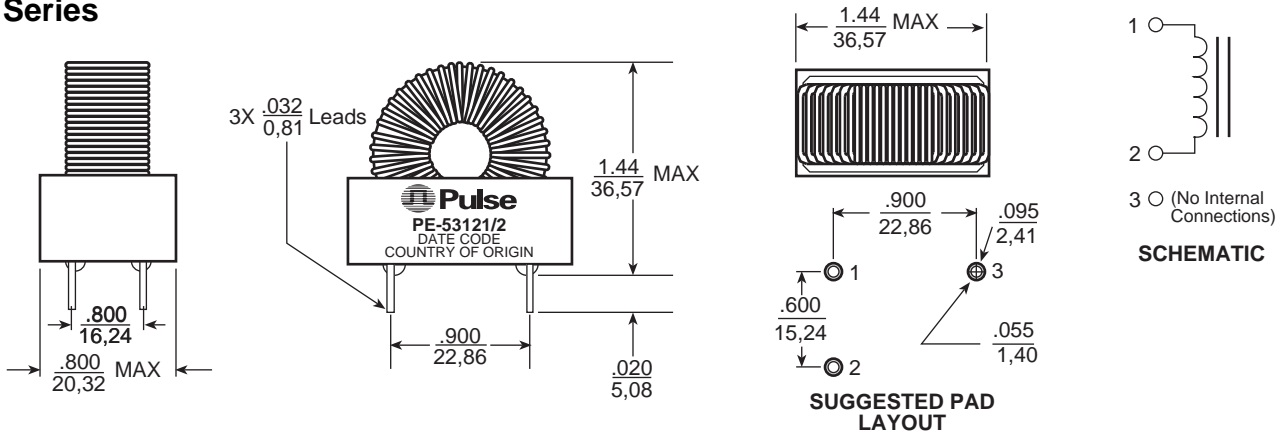

KlipMount Series

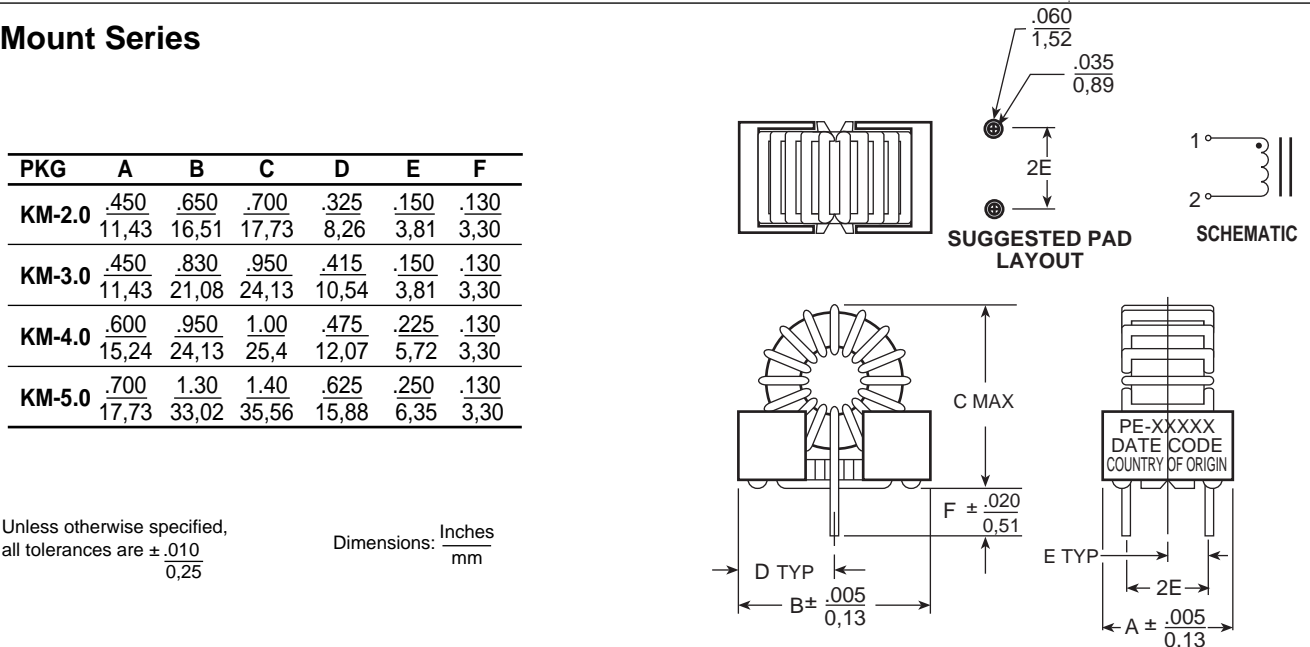





Unless otherwise specified,
all tolerances are ±.010
0,25

Dimensions: Inches
mm

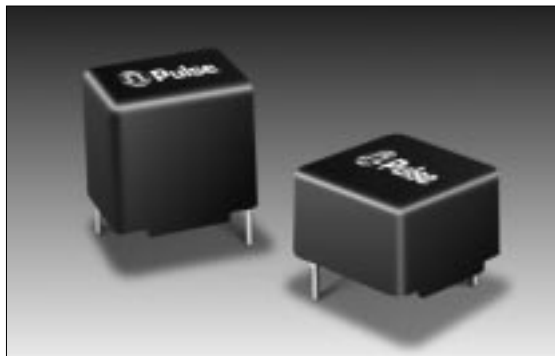
STANDARD LOW POWER INDUCTORS

Designed for General Purpose Use — Switch Mode Power Converters and Ripple Filters



-  High inductance stability with varying volt-seconds and load currents
-  Compact, standard packages
-  Low profile or vertical packages

Electrical Specifications @ 25°C — Operating Temperature -30°C to 130°C

REFERENCE OPERATING VALUES						DESIGN CONTROL VALUES		
Low Profile Part Number	Vertical Part Number	Inductance Typical (μHy)	I _{DC} (AMPS) ⁽¹⁾	Maximum E _{TOP} ⁽²⁾ (V-μSec)	Energy Storage (μJ) ⁽¹⁾	Inductance No DC (μHy ± 20%)	20 KHz Test mV No DC	DCR (Ω MAX)
PE-52625	PE-52645	150	1.7	80	215	145	110	.42
PE-52626	PE-52646	220	1.5	90	240	226	140	.42
PE-52627	PE-52647	330	1.0	100	165	316	170	.78
PE-52628	PE-52648	470	.90	120	190	480	210	1.26
PE-52629	PE-52649	680	.85	175	245	690	250	1.50
PE-52630	PE-52650	820	.75	175	230	780	270	2.40
PE-52631	PE-52651	1000	.50	175	125	975	300	2.60

NOTES: 1. I_{DC} rated for 40°C Temperature rise @ low E_{TOP}. 2. Derate current 20% at this E_{TOP}.

Mechanicals

Low Profile Package

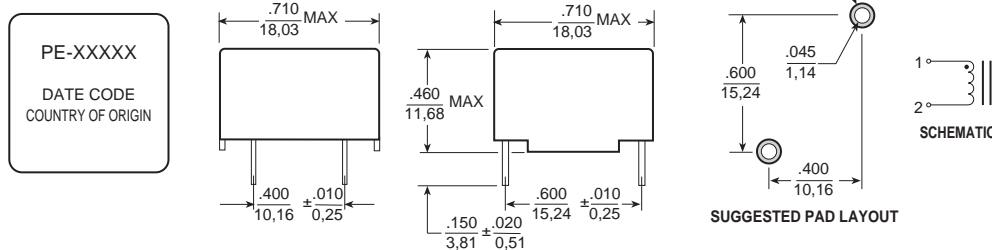

Vertical Package

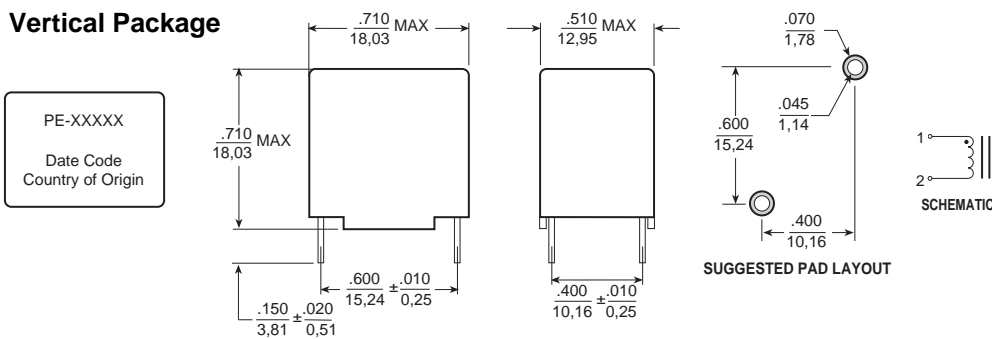

Unless otherwise specified, all tolerances are ± .010 / 0,25 inches / mm

Inductance Characteristics

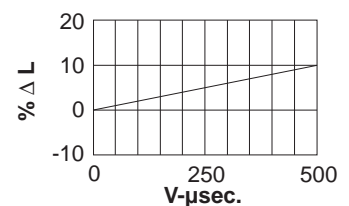

Inductance Variance vs. E.T.

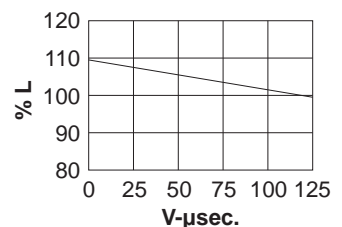



Inductance Variance vs. Load Current

FLYBACK TRANSFORMERS

Designed for National's 100 KHz Simple Switcher™



-  Designed for use with National's device numbers LM2585/86 and LM2587/88
-  Surface mount
-  Performance verified by National Semiconductor

Electrical Specifications @ 25°C — Operating Temperature -30°C to 130°C

Pulse Part Number	L _P (μHy NOM)	I _{IN} peak	V _{IN} (VDC)	V _{OUT 1} (VDC)	V _{OUT 2} (VDC)	V _{OUT 3} (VDC)	I _{OUT 1}	I _{OUT 2}	I _{OUT 3}	Turns Ratio	DCR Primary (Ω MAX)	DCR Sec 1 (Ω MAX)	DCR Sec 2 (Ω MAX)	DCR Sec 3 (Ω MAX)
PE-68411	22	4.85	4-6	3.3	—	—	1.8	—	—	1:1	0.04	0.04	—	—
			4-6	5	—	—	1.4	—	—					
			8-16	12	—	—	1.2	—	—					
PE-68412	22	5.00	4-6	12	-12	—	0.3	0.3	—	1:2.5:2.5	0.04	0.5	0.5	—
PE-68413	66	2.99	18-36	5	12	-12	1.8	0.25	0.25	1:0.5:1.15:1.15	0.30	0.04	0.80	0.80
PE-68414	65	2.98	18-36	12	-12	—	0.63	0.63	—	1:1.2:1.2	0.055	0.25	0.25	—
PE-68421	85	4.90	18-36	12	-12	—	1	1	—	1:0.8:0.8	0.12	0.22	0.22	—
PE-68422	85	4.92	18-36	5	12	-12	2.5	0.5	0.5	1:0.35:0.8:0.8	0.14	0.025	0.25	0.25

Mechanicals

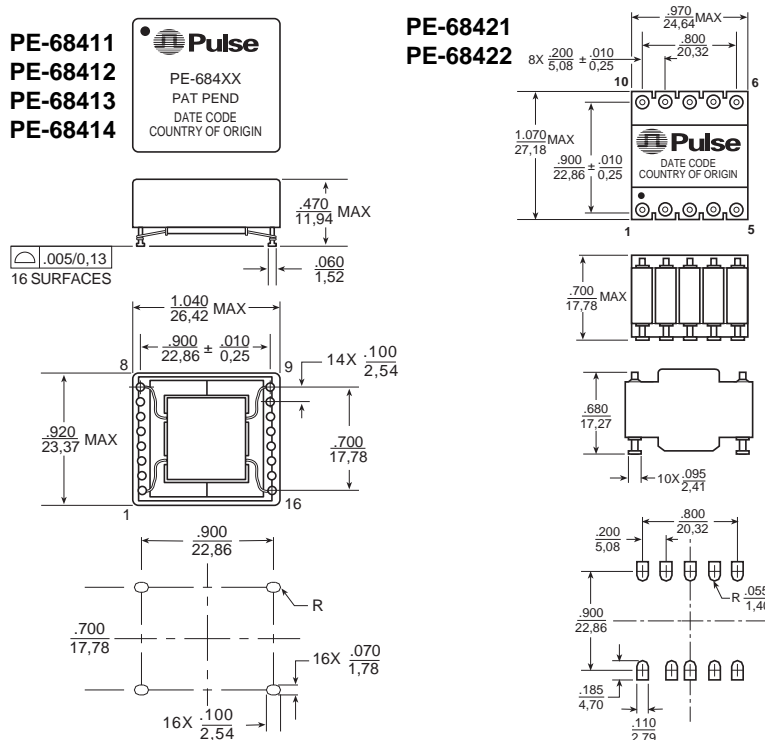

Unless otherwise specified, all tolerances are ± $\frac{.010}{.025}$ Dimensions: $\frac{\text{inches}}{\text{mm}}$

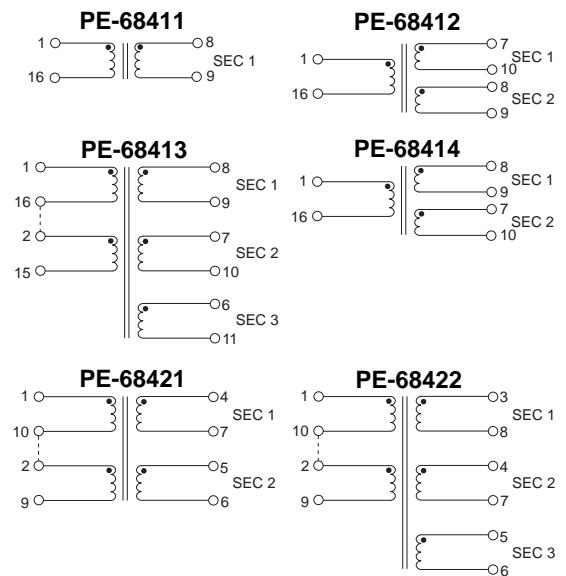

Schematics

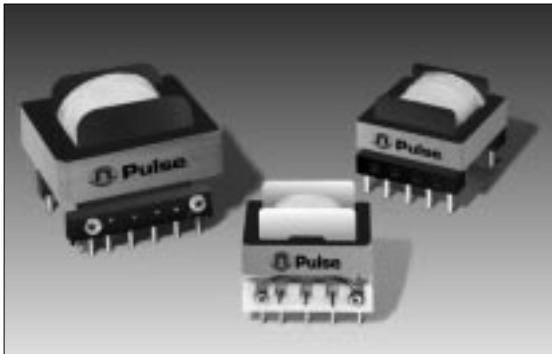

FLYBACK TRANSFORMERS

Designed for National's 52 KHz Simple Switcher™



-  Designed for use with National's device numbers LM1577/LM2577
-  Base material meets flammability requirements of UL 94V-0
-  Performance verified by National Semiconductor

Electrical Specifications @ 25°C — Operating Temperature -30°C to 130°C

Part Number	Turns Ratio (± 3%)	Primary Inductance (± 10% μH)	Leakage Inductance (μH MAX)	PRI DCR (Ω MAX)	SEC DCR (Ω MAX)	Hipot
PE-65300	1:2 CT	100	1	.058	.450	600
PE-65301	1:1 CT	200	5	.075	.380	600
PE-65302	1:1 CT	400	10	.155	.260	600

Mechanicals

PE-65300

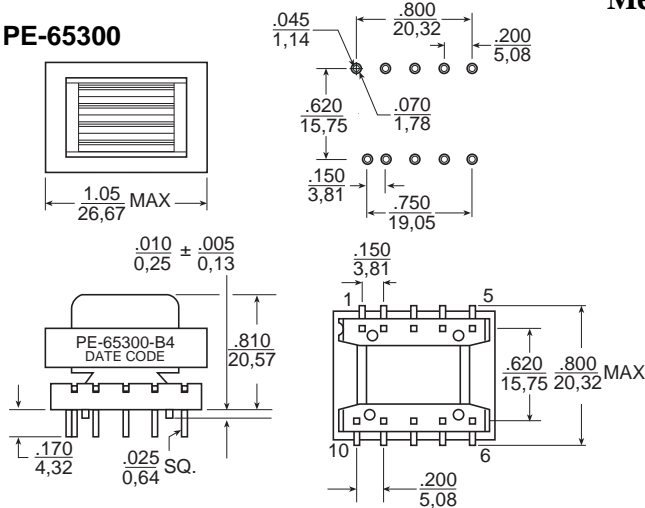

PE-65301

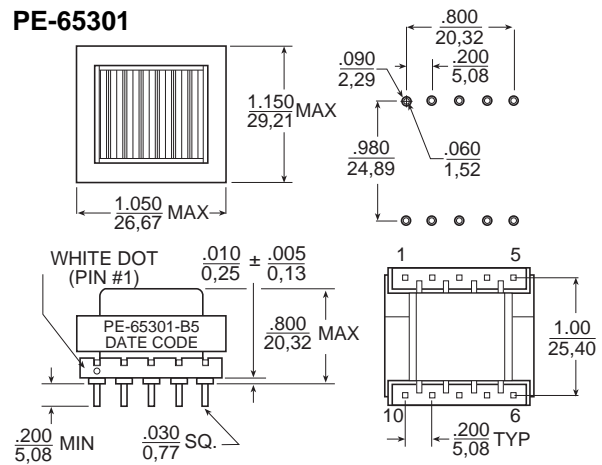

PE-65302

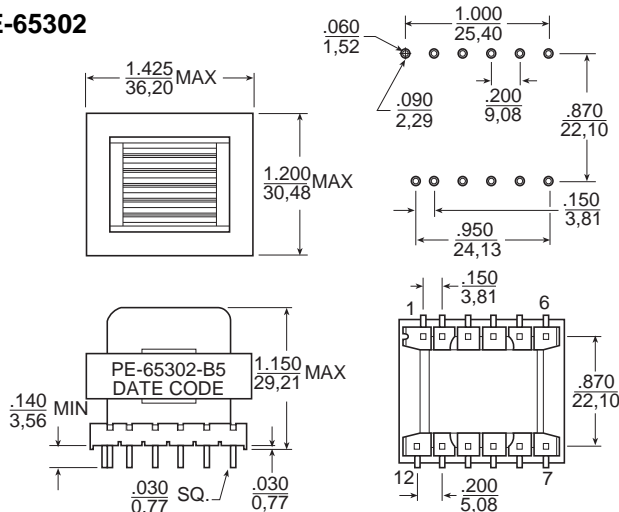

Schematics

PE-65300 & PE-65301

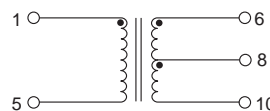

PE-65302

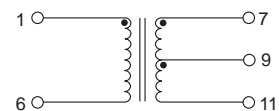

Unless otherwise specified, all tolerances are ± .010 / 0,25

Dimensions: Inches / mm

WEIGHT AND PAN SIZE INFORMATION

For Simple Switcher™ Magnetics



By Part Number

Part Number	Weight in Grams	Pan Size		Page Number	Part Number	Weight in Grams	Pan Size		Page Number
		Per Tube	Tray				Per Tube	Tray	
PE-52625	10	25	—	6	PE-53819	3	40	—	2
PE-52626	11	25	—	4, 6	PE-53819S	3	30	—	2
PE-52627	11	25	—	4, 6	PE-53820	3	40	—	2
PE-52628	11	25	—	6	PE-53820S	3	30	—	2
PE-52629	11	25	—	4, 6	PE-53821	3	40	—	2
PE-52630	11	25	—	6	PE-53821S	3	30	—	2
PE-52631	9	25	—	6	PE-53822	3	40	—	2
PE-52645	9	40	—	6	PE-53822S	3	30	—	2
PE-52646	10	40	—	6	PE-53823	3	50	—	2
PE-52647	10	40	—	6	PE-53823S	3	30	—	2
PE-52648	9	40	—	6	PE-53824	3	50	—	2
PE-52649	9	40	—	6	PE-53824S	3	35	—	2
PE-52650	9	40	—	6	PE-53825	3	40	—	2
PE-52651	9	40	—	6	PE-53825S	3	30	—	2
PE-53112	6	30	—	4	PE-53826	7	45	—	2
PE-53113	19	—	20	4	PE-53826S	3	35	—	2
PE-53114	22	—	30	4	PE-53827	6	45	—	2
PE-53115	19	—	15	4	PE-53827S	3	35	—	2
PE-53116	47	—	15	4	PE-53828	9	45	—	2
PE-53117	40	—	36	4	PE-53828S	4	35	—	2
PE-53118	43	—	36	4	PE-53829	6	30	—	2
PE-53119	44	—	36	4	PE-53829S	3	35	—	2
PE-53120	45	—	15	4	PE-53830	7	45	—	2
PE-53121	53	—	75	4	PE-53830S	3	35	—	2
PE-53122	53	—	25	4	PE-53831	7	45	—	2
PE-53145	12	20	—	4	PE-53831S	4	35	—	2
PE-53146	12	20	—	4	PE-53900	12	20	—	2
PE-53801	2	50	—	2	PE-53932	7	45	—	2
PE-53801S	1	60	—	2	PE-53932S	3	35	—	2
PE-53802	2	50	—	2	PE-53933	6	45	—	2
PE-53802S	1	60	—	2	PE-53933S	3	35	—	2
PE-53803	2	50	—	2	PE-53934	4	100	—	2
PE-53803S	1	60	—	2	PE-53934S	3	35	—	2
PE-53804	2	50	—	2	PE-53935	11	20	—	2
PE-53804S	1	60	—	2	PE-53935S	10	20	—	2
PE-53805	2	50	—	2	PE-54036	10	20	—	2
PE-53805S	1	60	—	2	PE-54036S	10	20	—	2
PE-53806	2	50	—	2	PE-54037	10	20	—	2
PE-53806S	1	60	—	2	PE-54037S	10	20	—	2
PE-53807	2	50	—	2	PE-54038	10	20	—	2
PE-53807S	1	60	—	2	PE-54038S	11	20	—	2
PE-53808	2	50	—	2	PE-54039	8	20	—	2
PE-53808S	2	30	—	2	PE-54039S	10	20	—	2
PE-53809	2	50	—	2	PE-54040	8	20	—	2
PE-53809S	2	45	—	2	PE-54040S	10	20	—	2
PE-53810	2	50	—	2	PE-54041	5	30	—	2
PE-53810S	2	45	—	2	PE-54041S	5	30	—	2
PE-53811	2	50	—	2	PE-54042	17	20	—	2
PE-53811S	2	45	—	2	PE-54043	17	20	—	2
PE-53812	2	50	—	2	PE-54044	12	20	—	2
PE-53812S	2	45	—	2	PE-54044S	11	20	—	2
PE-53813	2	50	—	2	PE-65300	18	80	—	8
PE-53813S	2	45	—	2	PE-65301	34	80	—	8
PE-53814	2	50	—	2	PE-65302	51	80	—	8
PE-53814S	2	45	—	2	PE-68411	14	—	30	7
PE-53815	2	50	—	2	PE-68412	14	—	30	7
PE-53815S	2	45	—	2	PE-68413	14	—	30	7
PE-53816	2	45	—	2	PE-68414	14	—	30	7
PE-53816S	2	45	—	2	PE-68421	21	—	35	7
PE-53817	3	40	—	2	PE-68422	24	—	35	7
PE-53817S	3	30	—	2	PE-92108K	19	—	20	4
PE-53818	3	50	—	2	PE-92114K	22	20	—	4
PE-53818S	3	30	—	2					

For More Information :

Corporate

12220 World Trade Drive
San Diego, CA 92128
Tel: 619 674 8100
FAX: 619 674 8262
<http://www.pulseeng.com>
Quick-Facts: 619 674 9672

Europe

Millpool House
Mill Lane, Godalming
Surrey GU7 1EY
U.K.
Tel: 441 483 428 877
FAX: 441 483 416 011

Asia

P.O. Box 26-11, KEPZ
6 Central Sixth Road
KEPZ, Kaohsiung
Taiwan, R.O.C.
Tel: 886 7 821 3141
FAX: 886 7 841 9707

Distributor

Performance warranty of products offered on this data sheet is limited to the parameters specified. Data is subject to change without notice. Simple Switcher™ is a trademark of National Semiconductor Corporation. Other brand and product names mentioned herein may be trademarks or registered trademarks of their respective owners.