







-  Available in vertical, low profile and *KlipMount™*
-  SMPS averaging filter
-  Characterized for general purpose use and ripple filters
-  Single-layer designs
-  Can be used as differential mode inductors in EMI filters³

Electrical Specifications @ 25°C — Operating Temperature -30°C to 130°C

REFERENCE OPERATING VALUES						DESIGN CONTROL VALUES					
Vertical Part Number	Low Profile Part Number	Inductance Typical (μH) ¹	I _{DC} (AMPS)	ET _{TOP} (V-μSec)	Energy Storage (μJ) ⁴	Inductance No DC (μHy) ±20%	20 KHz Test mV No DC ²	DCR (Ω MAX) ⁶	Coil Size Code	Klip Mount Package*	Lead Diameter (In) ±.003
PE-51591	PE-92421	20	2.0	52	40	32.8	33	.060	H	—	.020
PE-92100	—	25	2.6	30	85	20.7	22	.043	A	KM1	.020
PE-92101	PE-92401	50	2.6	50	169	45.7	45	.071	B	KM2	.020
PE-92102	PE-92402	100	2.6	90	338	94.1	90	.100	C	KM3	.020
PE-92103	—	35	2.6	55	118	28.4	36	.037	B	KM2	.025
PE-92104	PE-92404	70	3.0	85	315	61.0	73	.052	C	KM3	.025
PE-92105	PE-92405	145	3.0	140	653	141.8	140	.087	D	KM4	.025
PE-92106	—	285	3.0	300	1283	264.1	340	.140	E	KM5	.025
PE-92107	—	450	3.0	425	2025	436.3	500	.200	F	—	.025
PE-92108	PE-92408	100	3.6	130	648	90.7	110	.045	D	KM4	.032
PE-92109	—	165	4.0	240	1320	152.0	260	.070	E	KM5	.032
PE-92110	—	270	4.0	350	2160	263.9	400	.100	F	—	.032
PE-92111	—	40	4.0	70	320	37.9	57	.027	C	KM3	.032
PE-51590	PE-92420	22	5.0	44	275	20.3	37	.020	G	—	.032
PE-92112	PE-92412	100	5.0	200	1250	90.7	180	.034	E	KM5	.042
PE-92113	—	170	5.0	300	2125	159.7	310	.050	F	—	.042
PE-92114	PE-92414	55	5.0	100	688	54.9	88	.023	D	KM4	.042
PE-92115	—	95	7.0	225	2328	96.0	200	.025	F	—	.051
PE-92116	PE-92416	55	7.0	150	1348	49.1	100	.017	E	KM5	.051
PE-92117	—	55	10.0	175	2750	55.9	120	.013	F	—	.064

*Parts available with *KlipMount* option can be ordered by adding a "K" suffix to the part number (i.e. PE-92100K).

Relationships Between Reference and Operating Conditions

Inductance vs. DC Current
(at reference ET)

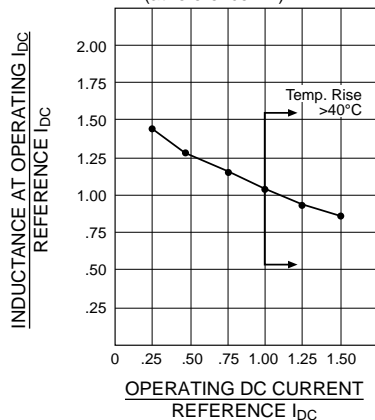

Inductance vs. Operating ET
(at reference I_{DC})

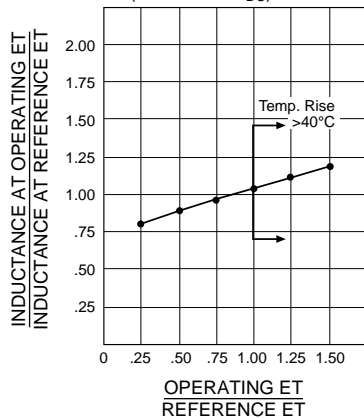

Max. Operating ET vs. Frequency
(at reference I_{DC})

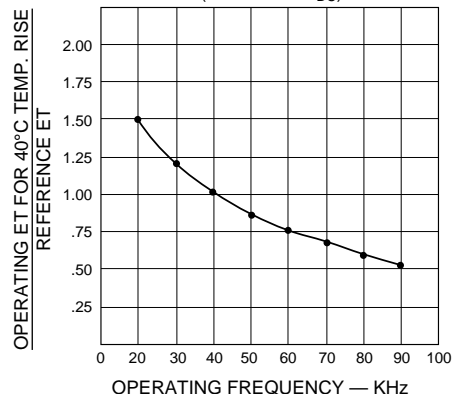

LOW COST INDUCTORS

Mechanical Information



Mechanicals

- Base material meets flammability requirements of UL 94V-0
- Mechanically rigid mount
- PC board — automatic insertability
- Lowest cost

Standard Package	A	B	C	D	E
	Nom. ± .005	Nom.	Typical		
KM-1	$\frac{.340}{8,64}$	$\frac{.580}{14,73}$	$\frac{.650}{16,57}$	$\frac{.29}{7,37}$	$\frac{.110}{2,79}$
KM-2	$\frac{.450}{11,43}$	$\frac{.650}{16,51}$	$\frac{.700}{17,78}$	$\frac{.325}{8,26}$	$\frac{.150}{3,91}$
KM-3	$\frac{.450}{11,73}$	$\frac{.830}{21,03}$	$\frac{.950}{24,13}$	$\frac{.415}{10,54}$	$\frac{.150}{3,91}$
KM-4	$\frac{.600}{15,24}$	$\frac{.950}{24,13}$	$\frac{1.10}{27,94}$	$\frac{.475}{12,07}$	$\frac{.225}{5,72}$
KM-5	$\frac{.700}{17,78}$	$\frac{1.3}{33,02}$	$\frac{1.40}{35,56}$	$\frac{.625}{15,88}$	$\frac{.250}{6,35}$

Note: Units with large wire sizes may exceed B dimension.
 KLIPMOUNT™ is a trademark of Pulse Engineering, Inc.

Dimensions: $\frac{\text{Inches}}{\text{mm}}$

Unless otherwise specified, all tolerances are $\pm \frac{.010}{0,25}$

KlipMount™ Package

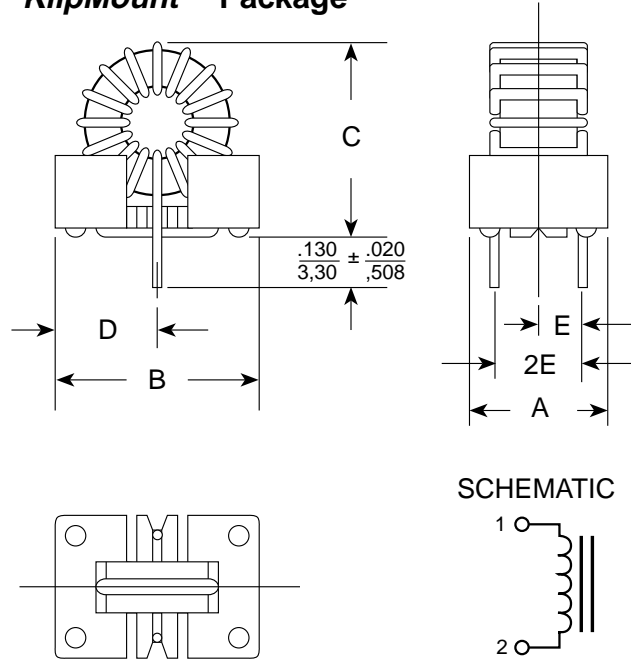

Coil Size	P (MAX)	N (MAX)	L (+.125/-.025)	M	K
A	$\frac{0.55}{13,97}$	$\frac{0.25}{6,35}$	$\frac{.375}{9,53}$	$\frac{.180}{4,57}$	—
B	$\frac{0.70}{17,78}$	$\frac{0.38}{9,65}$	$\frac{.375}{9,53}$	$\frac{.280}{7,11}$	$\frac{.530}{13,46} \pm \frac{.050}{1,27}$
C	$\frac{0.85}{21,59}$	$\frac{0.41}{10,41}$	$\frac{.375}{9,53}$	$\frac{.280}{7,11}$	$\frac{.720}{18,29} \pm \frac{.050}{1,27}$
D	$\frac{1.05}{26,27}$	$\frac{0.55}{13,97}$	$\frac{.375}{9,53}$	$\frac{.400}{10,16}$	$\frac{.840}{21,24} \pm \frac{.020}{,51}$
E	$\frac{1.40}{35,56}$	$\frac{0.700}{17,78}$	$\frac{.375}{9,53}$	$\frac{.500}{12,7}$	$\frac{1.10}{25,65} \pm \frac{.100}{2,54}$
F	$\frac{1.65}{41,91}$	$\frac{0.700}{17,78}$	$\frac{.375}{9,53}$	$\frac{.500}{12,7}$	—
G	$\frac{0.85}{21,59}$	$\frac{0.33}{8,38}$	$\frac{.875}{22,23}$	—	$\frac{.730}{18,29} \pm \frac{.05}{1,27}$
H	$\frac{0.64}{16,26}$	$\frac{0.28}{7,11}$	$\frac{.875}{22,23}$	—	$\frac{.530}{13,46} \pm \frac{.05}{1,27}$

Vertical Package

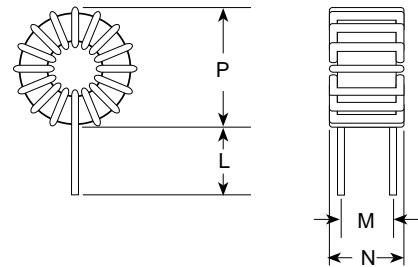

Low Profile Package

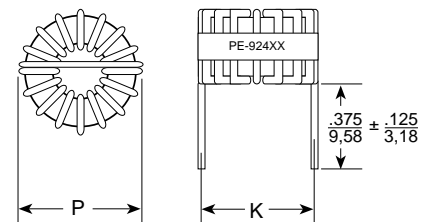

NOTES:

1. Typical Inductance occurs at I_{DC} and E_{TOP} values shown.
2. Design control test voltage critical. Inductance increases with voltage.
3. For line filter applications RMS line current is limited to specified reference DC Current.
4. $\frac{LI^2}{2}$ rating is the ability of the inductor to store energy.
5. Leads stripped and tinned to within .06" of Coil.
6. DCR for vertical part measured close to coil. Add 10% more for Low Profile part.