

# ZERO-DIVISORS AND THEIR GRAPH LANGUAGES

HARLEY D. EADES III

ABSTRACT. We introduce the use of formal languages in place of zero-divisor graphs used to study theoretic properties of commutative rings. We show that a regular language called a graph language can be constructed from the set of zero-divisors of a commutative ring. We then prove that graph languages are equivalent to their associated graphs. We go on to define several properties of graph languages.

## 1. INTRODUCTION

This article introduces the use of formal languages in place of zero-divisor graphs of a commutative ring with unity. We are interested mainly in whether we can define formal languages which provide the same information as zero-divisor graphs and what type of formal languages we obtain. In section two we primarily discuss how to obtain a formal language from the set of nonzero zero-divisors, and we show that it is regular. The remaining section deals with some interesting properties of graph languages.

We define several basic notions from commutative ring theory and formal language theory that are used throughout this article. Let  $R$  be a commutative ring with unity and  $Z(R)$  be the set of zero-divisors of  $R$ . We define a simple graph  $\Gamma(R)$ , called the zero-divisor graph of  $R$ , with vertex set  $Z(R)^* = Z(R) - 0$ , and distinct  $z_1, z_2 \in Z(R)^*$  are adjacent if and only if  $z_1 z_2 = 0$ . For example,  $\Gamma(R)$  is the empty graph if and only if  $R$  is an integral domain [5]. Lets consider a short example.

**Example 1.1.** *Let  $R = \mathbb{Z}_2 \times \mathbb{Z}_2 \times \mathbb{Z}_2$ . Then  $Z(R)^* = \{(1, 0, 1), (0, 0, 1), (0, 1, 0), (1, 0, 0), (1, 1, 0), (0, 1, 1)\}$ . Using this set of zero-divisors we obtain the zero-divisor graph of  $R$  depicted below.*

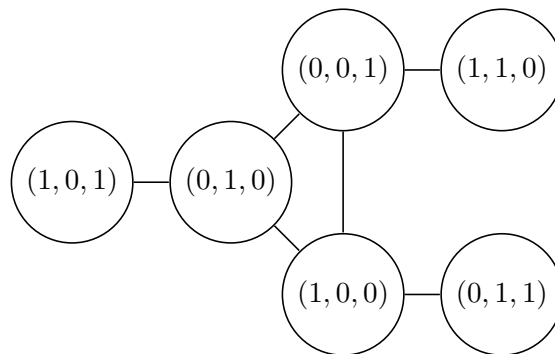

Let  $\Sigma$  be a set of symbols, called an alphabet, and  $\Sigma^*$  be the set of all possible concatenations of  $\Sigma$ . A *formal language* is a subset of  $\Sigma^*$ . A *deterministic finite acceptor (DFA)* is defined by the quintuple,  $M = (Q, \Sigma, \delta, q_0, F)$ , where  $Q$  is a finite set of *internal states*,  $\Sigma$  is a finite set of symbols called the *input alphabet*,  $\delta : Q \times \Sigma \rightarrow Q$  is the total function, called the *transition function*,  $q_0 \in Q$  is the *initial state*, and  $F \subseteq Q$  is a set of *final states*. Likewise, a *nondeterministic finite acceptor (NFA)* is defined by the quintuple,  $M = (Q, \Sigma, \delta, q_0, F)$  where  $Q, \Sigma, q_0,$  and  $F$  are as defined for deterministic finite acceptors, but  $\delta : Q \times (\Sigma \cup \lambda) \rightarrow 2^Q$ . We define  $S(M) = Q_M$  as the set of states of the finite automata  $M$ . Finally,  $DFA(M_{NFA}(R, z))$  and  $DFA(M_{NFA}(R))$  are the DFA's constructed using the subset construction algorithm found in [15, 20]. A language is *regular* when there exists a finite acceptor for it [15]. Before moving on we will now consider two examples illustrating the concepts discussed above.

**Example 1.2.** Let  $\Sigma = \{a, b, c\}$  and  $L = \{w \mid w \in \Sigma^* \text{ and } w = a^r b, \text{ where } r \text{ is an odd integer}\}$ . To show that  $L$  is regular we have to construct a finite automata which accepts all the words in  $L$ . There in fact does exist a DFA that accepts  $L$ . Let  $M = (\{q_0, q_1, q_2, q_3\}, \Sigma, \delta, q_0, \{q_2\})$ , where  $\delta$  is defined in the table below.

| $\delta$ | $a$   | $b$   |
|----------|-------|-------|
| $q_0$    | $q_1$ | $q_3$ |
| $q_1$    | $q_0$ | $q_2$ |
| $q_2$    | $q_3$ | $q_3$ |
| $q_3$    | $q_3$ | $q_3$ |

It is common to depict a finite automata as a transition diagram. The transition diagram for  $M$  is the following.

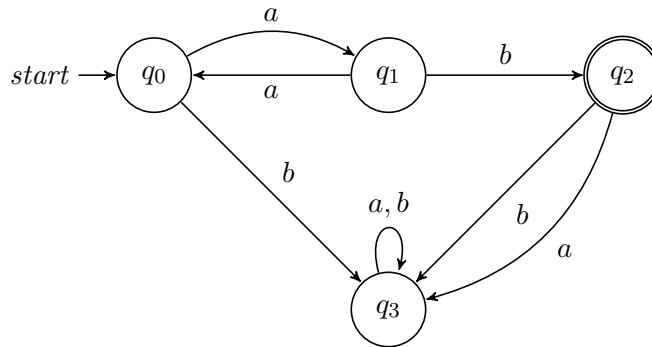

**Example 1.3.** Let  $\Sigma = \{a, b, c\}$  and  $L = \{w \mid w \in \Sigma^* \text{ and the fourth symbol from the last symbol in } w \text{ is } c\}$ . We construct a NFA accepting  $L$ . Let  $M = (\{q_0, q_1, q_2, q_3, q_4, q_5\}, \Sigma, \delta, q_0, \{q_4\})$ , where  $\delta$  is defined in the table below.

| $\delta$ | $a$       | $b$       | $c$            |
|----------|-----------|-----------|----------------|
| $q_0$    | $\{q_0\}$ | $\{q_0\}$ | $\{q_0, q_1\}$ |
| $q_1$    | $\{q_2\}$ | $\{q_2\}$ | $\{q_2\}$      |
| $q_2$    | $\{q_3\}$ | $\{q_3\}$ | $\{q_3\}$      |
| $q_3$    | $\{q_4\}$ | $\{q_4\}$ | $\{q_4\}$      |
| $q_4$    | $\{q_5\}$ | $\{q_5\}$ | $\{q_5\}$      |
| $q_5$    | $\{q_5\}$ | $\{q_5\}$ | $\{q_5\}$      |

The transition diagram for  $M$  is the following.

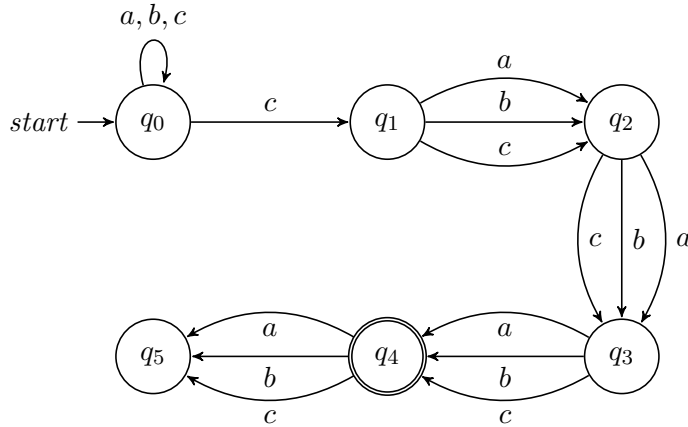

A grammar  $G$  is defined as a quadruple  $G = (V, T, S, P)$ , where  $V$  is a finite set of objects, called variables,  $T$  is a finite set of objects, called terminal symbols,  $S \in V$  is a special symbol, called the start variable, and  $P$  is a finite set of productions. A grammar  $G$  is said to be *regular* if all productions are of the form  $A \rightarrow xB$ ,  $A \rightarrow x$  or  $A \rightarrow Bx$ ,  $A \rightarrow x$  where  $A, B \in V$ , and  $x \in T^*$  [15]. A basic introduction to formal language theory can be found in [15, 20, 21], and an introduction to commutative ring theory and zero-divisor graphs can be found in [2, 3, 5, 6, 7, 8].

A word on notation is in order. The term ring should be read as commutative ring with unity; hence, we will implicitly assume that all rings are indeed commutative rings with unity which are not integral domains. We also abbreviate a formal language as simply a language. By subword we mean, that if  $u$  is a word in some language, then  $u$  is a *subword* if and only if there exists a word  $w = vuz$ , where  $v$  and  $z$  are words in the language [21].

## 2. OBTAINING A REGULAR GRAPH LANGUAGE

By definition, zero-divisor graphs of commutative rings are undirected. However, we will be converting directed graphs to formal languages, so we will need to be able to convert an undirected graph to a directed graph. To convert an undirected graph to a directed graph, simply replace all edges in the undirected graph with a directed edge. Then connect each vertex to all its adjacent vertices with directed edges. For example, in example 2.1 the

graph on the left is an undirected graph, and its equivalent directed graph obtained by following the previous algorithm is on the right.

**Example 2.1.**

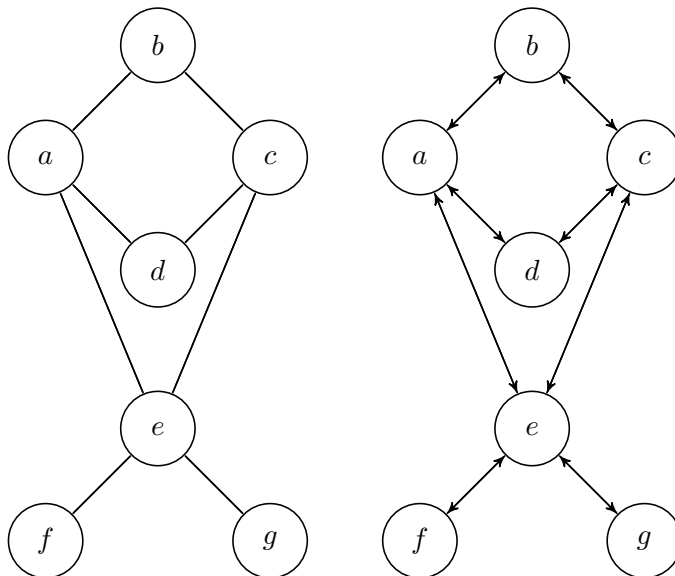

Throughout the remainder of this section, we will only consider directed graphs.

We state next an algorithm called *The Graph Conversion Algorithm (TGCA)* which converts any directed graph into a grammar which generates a language whose words are all the paths of a directed graph starting from a particular start vertex. We call such a language a *start-vertex graph language*.

**Definition 2.1.**

*INPUT: Digraph  $D = (V, E)$ .*

1. Give each vertex of  $D$  some label. The vertex labels represent the terminals of the grammar. It is important that the vertex labels are distinct from each other and distinct from the edge labels.
2. Label each edge of  $D$  with  $E_i$  where  $0 \leq i \leq |E|$ , and all the  $E_i$  are distinct. If the edges of  $D$  are already labeled, replace those labels with the  $E_i$  labels. These labels represent the nonterminals of the grammar.
3. Choose a start vertex. The start vertex designates the location in the graph where all the paths start. Let  $a \in V$  be the start vertex. Then for each outgoing edge  $E_i$  of  $a$ , write rules  $S \rightarrow aE_i$ . Then write the rule  $S \rightarrow a$ .

4. For each of the remaining vertices and for each outgoing edge  $E_j$  of each vertex, write rules  $E_i \rightarrow bE_j$ . Then write the rule  $E_i \rightarrow b$ , where  $b \in V$  and  $E_i$  is an incoming edge of  $b$ .
  5. For each of the incoming edges, make sure not to introduce duplicates. If the left side of  $E_i$  matches another nonterminals left side, replace all occurrences of  $E_i$  with the matched nonterminal.
- OUTPUT: A grammar  $G$  in TGCA form.

Before we move on we consider an example using TGCA.

**Example 2.2.** The graph on the left is the zero-divisor graph of  $\mathbb{Z}_{12}$ , and the graph on the right is the graph on the left after the labeling scheme defined by TGCA is applied (steps 1 - 3).

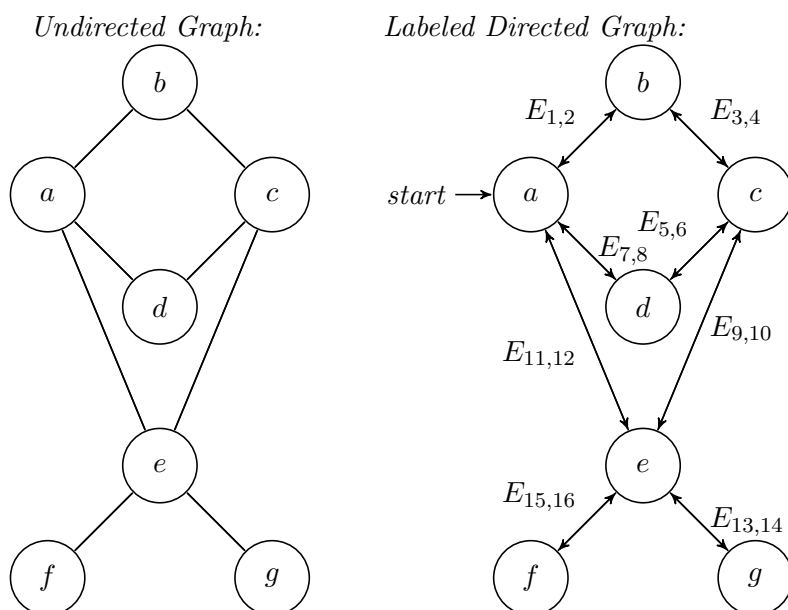

Next we follow steps 4 and 5 of the algorithm, and we obtain the following grammar in TGCA form.

$$\begin{aligned}
S &\rightarrow aE_1 \mid aE_7 \mid aE_{11} \mid a \\
E_1 &\rightarrow bS \mid bE_3 \mid b \\
E_7 &\rightarrow dS \mid dE_3 \mid d \\
E_{11} &\rightarrow eS \mid eE_3 \mid eE_{15} \mid eE_{13} \mid e \\
E_3 &\rightarrow cE_1 \mid cE_7 \mid cE_{11} \mid c \\
E_{15} &\rightarrow fE_{11} \mid f \\
E_{13} &\rightarrow gE_{11} \mid g.
\end{aligned}$$

This grammar generates the language whose words are every path starting from the vertex labeled  $a$  of the graph above.

We now prove that the output grammar is regular and has the smallest number of productions needed to generate a start-vertex graph language.

**Theorem 2.1.** *Every digraph  $G = (V, E)$  can be converted into a minimal regular grammar, where the number of production rules =  $|V| + |E|$ .*

*Proof.* By induction on the number of edges, take a digraph of two vertices with a single edge  $(a, b) = E_1$  as our base case. Then by TGCA the grammar is

$$\begin{aligned}
S &\rightarrow aE_1 \mid a \\
E_1 &\rightarrow b.
\end{aligned}$$

The number of productions is  $|E| + |V|$ , and this satisfies our base case.

Now assume the theorem and the algorithm are true up to  $|E| = n$  edges. Consider a graph with  $n + 1$  edges. We break it into two cases.

Case 1: We let the graph be connected with an arbitrary edge  $E_k$  which when removed the graph remains connected. The graph and the grammar in TGCA form are

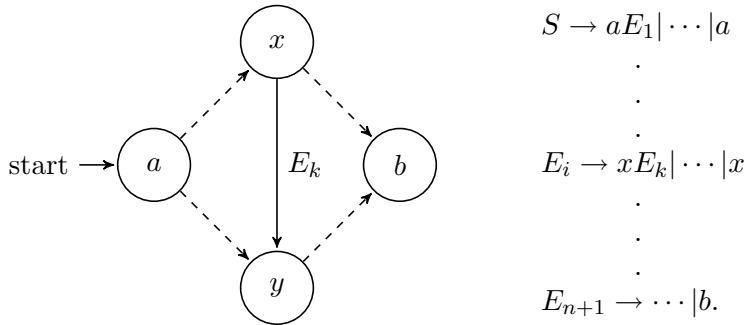

Consider Case 1. If we remove the edge labeled  $E_k$  from the graph, we obtain a graph of  $n$  edges; hence the inductive hypothesis applies. So, if we add the production  $E_i \rightarrow xE_k$  to the grammar in the inductive hypothesis, we obtain

$$\begin{aligned}
 S &\rightarrow aE_1 | \cdots | a \\
 &\quad \cdot \\
 &\quad \cdot \\
 &\quad \cdot \\
 E_i &\rightarrow xE_k | \cdots | x \\
 &\quad \cdot \\
 &\quad \cdot \\
 &\quad \cdot \\
 E_{n+1} &\rightarrow \cdots | b.
 \end{aligned}$$

This grammar remains regular by definition. This is a minimal regular grammar because our addition amounts to adding an additional edge labeled  $E_k$  to the graph in the inductive hypothesis, hence, the number of production rules =  $|V|+|E|$ , and it corresponds to the grammar obtained from the graph before the edge removal.

Case 2: We consider a graph that when an arbitrary edge  $E_k$  is removed we obtain a disconnected graph. This graph has the following form

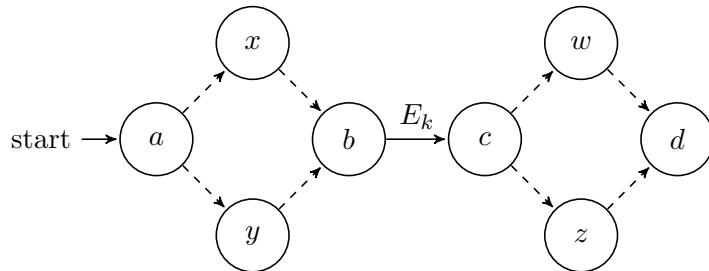

and its associated grammar in TGCA form is then

$$\begin{aligned}
S &\rightarrow aE_1|\cdots|a \\
&\vdots \\
&\vdots \\
E_i &\rightarrow bE_k|\cdots|b \\
&\vdots \\
&\vdots \\
E_k &\rightarrow \cdots|c \\
&\vdots \\
&\vdots \\
E_{n+1} &\rightarrow \cdots|d.
\end{aligned}$$

Now consider Case 2. If we remove the edge labeled  $E_k$ , we obtain two disjoint graphs with  $n$  or fewer edges. Thus, by the inductive hypothesis, we obtain two minimal regular grammars which correspond to the two disjoint graphs of  $n$  or fewer edges. If we add the production rule  $E_i \rightarrow bE_k$  to the first grammar, we obtain the grammar of the graph where the disjoint graphs are connected by the edge  $E_k$ . This grammar is regular by definition. Since our addition is only a single edge, the regular grammar remains minimal where the number of production rules =  $|V| + |E|$ .

□

At this point the regular grammars we are defining only generate start-vertex graph languages. Since we are working with regular grammars, and since regular grammars generate regular languages which are both closed under union ([15, 20]), we can use TGCA on every vertex of the graph and union the grammars together. Therefore, we obtain the regular language whose words are all the paths of a graph, called the *graph language*.

Up until now, we have discussed obtaining a graph language for any graph. Our research is mainly concerned with zero-divisor graphs, and our ultimate goal is to be able to move away from the zero-divisor graph completely and talk about languages. TGCA works for any graph, but it requires we work directly with the graph. So, we ask the question, is it possible to obtain the graph language of a zero-divisor graph without using the graph at all?

### 3. PROPERTIES OF GRAPH LANGUAGES

To answer this question let  $R$  be a ring, and define a function  $f : R \times R \rightarrow \{0, 1\}$  by

$$f(a, b) = \begin{cases} 1 & : ab = 0 \\ 0 & : otherwise \end{cases}$$



The function  $f$  determines if two nonzero elements of  $R$  multiply to zero. Using the previous function, we define  $\phi : \Sigma^* \rightarrow L$ , where  $\Sigma = Z(R)^*$ , by

$$\phi(a_0 \cdots a_n) = \begin{cases} a & : n = 1 \\ a_0 \cdots a_n & : f(a_0, a_1) = \cdots = f(a_{n-1}, a_n) = 1 \\ \lambda & : \text{otherwise.} \end{cases}$$

The regular language  $L$  contains as words all the paths of the zero-divisor graph of  $R$ , hence we denote this graph language, by  $L_R$  (the start-vertex graph language where every word starts with  $z \in Z(R)^*$  is denoted  $L_{R,z}$ ).

Since  $L_R$  is regular, it is possible to construct a finite automata which accepts the words of  $L_R$ . We construct such a machine directly from  $Z(R)^*$ . For all  $z_i \in Z(R)^*$ , write down a state labeled  $z_i$ . There exists an edge labeled  $z_i$  between two states  $z_i$  and  $z_j$  if and only if  $f(z_i, z_j) = 1$ . Every state of this machine is final. Choose  $z_i$  as the start state. This machine is an NFA which accepts all the words in  $L_{R,z_i}$ . We denote this machine by  $M_{NFA}(R, z_i)$ . Next write down a state labeled  $S$ . Connect an edge from  $S$  labeled  $z_i$  to its corresponding start state in  $M_{NFA}(R, z_i)$  for all  $z_i \in Z(R)$ . The state  $S$  is our new start state. This new machine is the NFA which accepts all the words of  $L_R$ , and we denote said NFA by  $M_{NFA}(R)$ . In fact,  $M_{NFA}(R) = \bigcup_{z \in Z(R)^*} M_{NFA}(R, z)$ . Likewise, we denote  $M_{NFA}(R, z_i)$ 's and  $M_{NFA}(R)$ 's equivalent DFAs as  $M_{DFA}(R, z_i)$  and  $M_{DFA}(R)$ , respectively.

To be able to completely move away from zero-divisor graphs, the graph languages must contain all the information obtainable from the graphs. In this section we show exactly where this information is hiding in the graph language.

**Definition 3.1.** *Let  $R$  be a ring. Then  $Fact(L_R) = \{ a_0 b_1 \cdots b_i a_1 \in L_R \mid a_0 \text{ and } a_1 \text{ are not necessarily distinct, } a_0 \neq a_1 \neq \lambda, b_i \text{'s are unique, and } b_i \neq a_0 \wedge b_i \neq a_1 \}$  is a set of subwords of length at least 2 composed of mainly unique symbols of all the words in  $L_R$ .*

In the previous definition we assert that the subwords are composed of mainly unique symbols, because the first and the last symbol may be equivalent.  $Fact(L_R)$  is easily constructed from the zero-divisor graph itself. Consider the zero-divisor graph associated with the paths in  $L_R$ . Starting from each vertex, follow each edge to every other vertex, writing down the path after crossing an edge. This set of paths is  $Fact(L_R)$ . We use this notion in the proof of the next theorem.

**Definition 3.2.** *A graph  $G$  is isomorphic to its associated graph language  $L_G$  if and only if there exists an one-to-one correspondence between the paths in  $G$  and the words in  $L_G$ .*

**Theorem 3.1.** *Let  $L$  be a graph language. Then  $L$  is isomorphic to its associated graph  $G$ .*

*Proof.* To prove Theorem 3.2 we construct  $Fact(L_R)$  directly from some arbitrary graph. Let  $G = (V, E)$  be a finite connected graph, where  $V = \{a_0, \dots, a_1\}$ , and let  $L$  be its associated graph language. Starting from  $a_0$ , write down the paths to each adjacent vertex. Let  $a_1$  be adjacent to  $a_0$ , then write down the paths starting with  $a_0a_1$  and ending at each adjacent vertex of  $a_1$ , excluding the edge took to get to  $a_1$ . Continue this pattern until an end is reached or  $a_0$  is reached forming a cycle. Do this for every vertex of  $G$ . This set of paths is exactly  $Fact(L)$ . Therefore,  $L$  is isomorphic to  $G$ .  $\square$

Theorem 3.2 implies that graphs and graph languages are interchangeable. This is a very pleasing result because it means among other things that all theorems, definitions, lemmas, corollaries, and so forth dealing with zero-divisor graphs ([1, 2, 3, 4, 5, 6, 8, 9, 10, 12, 13, 14, 16, 17, 18, 19]) have analogues in graph languages.

We now show that the NFA which accepts all the words in a zero-divisor graph language starting from a particular start-vertex is isomorphic to its associated zero-divisor graph.

**Definition 3.3.** *Let  $R$  be a ring and  $z \in Z(R)^*$ . Then a zero-divisor graph  $\Gamma(R)$  is isomorphic to a  $M_{NFA}(R, z)$  if and only if there exists a one-to-one correspondence  $\phi$  between the vertices of  $\Gamma(R)$  and the states of  $M_{NFA}(R, z)$  where  $a$  and  $b$  are two adjacent vertices of  $\Gamma(R)$  if and only if the state  $\phi(a)$  is connected to  $\phi(b)$  with an edge labeled  $a$  and  $\phi(b)$  is connected to  $\phi(a)$  with an edge labeled  $b$  in  $M_{NFA}(R, z)$ .*

**Theorem 3.2.** *Let  $R$  be a ring and let  $\Gamma(R)$  be its zero-divisor graph. Then each  $M_{NFA}(R, z)$  for each  $z \in Z(R)^*$  is isomorphic to  $\Gamma(R)$ .*

*Proof.* Let  $\phi : V(\Gamma(R)) \rightarrow S(M_{NFA}(R, z))$ , where  $z \in Z(R)^*$ , be defined by  $\phi(x) = x$ . By definition  $V(\Gamma(R)) = Z(R)^* = S(M_{NFA}(R, z))$ . Clearly,  $\phi$  is a one-to-one correspondence. Furthermore,  $z_i$  and  $z_j$  are adjacent in  $\Gamma(R)$  if and only if  $f(z_i, z_j) = 1$  and adjacent in  $M_{NFA}(R, z)$  if and only if  $f(z_i, z_j) = 1$ . Hence,  $z_i$  and  $z_j$  are adjacent if and only if  $\phi(z_i)$  and  $\phi(z_j)$  are as well with appropriately labeled edges. Therefore,  $\Gamma(R)$  and  $M_{NFA}(R, z)$  are isomorphic.  $\square$

Another proof of their equivalence can be found in the construction of  $M_{NFA}(R, z)$  directly from  $\Gamma(R)$ . We first convert  $\Gamma(R)$  into a directed graph, and we choose  $z$  as the start state. For each vertex  $x$  we label each outgoing edge  $x$ . All vertices are final states. This NFA is exactly  $M_{NFA}(R, z)$ .

Theorem 3.2 allows us to deduce some interesting properties of  $M_{NFA}(R, z)$ . For example, the length of the longest cycle in  $M_{NFA}(R, z)$  is less than or equal to 4, and the longest distance from any two states without taking a detour or cycle is less than or equal to 3 [2, 6, 16]. We now move away from the NFA's of graph languages toward their DFA's.

We next find an upper bound on the number of states of any  $M_{DFA}(R, z)$ .

**Theorem 3.3.** *The number of states in any  $M_{DFA}(R, z)$  where  $z \in Z(R)^*$  is less than or equal to  $|Z(R)^*| + 1$ .*

*Proof.* By subset construction, we can identify the states of  $M_{DFA}(R, z)$ . The subsets, and hence the set of states of  $DFA(M_{NFA}(R, z))$ , are  $Q = \{Q_z \mid Q_z = \{x \mid f(z, x) = 1 \text{ where } x \in Z(R)^*\} \text{ for all } z \in Z(R)^*\}$ . Now suppose  $|Q| > |Z(R)^*|$ . Then there must exist at least two elements  $Q_i, Q_j \in Q$  where  $Q_i \neq Q_j$  for a particular element of  $Z(R)^*$ . This is a contradiction. Therefore,  $|S| \leq |Z(R)^*| + 1$ .  $\square$

In Theorem 3.3 the NFA to DFA algorithm will obtain an extra state if and only if the start state is an end in  $\Gamma(R)$ . The subsets used in the proof can be constructed directly from  $\Gamma(R)$ . For each vertex  $v$ ,  $Q_i$  is the set of vertices adjacent to  $v$ . The distinct  $Q_i$ 's are the states of  $M_{DFA}(R, z)$ . We now turn to an example of when the number of states of a DFA is less than or equal to  $|Z(R)^*| + 1$ .

**Example 3.1.** *Consider the zero-divisor graph  $\Gamma(\mathbb{Z}_{12})$ .  $\Gamma(\mathbb{Z}_{12})$  has several symmetries, so, the NFA to DFA algorithm will output less states than there are vertices in  $\Gamma(\mathbb{Z}_{12})$ , because several vertices have the same set of neighbors. In fact,  $M_{DFA}(\mathbb{Z}_{12}, z)$  will have at most five states while  $Z(\mathbb{Z}_{12})^*$  has only seven vertices. Now consider the NFA of the graph language associated with the zero-divisor graph of the ring  $\mathbb{Z}_4[X]/(X^2 + X + 1)$ . The zero-divisor graph of this ring only has three vertices, but for any particular start vertex the DFA has exactly four states.*

Next we show exactly when the number of states of any  $M_{DFA}(R, z)$  is less than  $|Z(R)^*| + 1$  and we find the upper bound on the number of states in any  $M_{DFA}(R)$ .

**Theorem 3.4.** *Let  $R$  be a ring. The number of states in  $M_{DFA}(R, z)$  for some  $z \in Z(R)^*$  is less than  $|Z(R)^*| + 1$  if and only if there exists at least two distinct elements of  $x, y \in Z(R)^*$  such that  $Q_x = \{r \mid f(x, r) = 1 \text{ where } r \in Z(R)^*\} = \{s \mid f(y, s) = 1 \text{ where } s \in Z(R)^*\} = Q_y$ .*

*Proof.* ( $\Leftarrow$ ) By definition.

( $\Rightarrow$ ) Let  $R$  be a ring. Suppose for some  $z \in Z(R)^*$  we have  $|S(M_{DFA}(R, z))| < |Z(R)^*| + 1$ . Then  $|S(M_{DFA}(R, z)) - \{z\}| < |Z(R)^*|$ . By subset construction  $|S(M_{DFA}(R, z)) - \{z\}| \geq |Q|$ , where  $Q = \{Q_y \mid Q_y = \{x \mid f(y, x) = 1 \text{ where } x \in Z(R)^*\} \forall y \in Z(R)^*\}$ . Hence,  $|Q| < |Z(R)^*|$ . Let  $\phi : Z(R)^* \rightarrow Q$ , where  $\phi(a) = Q_a$ . By definition  $\phi$  is onto; thus, there exists an element of  $Z(R)^*$  for every element of  $Q$ , but  $|Q| < |Z(R)^*|$ ; hence,  $\phi$  is not one-to-one. However, by the definition of  $Q$  there exists an element of  $Z(R)^*$  for every element of  $Q$ . Therefore, there must exist at least two elements  $a, b \in Z(R)^*$  such that  $\phi(a) = \phi(b)$  and  $a \neq b$ .  $\square$

**Corollary 3.5.** *The number of states in any  $M_{NFA}(R)$  is less than or equal to  $|Z(R)^*|^2 + |Z(R)^*| + 1$ .*

*Proof.* Corollary 3.4 can be established easily by the notion that  $M_{NFA}(R) = \bigcup_{z \in Z(R)^*} M_{DFA}(R, z)$ . If each  $M_{DFA}(R, z)$  has the largest possible number of states, we will have a  $M_{DFA}(R, z)$  for each zero-divisor, and we obtain  $|Z(R)^*|$  DFA's with  $|Z(R)^*| + 1$  states. We link all these DFA's together with a new start state. Hence, we obtain the value in the corollary.  $\square$

In the last couple of theorems and corollaries, we established an upper bound on the number of states of the DFA's of zero-divisor graph languages. Next we establish a specific number of states for the DFA's of zero-divisor graphs languages when the NFA of a zero-divisor graph language is isomorphic to a star graph.

**Theorem 3.6.** *Let  $R$  be a ring and let  $z \in R$ . Then  $M_{NFA}(R, z)$  is isomorphic to a star graph if and only if  $DFA(M_{NFA}(R, z))$  has two states if ( $z$  is the center of  $M_{NFA}(R, z)$ ) or has three states (if  $z$  is an end-state of  $M_{NFA}(R, z)$ ).*

*Proof.* ( $\Rightarrow$ ) Let  $R$  be a ring and  $M_{NFA}(R, z)$  be the NFA which accepts all the words in the zero-divisor graph language of  $R$  starting with  $z$ . Suppose  $M_{NFA}(R, z)$  is isomorphic to a star-graph and let  $z$  be the center of  $M_{NFA}(R, z)$ . Then by subset construction let  $Q = \{Q_y \mid Q_y = \{x \mid f(y, x) = 1 \text{ where } x \in Z(R)^*\} \text{ for all } y \in Z(R)^*\}$  be the set of states of  $DFA(M_{NFA}(R, z))$ . Since the center of  $M_{NFA}(R, z)$  is  $z$ , then  $Q = \{Q_z, Q_x \mid Q_z = Z(R)^* - \{z\} \text{ and } Q_x = \{z\} \text{ for all } x \in Z(R)^* - \{z\}\}$ . Thus,  $|Q| = 2$ . Next assume  $z$  is an end-state of  $M_{NFA}(R, z)$ . Then  $Q$  is defined as before, but every word must start with  $z$ ; therefore, the set of states of  $DFA(M_{NFA}(R, z))$  is  $Q \cup \{z\}$ . Therefore  $|Q \cup \{z\}| = 3$ .

( $\Leftarrow$ ) Let  $S(DFA(M_{NFA}(R, q_0))) = \{q_0, q_1\}$ . If  $S(M_{NFA}(R, q_0)) = \{q_0, q_1\}$ , where  $q_0, q_1 \in Z(R)^*$ , then clearly  $M_{NFA}(R, q_0)$  is isomorphic to a star graph. If  $S(M_{NFA}(R, q_0)) = \{q_0, p_0, \dots, p_n\}$ , then  $q_1 \subseteq S(M_{NFA}(R, q_0))$  where  $q_1 \in Q = \{Q_x \mid Q_x = \{z \mid f(x, z) = 1 \text{ for all } z \in Z(R)^*\} \text{ for all } x \in Z(R)^*\}$  thus,  $Q_{p_i} = q_1, i = 0, \dots, n$ . Therefore,  $M_{NFA}(R, q_0)$  is isomorphic to a star graph.

We now consider three states. Let  $DFA(M_{NFA}(R, q_i))$  where  $i \in \{0, 1, 2\}$  have three states  $q_0, q_1$  and  $q_2$ . According to the NFA to DFA algorithm  $q_0, q_1$  and  $q_2$  fall into the following categories: 1.  $q_0 \in Z(R)^*$  and  $q_1, q_2 \subseteq Z(R)^*$ , 2.  $q_1 \in Z(R)^*$  and  $q_0, q_2 \subseteq Z(R)^*$ , 3.  $q_2 \in Z(R)^*$  and  $q_0, q_1 \subseteq Z(R)^*$ , 4.  $q_0, q_1 \in Z(R)^*$  and  $q_2 \subseteq Z(R)^*$ , 5.  $q_0, q_2 \in Z(R)^*$  and  $q_1 \subseteq Z(R)^*$ , 6.  $q_1, q_2 \in Z(R)^*$  and  $q_0 \subseteq Z(R)^*$ , and 7.  $q_0, q_1, q_2 \in Z(R)^*$ .

It is possible to rule out several categories from being DFAs of a zero-divisor graph. Consider category 7. All the states being zero-divisors implies that  $M_{NFA}(R, q_i)$ , where  $i \in \{0, 1, 2\}$ , is a DFA, and each  $q_i$  is adjacent to only one other vertex. This is impossible by the property that all zero-divisor graphs are undirected and Theorem 3.2.

Now consider categories 4 through 6. Without loss of generality, let  $q_0, q_1 \in Z(R)^*$  and  $q_2 \subseteq Z(R)^*$ , Then  $q_2$  is not adjacent to either  $q_0$  or

$q_1$ , because by the NFA to DFA algorithm  $q_2$  is adjacent to a subset of  $Z(R)^*$ . Hence, no DFAs have states in these categories.

Consider categories 1 through 3. Without loss of generality let  $q_0 \in Z(R)^*$  and  $q_1, q_2 \subseteq Z(R)^*$ . Then  $q_0$  is adjacent to only one of  $q_1$  or  $q_2$ , and neither  $q_1$  nor  $q_2$  is adjacent to  $q_0$ . Hence,  $q_0$  is the start state. If  $q_0$  is adjacent to  $q_1$ , then  $|q_1| = 1$  since  $q_0$  is an end in  $\Gamma(R)$ . Likewise, if  $q_0$  is adjacent to  $q_2$ , then  $|q_2| = 1$ . Now if  $q_0$  is adjacent to  $q_1$  and  $q_1$  is adjacent to  $q_2$ , then  $q_2$  is adjacent to  $q_1$  because  $\Gamma(R)$  is always undirected. Similar cases are true for when  $q_0$  and  $q_2$  are adjacent and when  $q_2$  and  $q_1$  are adjacent. One of the cases just stated must occur because  $\Gamma(R)$  is always connected [5, Theorem 2.3].

In any case there exists a subset  $x \subseteq Z(R)^*$  such that  $|x| = 1$  and all elements of  $Z(R)^* - x$  are adjacent to  $z \in x$ . Hence,  $z$  is adjacent to all elements of  $Z(R)^* - x$ . Now since every element of  $Z(R)^* - x$  is adjacent to only one element of  $Z(R)^*$ , every element of  $Z(R)^* - x$  is an end. Therefore,  $M_{NFA}(R, q_i)$  is adjacent to a star graph. Thus, category 1 through 3 is the only set that makes up an actual DFA, and the NFA of said DFA is isomorphic to a star graph.  $\square$

Anderson and Livingston in [5] showed that if  $\Gamma(R)$  has greater than or equal to 4 vertices then  $R$  is isomorphic to  $\mathbb{Z}_2 \times F$ , where  $F$  is a field, if and only if  $\Gamma(R)$  is a star graph. Thus, we obtain yet another corollary.

**Corollary 3.7.** *Let  $R$  be a ring with  $|Z(R)^*| \geq 4$ . Then  $M_{DFA}(R, z)$  for any  $z \in Z(R)^*$  has two or three states if and only if  $R \cong \mathbb{Z}_2 \times F$ , where  $F$  is a field.*

*Proof.* By [5, Theorem 2.13]  $\Gamma(R)$  is a star graph if and only if  $R \cong \mathbb{Z}_2 \times F$ . Then by Theorem 3.2  $\Gamma(R)$  is isomorphic to each  $M_{NFA}(R, z)$  for each  $z \in Z(R)^*$ . Therefore, by Theorem 3.7  $DFA(M_{NFA}(R, z))$  for each  $z \in Z(R)^*$  has two or three states if and only if  $M_{NFA}(R, z)$  is isomorphic to a star graph.  $\square$

#### 4. ACKNOWLEDGMENTS

I would like to thank Dr. Joe Stickles and Dr. James Rauff of Millikin University's Mathematics department for their exceptional feedback and suggestions. Without their help and interest this research would never have happened.

#### REFERENCES

- [1] S. Akbari, H.R. Maimani, and S. Yassemi. *When a zero-divisor graph is planar or a complete  $r$ -partite graph.* *J. Algebra*, **270**(1):169–180, 2003.
- [2] D.F. Anderson. *On the diameter and girth of a zero-divisor graph, II.* *Houston J. Math.*, **34**(2):361–371, 2008.
- [3] D.F. Anderson, A. Frazier, A. Lauve, and P.S. Livingston. *The zero-divisor graph of a commutative ring, II. Lectures Notes in Pure and Appl. Math.*, **220**:67–72, 2001.

- [4] D.F. Anderson, R. Levy, and J. Shapiro. *Zero-divisor graphs, von Neumann regular rings, and Boolean algebras*. *J. Pure Appl. Algebra*, **180**(3):221–241, 2003.
- [5] D.F. Anderson and P.S. Livingston. *The zero-divisor graph of a commutative ring*. *J. Algebra*, **217**(2):434–447, 1999.
- [6] D.F. Anderson and S.B. Mulay. *On the diameter and girth of a zero-divisor graph*. *J. Pure Appl. Algebra*, **210**(2):543–550, 2007.
- [7] M.F. Atiyah and I.G. MacDonald. *Introduction to Commutative Algebra*. Perseus Book, Cambridge, Massachusetts, 1969.
- [8] M. Axtell, J. Coykendall, and J. Stickles. *Zero-divisor graphs of polynomial and power series over commutative rings*. *Comm. Algebra*, **33**(6):2043–2050, 2005.
- [9] M. Axtell, J. Stickles, and W. Trampbachls. *Zero-divisor ideals and realizable zero-divisor graphs*. *Involve*, to appear.
- [10] R. Belshoff and J. Chapman. *Planar zero-divisor graphs*. *J. Algebra*, **316**(1):471–480, 2007.
- [11] G. Chartrand. *Introductory Graph Theory*. Dover Publications, New York, Mineola, 1985.
- [12] F. DeMeyer and K. Schneider. *Automorphisms and zero-divisor graphs of commutative rings*. *Int. J. Commut. Rings*, **1**(3):93–106, 2002.
- [13] J.D. LaGrange. *Complemented zero-divisor graphs and Boolean rings*. *J. Algebra*, **315**(2):600–611, 2007.
- [14] J.D. LaGrange. *On realizing zero-divisor graphs*. *Comm. Algebra*, **36**(12):4509–4520, 2008.
- [15] Peter Linz. *Formal Languages and Automata*. Jones and Bartlett Publishers, Sudbury, Massachusetts, 2006.
- [16] T.G. Lucas. *The diameter of a zero-divisor graph*. *J. Algebra*, **301**(1):174–193, 2006.
- [17] S.B. Mulay. *Cycles and symmetries of zero-divisors*. *Comm. Algebra*, **30**(7):3533–3558, 2002.
- [18] S.P. Redmond. *An ideal-based zero-divisor graph of a commutative ring*. *Comm. Algebra*, **31**(9):4425–4443, 2003.
- [19] S.P. Redmond. *On zero-divisor graphs of small finite commutative rings*. *Discrete Math.*, **307**(9):1155–1166, 2007.
- [20] G. Rozenberg and A. Eds. Salomaa. *Handbook of Formal Languages*, volume 1. Springer-Verlang, Berlin, Heidelberg, 1997.
- [21] A. Solomaa. *Jewels of Formal Language Theory*. Computer Science Press, Rockville, Maryland, 1981.

DEPARTMENT OF COMPUTER SCIENCE, UNIVERSITY OF IOWA, 14 MACLEAN HALL,  
IOWA CITY, IA 52242-1419

*E-mail address:* harley-eades@uiowa.edu