

A PROCEDURE FOR DETERMINING THE EXACT SOLUTION TO A 2×2 FIRST ORDER HOMOGENEOUS NONAUTONOMOUS SYSTEM

ALEXANDER K. SHVEYD

1. INTRODUCTION

To theorists in the mathematical field researching differential equations, obtaining the closed form solution to most first order homogeneous nonautonomous systems is known to be either exceedingly difficult or impossible. A first order homogeneous nonautonomous system has the form

$$\begin{aligned}x_1' &= p_{11}(t)x_1 + \cdots + p_{1n}(t)x_n \\x_2' &= p_{21}(t)x_1 + \cdots + p_{2n}(t)x_n \\&\vdots \qquad \qquad \qquad \vdots \\x_n' &= p_{n1}(t)x_1 + \cdots + p_{nn}(t)x_n\end{aligned}$$

Although numerous attempts have been made by various researchers to find a method to solve the general case, a successful technique remains elusive. For example, a paper by Caviglia and Morro [2] disproves an effort to do so using quadratures. The authors express the notion that such an achievement would be remarkable, but the ability to solve a first order homogeneous nonautonomous system using quadratures is a claim that still remains to be proven.

Nonautonomous systems, particularly periodic systems, are of great interest to mathematicians as well researchers from an assortment of scientific and engineering fields. The application of these systems is extensive. For example, electronics circuits are driven by clock signals with a specific period [4]. The dynamics of these circuits can be investigated with an appropriate nonautonomous system as a model. The oscillator is a recurring feature in numerous physical systems. With the use of Floquet and Lyapunov theories the stability of these linear periodic systems can be analyzed. Floquet theory, specifically, governs the structure of the solutions to periodic systems.

In this paper the author develops a technique for solving certain 2×2 first order homogeneous nonautonomous systems. While most mathematicians prefer to convert nonlinear differential equations into linear equations when seeking a solution, the method presented as the primary result solves a nonlinear equation in order to construct the exact solution of a linear system. The author's findings show that the exact solution to a 2×2 nonautonomous system is directly related to the solution of a Riccati differential equation that is constructed from the coefficients in the matrix $\mathbf{A}(t)$ of a system $\mathbf{x}' = \mathbf{A}(t)\mathbf{x}$, and the general structure of the exact solution to a nonautonomous system is similar to the general form of the exact solution for an autonomous system. However, without a method of solving the general Riccati differential equation, a procedure for determining the exact solution to a general 2×2 nonautonomous system remains elusive. Nevertheless, the main result does develop an approach for finding solutions to many complicated special cases.

This paper is composed of five sections. In the second section the relationship between the exact solution of a general 2×2 nonautonomous system and the general Riccati differential equation is developed by the author while the third portion of the paper provides four original examples of systems that were solved with the method presented in part two. The fourth section examines briefly the correlation between Floquet theory and an exact solution to a complicated periodic system. The paper concludes with a few comments on the extension of this method to autonomous and $n \times n$ systems.

2. THE STRUCTURE OF THE EXACT SOLUTION

The system under consideration is a first order homogeneous nonautonomous system of the form

$$\mathbf{x}' = \mathbf{A}(t)\mathbf{x}, \quad \mathbf{x}(t_0) = \mathbf{x}_0 \quad (1)$$

where $\mathbf{A}: \mathbb{R} \rightarrow \mathbb{R}^{2 \times 2}$ is continuous. In order to solve this system explicitly an assumption is made about the structure of the solutions. Since \mathbf{A} is a matrix function of the independent variable t , it is not unreasonable to assume that the solutions to (1) have a form analogous to the solutions of a first order autonomous system. However, ξ and r in this case are functions of t . This form is given by

$$\mathbf{x}(t) = \xi(t)e^{r(t)} \quad (2)$$

where the vector $\xi(t) \in \mathbb{R}^2$ and the function $r(t)$ in (2) have to be determined. Upon differentiation (2) becomes

$$\mathbf{x}'(t) = \xi'(t)e^{r(t)} + r'(t)\xi(t)e^{r(t)}. \quad (3)$$

If (2) and (3) are substituted into (1), the following system of equations can be obtained

$$(\mathbf{A}(t) - r'(t)\mathbf{I})\xi(t) = \xi'(t). \quad (4)$$

In order to determine $\xi(t)$ and $r(t)$ in (2), a solution to (4) must be found. A technique for finding the solution to (4) is not readily apparent from the present form. However, (4) can be expressed as

$$\begin{bmatrix} p_1(t) - r'(t) & p_2(t) \\ p_3(t) & p_4(t) - r'(t) \end{bmatrix} \begin{bmatrix} \xi_1 \\ \xi_2 \end{bmatrix} = \begin{bmatrix} \xi'_1 \\ \xi'_2 \end{bmatrix}. \quad (5)$$

The system defined by (5) is similar to the simultaneous algebraic equations that need to be solved in order to determine a solution to a first order autonomous system. However, in an autonomous system $\xi'(t) = 0$, r' is an eigenvalue of \mathbf{A} , and ξ is the corresponding eigenvector. ξ for an autonomous system can be expressed in the following simple form

$$\xi = \begin{bmatrix} \xi_1 \\ 1 \end{bmatrix} \quad (6)$$

where ξ_1 is a constant.

If the eigenvector ξ corresponding to the matrix \mathbf{A} of an autonomous system can be written in the form of vector (6), then it is reasonable to assume that $\xi(t)$ for a nonautonomous system can be expressed by a vector with a similar structure. However, in the nonautonomous case (6) would become

$$\xi(t) = \begin{bmatrix} \xi_1(t) \\ 1 \end{bmatrix}. \quad (7)$$

If (7) is substituted into (5), the following system results

$$\begin{bmatrix} p_1(t) - r'(t) & p_2(t) \\ p_3(t) & p_4(t) - r'(t) \end{bmatrix} \begin{bmatrix} \xi_1 \\ 1 \end{bmatrix} = \begin{bmatrix} \xi_1' \\ 0 \end{bmatrix}. \quad (8)$$

Equation (8) can be expressed as two separate equations.

$$(p_1(t) - r'(t))\xi_1 + p_2(t) = \xi_1', \quad (9)$$

$$p_3(t)\xi_1 + p_4(t) - r'(t) = 0. \quad (10)$$

If (10) is solved for $r'(t)$ and substituted into (9), then the following equation emerges

$$\xi_1' + p_3(t)\xi_1^2 + (p_4(t) - p_1(t))\xi_1 - p_2(t) = 0. \quad (11)$$

This equation has the form of the Riccati differential equation. Therefore, if (11) can be solved, both $\xi(t)$ and $r(t)$ can be determined from (7) and (10); and system (1) can be solved exactly.

It is well known that there are two linearly independent solutions for a 2×2 nonautonomous linear system $\mathbf{x}' = \mathbf{A}(t)\mathbf{x}$ where \mathbf{A} is a matrix valued function with continuous coefficients $p_1, p_2, p_3, p_4: \mathbb{R} \rightarrow \mathbb{R}$. The solutions to this system are vectors $\mathbf{x}_1 = \boldsymbol{\varphi}_1(t)$ and $\mathbf{x}_2 = \boldsymbol{\varphi}_2(t)$ where $\boldsymbol{\varphi}_1(t) \in \mathbb{R}^2$ and $\boldsymbol{\varphi}_2(t) \in \mathbb{R}^2$. The relationship of equation (11) with system (8) proves the following

Theorem 1. *The closed form solutions $\mathbf{x}_1 = \boldsymbol{\varphi}_1(t)$ and $\mathbf{x}_2 = \boldsymbol{\varphi}_2(t)$ can be determined explicitly if the Riccati differential equation $\xi' + p_3(t)\xi^2 + (p_4(t) - p_1(t))\xi - p_2(t) = 0$ can be solved explicitly.*

Unfortunately, a method to solve the general Riccati equation exactly has not yet been discovered. However, certain forms of the Riccati equation can be solved, and this class of solvable Riccati equations can be used to determine the exact solution to some interesting nonautonomous systems.

3. EXAMPLES OF HOW TO SOLVE NONAUTONOMOUS SYSTEMS

Example 1.

Consider the system

$$\mathbf{x}'(t) = \begin{bmatrix} p_1(t) & p_1(t) - p_2(t) \\ p_2(t) - p_1(t) & p_2(t) \end{bmatrix} \mathbf{x}(t) \quad (12)$$

Using (11) the Riccati equation corresponding to (12) is

$$\xi_1' + (p_2(t) - p_1(t))\xi_1^2 + (p_2(t) - p_1(t))\xi_1 + (p_2(t) - p_1(t)) = 0. \quad (13)$$

Differential equation (13) can be solved by separation of variables. Using this technique produces

$$\int \frac{d\xi_1}{\xi_1^2 + \xi_1 + 1} = - \int (p_2(t) - p_1(t)) dt. \quad (14)$$

The solution to (14) is

$$\xi_1(t) = \frac{\sqrt{3}}{2} \tan \left(k - \frac{\sqrt{3}}{2} \int (p_2(t) - p_1(t)) dt \right) - \frac{1}{2}. \quad (15)$$

Equations (7) and (10) can then be used to find $\xi(t)$ and $r(t)$, which are given by

$$\xi(t) = \begin{bmatrix} \frac{\sqrt{3}}{2} \tan \left(k - \frac{\sqrt{3}}{2} \int (p_2(t) - p_1(t)) dt \right) - \frac{1}{2} \\ 1 \end{bmatrix}, \quad (16)$$

$$r(t) = \ln \left(\cos \left(\frac{\sqrt{3}}{2} \int p_1(t) - p_2(t) dt + k \right) \right) + \frac{1}{2} \int p_1(t) + p_2(t) dt. \quad (17)$$

Equation (16) and (17) can then be substituted into (2), and with the use of the following trigonometric identities

$$\begin{aligned} \cos(a+b) &= \cos(a)\cos(b) - \sin(a)\sin(b) \\ \sin(a+b) &= \cos(a)\sin(b) + \sin(a)\cos(b) \end{aligned}$$

the resulting expression can be simplified into two linearly independent solutions. Each solution will be proportional to a different constant. In this example, $\cos(k)$ and $\sin(k)$ are

the two proportionality constants that distinguish the solutions. Since the values of $\cos(k)$ and $\sin(k)$ are determined by initial conditions, these terms can be simply redefined as c_1 and c_2 .

A specific example helps illustrate the process needed to solve system (12). For example, if $p_1(t) = \cos(t)$ and $p_2(t) = \sin(t)$, then (12) becomes

$$\mathbf{x}'(t) = \begin{bmatrix} \cos(t) & \cos(t) - \sin(t) \\ \sin(t) - \cos(t) & \sin(t) \end{bmatrix} \mathbf{x}(t). \quad (18)$$

The functions $\xi(t)$ and $r(t)$ for this specific system are

$$\xi(t) = \begin{bmatrix} \frac{\sqrt{3}}{2} \tan \left(k_1 + \frac{\sqrt{3}}{2} (\sin(t) + \cos(t)) \right) - \frac{1}{2} \\ 1 \end{bmatrix}, \quad (19)$$

$$r(t) = \ln \left(\cos \left(k_1 + \frac{\sqrt{3}}{2} (\sin(t) + \cos(t)) \right) \right) + \frac{1}{2} (\sin(t) - \cos(t)). \quad (20)$$

By substituting (19) and (20) into equation (2) and using the given trigonometric identities the exact form for both solutions to system (18) can be determined. The general solution is

$$\begin{aligned} \mathbf{x}(t) = & c_1 e^{\frac{1}{2}(\sin(t) - \cos(t))} \begin{bmatrix} \frac{\sqrt{3}}{2} \cos \left(\frac{\sqrt{3}}{2} (\sin(t) + \cos(t)) \right) + \frac{1}{2} \sin \left(\frac{\sqrt{3}}{2} (\sin(t) + \cos(t)) \right) \\ - \sin \left(\frac{\sqrt{3}}{2} (\sin(t) + \cos(t)) \right) \end{bmatrix} \\ & + c_2 e^{\frac{1}{2}(\sin(t) - \cos(t))} \begin{bmatrix} \frac{\sqrt{3}}{2} \sin \left(\frac{\sqrt{3}}{2} (\sin(t) + \cos(t)) \right) - \frac{1}{2} \cos \left(\frac{\sqrt{3}}{2} (\sin(t) + \cos(t)) \right) \\ \cos \left(\frac{\sqrt{3}}{2} (\sin(t) + \cos(t)) \right) \end{bmatrix}. \end{aligned} \quad (21)$$

As can be seen from this example, the exact solutions of 2×2 nonautonomous systems can be rather complicated. When this solution is plotted in the phase plane (Figure 1), the trajectories overlap, a characteristic of nonautonomous systems. However, this does not signify a violation of the uniqueness theorem. If the solutions are plotted in the phase plane with the independent variable t along the third axis (Figure 2), it is quite evident that none of the trajectories pass through the same point for the same value of t . Therefore, the trajectories evolve through time independently and never cross. Hence, uniqueness is preserved.

A plot of (21) for various initial conditions shows clearly the overlapping trajectories.

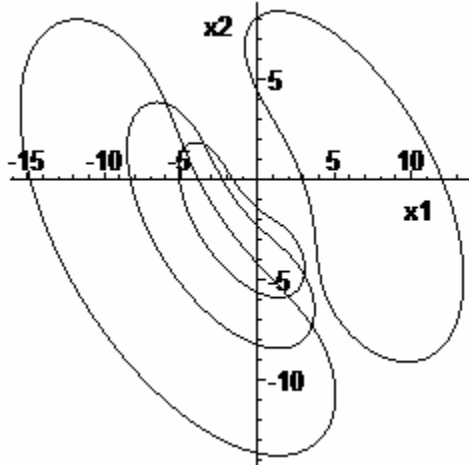

Figure 1

If the same graph is plotted with t along the x_3 axis and rotated by $\pi/2$ about the x_1 axis, it is undoubtedly apparent that none of the trajectories pass through the same point for the same value of t .

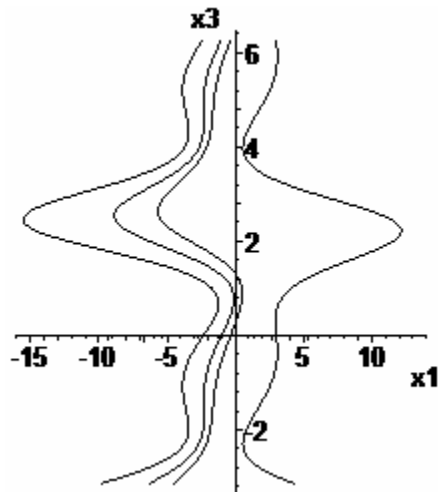

Figure 2

Example 2.

A noticeably complicated system that can be solved explicitly, by the technique presented in section two, is given by

$$\mathbf{x}'(t) = \begin{bmatrix} -p_1(t)p_2(t) & p_1(t)p_2(t)^2 + p_2'(t) \\ -p_1(t) & p_1(t)p_2(t) \end{bmatrix} \mathbf{x}(t). \quad (22)$$

At first, solving this type of system exactly seems improbable. However, due to the symmetry of the coefficients in the matrix, the Riccati equation associated with (22) can be solved exactly. Consequently, a solution to the system can be found. The corresponding Riccati equation is

$$\xi_1' - p_1(t)(\xi_1 - p_2(t))^2 - p_2'(t) = 0. \quad (23)$$

Riccati differential equations have an interesting property [6]. If a particular solution is known, the general solution can be obtained by using the substitution $\xi_g = u + \xi_p$. A particular solution for (23) is $p_2(t)$. Therefore, the substitution that needs to be used to solve (23) is

$$\xi_1 = u + p_2(t). \quad (24)$$

If (24) is substituted into (23), the resultant equation is

$$u' - p_1(t)u^2 = 0. \quad (25)$$

This equation can be solved by separation of variables. After the solution of (25) is substituted into (24), the general solution to (23) becomes

$$\xi_1(t) = p_2(t) - \frac{1}{\int p_1(t) dt + k}. \quad (26)$$

Using (7) and (10), $\xi(t)$ and $r(t)$ for this system are

$$\xi(t) = \begin{bmatrix} p_2(t) - \frac{1}{\int p_1(t) dt + k} \\ 1 \end{bmatrix}, \quad (27)$$

$$r(t) = \int p_1(t) \left(\int p_1(t) dt + k \right)^{-1} dt. \quad (28)$$

If $p_1(t) = \cos(t)$ and $p_2(t) = \cos(t)$, system (22) becomes

$$\mathbf{x}'(t) = \begin{bmatrix} -\cos^2(t) & \cos^3(t) - \sin(t) \\ -\cos(t) & \cos^2(t) \end{bmatrix} \mathbf{x}(t). \quad (29)$$

The functions $\xi(t)$ and $r(t)$ associated with (29) are given by

$$\xi(t) = \begin{bmatrix} \cos(t) - \frac{1}{\sin(t) + k} \\ 1 \end{bmatrix}, \quad (30)$$

$$r(t) = \ln(\sin(t) + k). \quad (31)$$

With the use of (2) the general solution for this system becomes

$$\mathbf{x}(t) = c_1 \begin{bmatrix} \cos(t) \sin(t) - 1 \\ \sin(t) \end{bmatrix} + c_2 \begin{bmatrix} \cos(t) \\ 1 \end{bmatrix}. \quad (32)$$

Equation (32) is an interesting expression because it is a rather simple solution for a seemingly complicated system. This is a stark contrast to (21), the solution to system (18). Due to the periodic nature of (32), a plot with various initial conditions in phase space reveals trajectories that are closed curves (Figure 3).

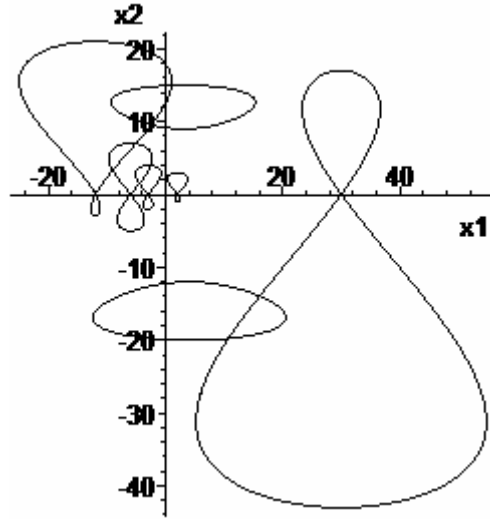

Figure 3

Example 3.

In this example the nonautonomous system also has a complicated matrix, but unlike Example 2, the exact solution for the system is equally intricate. The system is given by

$$\mathbf{x}'(t) = \begin{bmatrix} a & p_1(t)p_2'(t) \\ a & -p_1'(t) \\ p_1(t)p_2(t) & p_1(t) \end{bmatrix} \mathbf{x}(t). \quad (33)$$

For this system a is a constant. The Riccati equation that pertains to (33) is

$$\xi_1' + \frac{a}{p_1(t)p_2(t)} \xi_1^2 - \left(\frac{p_1'(t)}{p_1(t)} + a \right) \xi_1 - p_1(t)p_2'(t) = 0. \quad (34)$$

Equation (34) can be solved by the same method that was utilized to solve (23). It may not be immediately obvious, but a particular solution to (34) is $p_1(t)p_2(t)$. Therefore, the substitution that should be used to find a general solution to (34) is

$$\xi_1 = u + p_1(t)p_2(t). \quad (35)$$

After the substitution of (35) into (34) the resultant equation is

$$u' + \frac{a}{p_1(t)p_2(t)} u^2 + \left(-\frac{p_1'(t)}{p_1(t)} + a \right) u = 0. \quad (36)$$

Equation (36) has the form of a quadratic Bernoulli equation. This equation can be transformed into a first order ordinary differential equation with the substitution

$$u = w^{-1}. \quad (37)$$

Upon substitution of (37) into (36) the Bernoulli differential equation transforms into

$$w' + \left(\frac{p_1'(t)}{p_1(t)} - a \right) w - \frac{a}{p_1(t)p_2(t)} = 0. \quad (38)$$

The technique for solving (38) is well known [1], and the solution is

$$w = \frac{e^{at}}{p_1(t)} \left(a \int \frac{e^{-at}}{p_2(t)} dt + k \right). \quad (39)$$

After some back-substitution the solution to (34) becomes

$$\xi_1(t) = p_1(t)p_2(t) + \frac{e^{-at} p_1(t)}{\left(a \int \frac{e^{-at}}{p_2(t)} dt + k \right)}. \quad (40)$$

Once again with the use of (7) and (10), $\xi(t)$ and $r(t)$ for this system are given by

$$\xi(t) = \begin{bmatrix} p_1(t)p_2(t) + \frac{e^{-at} p_1(t)}{\left(a \int \frac{e^{-at}}{p_2(t)} dt + k \right)} \\ 1 \end{bmatrix}, \quad (41)$$

$$r(t) = \ln \left(\frac{a \int \frac{e^{-at}}{p_2(t)} dt + k}{p_1(t)} \right) + at. \quad (42)$$

A specific example helps clarify what (33), (41), and (42) look like with specific functions in place of p_1 and p_2 . If $p_1 = t^2$, $p_2 = \sin^{-1}(t)$, and $a=1$, system (33) becomes

$$\mathbf{x}'(t) = \begin{bmatrix} 1 & \frac{t^2}{\sqrt{1-t^2}} \\ \frac{1}{t^2 \sin^{-1}(t)} & -\frac{2}{t} \end{bmatrix} \mathbf{x}(t). \quad (43)$$

The functions $\xi(t)$ and $r(t)$ corresponding to (43) are given by

$$\xi(t) = \begin{bmatrix} t^2 \sin^{-1}(t) + \frac{t^2 e^{-t}}{\left(\int \frac{e^{-t}}{\sin^{-1}(t)} dt + k \right)} \\ 1 \end{bmatrix}, \quad (44)$$

$$r(t) = \ln \left(\frac{\int \frac{e^{-t}}{\sin^{-1}(t)} dt + k}{t^2} \right) + t. \quad (45)$$

With the use of (2) the general solution of (43) is expressed by

$$\mathbf{x}(t) = c_1 \begin{bmatrix} e^t \sin^{-1}(t) \int \frac{e^{-t}}{\sin^{-1}(t)} dt + 1 \\ t^{-2} e^t \int \frac{e^{-t}}{\sin^{-1}(t)} dt \end{bmatrix} + c_2 \begin{bmatrix} e^t \sin^{-1}(t) \\ t^{-2} e^t \end{bmatrix}. \quad (46)$$

The phase plot for system (43) is given by Figure 4.

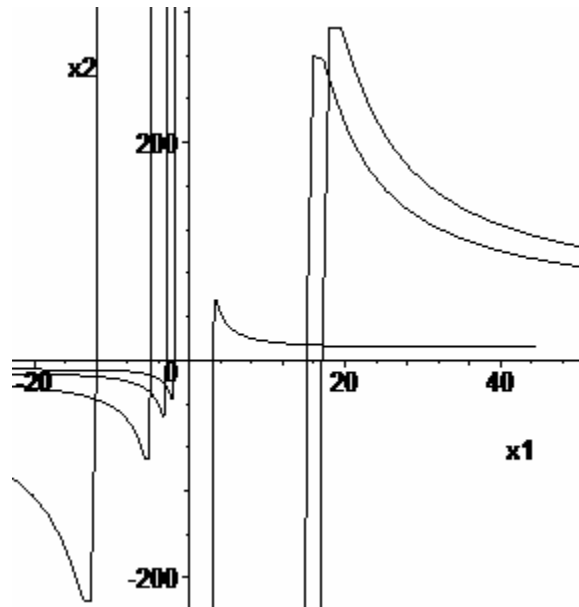

Figure 4

Example 4.

Consider the system

$$\mathbf{x}'(t) = \begin{bmatrix} 0 & (a-1) \frac{p'(t)}{p(t)^2} \\ a p'(t) & 0 \end{bmatrix} \mathbf{x}(t). \quad (47)$$

The Riccati equation that must be solved to find a general solution for (47) is expressed by

$$\xi_1' + a p'(t) \xi_1^2 - (a-1) \frac{p'(t)}{p(t)^2} = 0. \quad (48)$$

A particular solution to (48) is $1/p(t)$. Using the method that was utilized in Example 2 and Example 3, equation (48) can be converted into a Bernoulli equation with the substitution

$$\xi_1 = u + \frac{1}{p(t)}. \quad (49)$$

After (49) is substituted into (48) the equation that emerges is

$$u' + a p'(t)u^2 + 2a \frac{p'(t)}{p(t)}u = 0. \quad (50)$$

This equation can be converted into a first order linear differential equation with the substitution given by (37). Equation (37) substituted into (50) produces

$$w' - 2a \frac{p'(t)}{p(t)}w - a p'(t) = 0. \quad (51)$$

The solution to (51) is given by

$$w = p(t)^{2a} \left(a \int p(t)^{-2a} p'(t) dt + k \right). \quad (52)$$

With the use of (37), (49), (7), and (10), $\xi(t)$ and $r(t)$ for system (47) are found to be

$$\xi(t) = \begin{bmatrix} \frac{p(t)^{-2a}}{\left(a \int p(t)^{-2a} p'(t) dt + k \right) + \frac{1}{p(t)}} \\ 1 \end{bmatrix}, \quad (53)$$

$$r(t) = \ln \left(p(t)^a \left(a \int p(t)^{-2a} p'(t) dt + k \right) \right). \quad (54)$$

If $p(t) = \cos(t)$ and $a = \frac{1}{3}$, system (47) becomes

$$\mathbf{x}'(t) = \begin{bmatrix} 0 & \frac{2 \sin(t)}{3 \cos^2(t)} \\ -\frac{1}{3} \sin(t) & 0 \end{bmatrix} \mathbf{x}(t). \quad (55)$$

Using (53), (54), and (2) the general solution for this system is

$$\mathbf{x}(t) = c_1 \begin{bmatrix} \cos^{-\frac{2}{3}}(t) \\ \cos^{\frac{1}{3}}(t) \end{bmatrix} + c_2 \begin{bmatrix} 2 \cos^{-\frac{1}{3}}(t) \\ \cos^{\frac{2}{3}}(t) \end{bmatrix}. \quad (56)$$

Figure 5 shows a plot of (56) for various initial values.

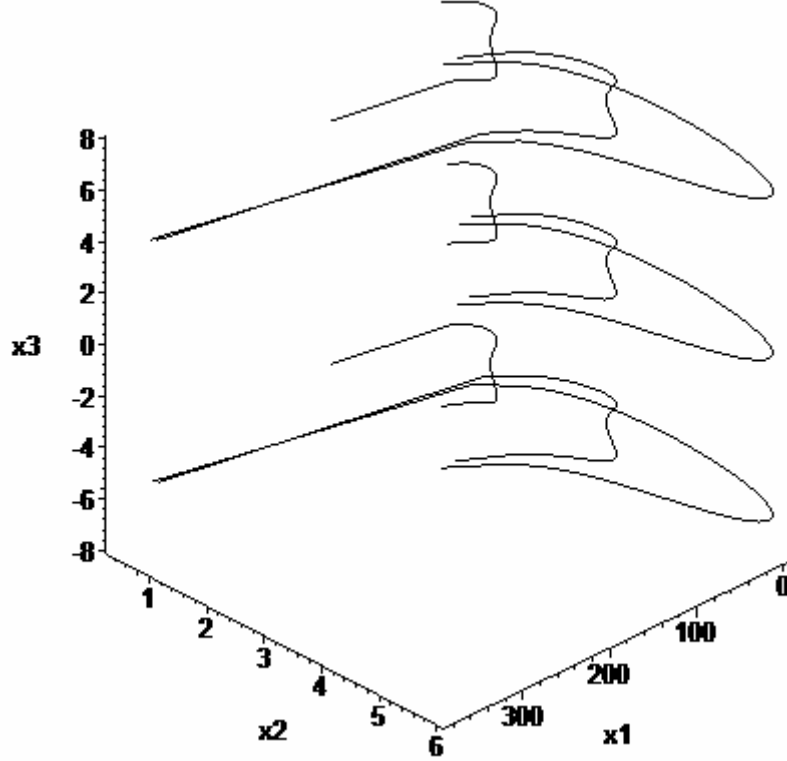

Figure 5

4. A BRIEF EXAMINATION OF FLOQUET THEORY

The functions chosen in Examples 1, 2, and 4 were periodic. Therefore, $\mathbf{A}(t)$ for each system is a periodic matrix function that satisfies the condition $\mathbf{A}(t) = \mathbf{A}(t+T)$ for all $t \in \mathbb{R}$. The structure of the solutions to periodic linear systems is described by Floquet Theory. The Floquet Theorem for linear systems states

Theorem 2. $\Phi(t)$ is the fundamental matrix to a system described by $\mathbf{x}' = \mathbf{A}(t)\mathbf{x}$ where $\mathbf{A}: \mathbb{R} \rightarrow \mathbb{R}^{n \times n}$; and $\mathbf{A}(t) = \mathbf{A}(t+T)$ with a period T . If $\Phi(t)$ satisfies the periodic system, then so does $\Phi(t+T)$. $\Phi(t)$ can be decomposed as

$$\Phi(t) = \mathbf{P}(t)e^{i\mathbf{R}t} \quad (57)$$

where $\mathbf{P}(t) \in \mathbb{C}^{n \times n}$; $\mathbf{P}(t) = \mathbf{P}(t+T)$ with a period T ; and $\mathbf{R} \in \mathbb{C}^{n \times n}$ is a constant valued matrix [5]

Using the technique developed in this paper, the consistency of Floquet theory with the Riccati equation approach can be examined.

Example 5.

Consider the linear periodic system

$$\mathbf{x}'(t) = \begin{bmatrix} -\cos^2(t)\sin(t) & \cos^2(t)\sin^2(t) + \cos(t) \\ -\cos^2(t) & \cos^2(t)\sin(t) \end{bmatrix} \mathbf{x}(t). \quad (58)$$

It is quite obvious that the period of this system is 2π . The fundamental matrix of (58) is

$$\Phi(t) = \begin{bmatrix} -\frac{\sin^2(t)\cos(t)}{2} - \frac{t\sin(t)}{2} + 1 & \sin(t) \\ \frac{-\sin(t)\cos(t)}{2} - \frac{t}{2} & 1 \end{bmatrix}. \quad (59)$$

Matrix (59) was determined using the technique developed in Example 2. $\Phi(t+2\pi)$ also satisfies system (58) and has the form

$$\Phi(t+2\pi) = \begin{bmatrix} -\frac{\sin^2(t)\cos(t)}{2} - \frac{t\sin(t)}{2} + 1 & \sin(t) \\ \frac{-\sin(t)\cos(t)}{2} - \frac{t}{2} & 1 \end{bmatrix} - \pi \begin{bmatrix} \sin(t) & 0 \\ 1 & 0 \end{bmatrix}. \quad (60)$$

However, to decompose (59) into (57) a constant matrix \mathbf{R} must be found. \mathbf{R} is given by

$$\mathbf{R} = \frac{1}{T} \ln \Phi_t(t_0 + T, t_0) \quad (61)$$

where Φ_t is the transition matrix [3]. In this case Φ_t becomes

$$\Phi_t(2\pi, 0) = \begin{bmatrix} 1 & 0 \\ -\pi & 1 \end{bmatrix}. \quad (62)$$

Therefore, \mathbf{R} and $e^{t\mathbf{R}}$ for system (58) are

$$\mathbf{R} = \frac{1}{2\pi} \ln \Phi_t(2\pi, 0) = \begin{bmatrix} 0 & 0 \\ -\frac{1}{2} & 0 \end{bmatrix}, \quad (63)$$

$$e^{\begin{bmatrix} 0 & 0 \\ -\frac{t}{2} & 0 \end{bmatrix}} = \begin{bmatrix} 1 & 0 \\ -\frac{t}{2} & 1 \end{bmatrix}. \quad (64)$$

Using (57) the periodic matrix $\mathbf{P}(t)$ can be found and is given by

$$\mathbf{P}(t) = \mathbf{\Phi}(t)e^{-t\mathbf{R}} = \begin{bmatrix} 1 - \frac{\sin^2(t)\cos(t)}{2} & \sin(t) \\ \frac{-\sin(t)\cos(t)}{2} & 1 \end{bmatrix}. \quad (65)$$

5. CONCLUSION

The technique developed in this paper can be used to find the exact solutions to 2×2 , and possibly larger, autonomous systems. It produces the same results as those obtained from the eigenvalue method. However, the procedure is rather tedious, and the eigenvalue method is much more effective. This is mentioned only to establish the fact that this technique can be employed to determine the exact solution of any 2×2 homogeneous first order linear system as long as the corresponding Riccati equation can be solved.

With regard to $n \times n$ systems, there is no reason to believe that this technique will fail with larger nonautonomous systems. However, to solve such systems exactly would involve finding a solution to a system of nonlinear differential equations, rather than just solving the Riccati differential equation. If there is no procedure for solving the general form of the Riccati equation, then it is quite unlikely that a solution to a general system of nonlinear equations can be found. Nevertheless, it is quite feasible that exact solutions to some particular $n \times n$ systems can be determined.

REFERENCES

- [1] W. Boyce and R. DiPrima, *Elementary Differential Equations and Boundary Value Problems*; seventh ed., John Wiley & Sons, Inc., New York, NY, 2001.
- [2] G. Caviglia and A. Morro, Solving Linear Differential Equations by Quadratures: Comments on a General Procedure, *Internat. J. Math. Math. Sci.* **24** (2000), no. 1, 63-65.
- [3] J. J. Dacunha and J. M. Davis, Periodic Linear Systems: Lyapunov Transformations and a Unified Floquet Theory for Time Scales, *Jeffrey J. DaCunha's Homepage*, Dept. of Mathematics, Baylor University. 20 May 2004 <http://www3.baylor.edu/~Jeffrey_Dacunha>
- [4] M. Di Bernardo and C. K. Tse, Complex Behavior in Switching Power Converters, *Pro. IEEE* **90** (2000), no. 5, 768-781
- [5] S. Hsu, Ordinary Differential Equations, Dept. of Mathematics, National Tsing Hua University. 3 May 2004 <<http://math2.math.nthu.edu.tw/sbhsu/book/ode0904>>
- [6] R. S. Kaushal and D. Parashar, *Advanced Methods of Mathematical Physics*. Alpha Science Intl. Ltd., Middlesex, United Kingdom, 2000.
- [7] W. T. Reid, *Riccati Differential Equations*, *Math. Sci. Eng.* **86**, Academic Press, New York, NY, 1972.
- [8] W. Yuan, A Note on the Riccati Differential Equation, *J. Math. Anal. Appl.* **277** (2003), 367-374.