

Panel 1

Prior to Le21

# PLC Intro and Ladder Logic

ME430 Mechatronics

1

Panel 2

## PLC - Programmable Logic Controller



2

Panel 3

### How does a PLC compare to a pic?

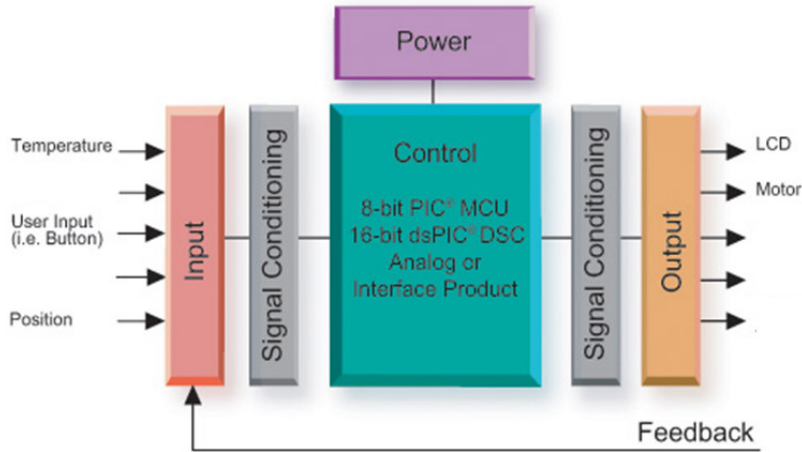

3

Panel 4

### Basic digital inputs and outputs



4

Panel 5

Totally different programming methods - Purely graphical!

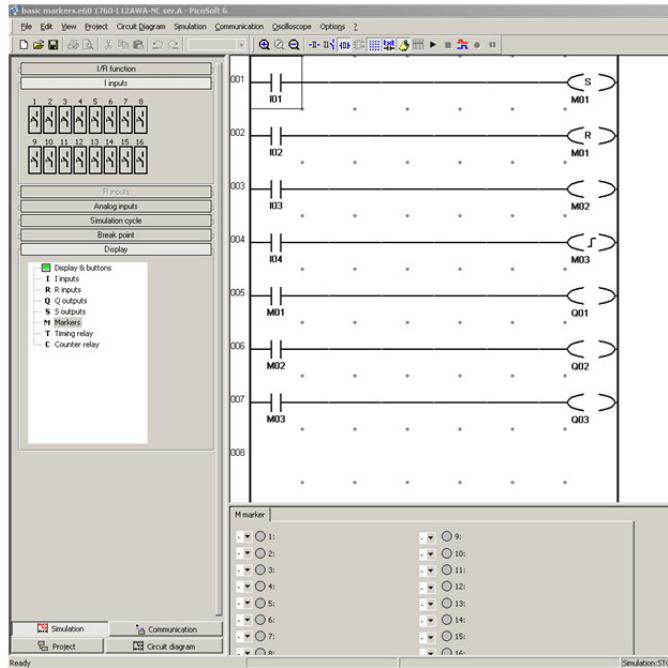

5

Panel 6

Input Types

Normally Open

Normally Closed

Momentary

Position

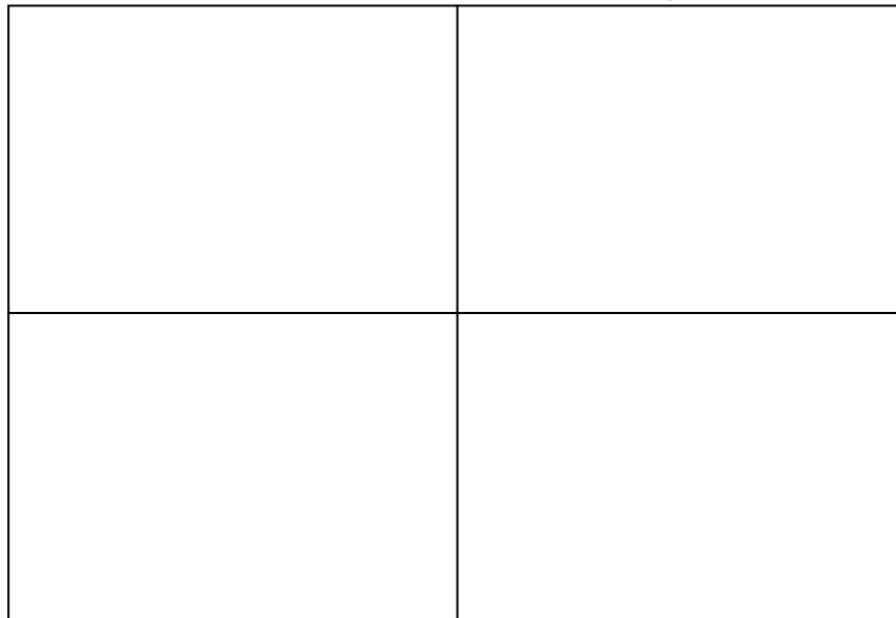

6

Panel 7

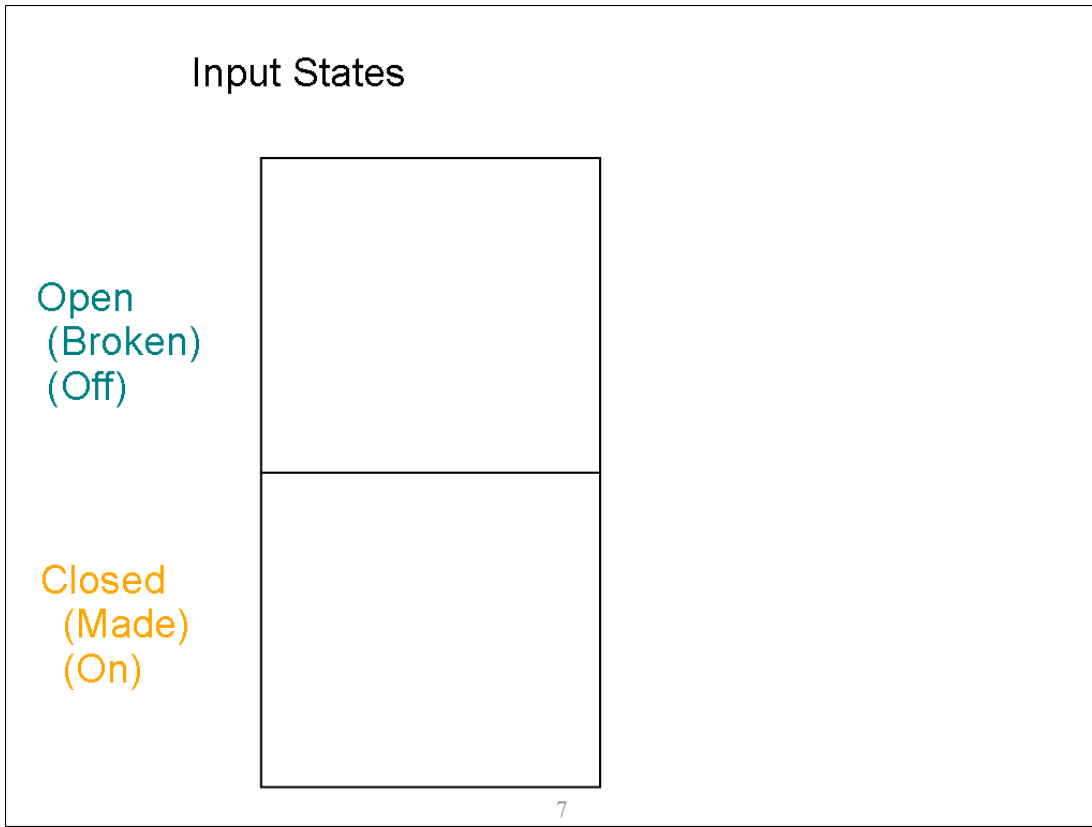

Panel 8

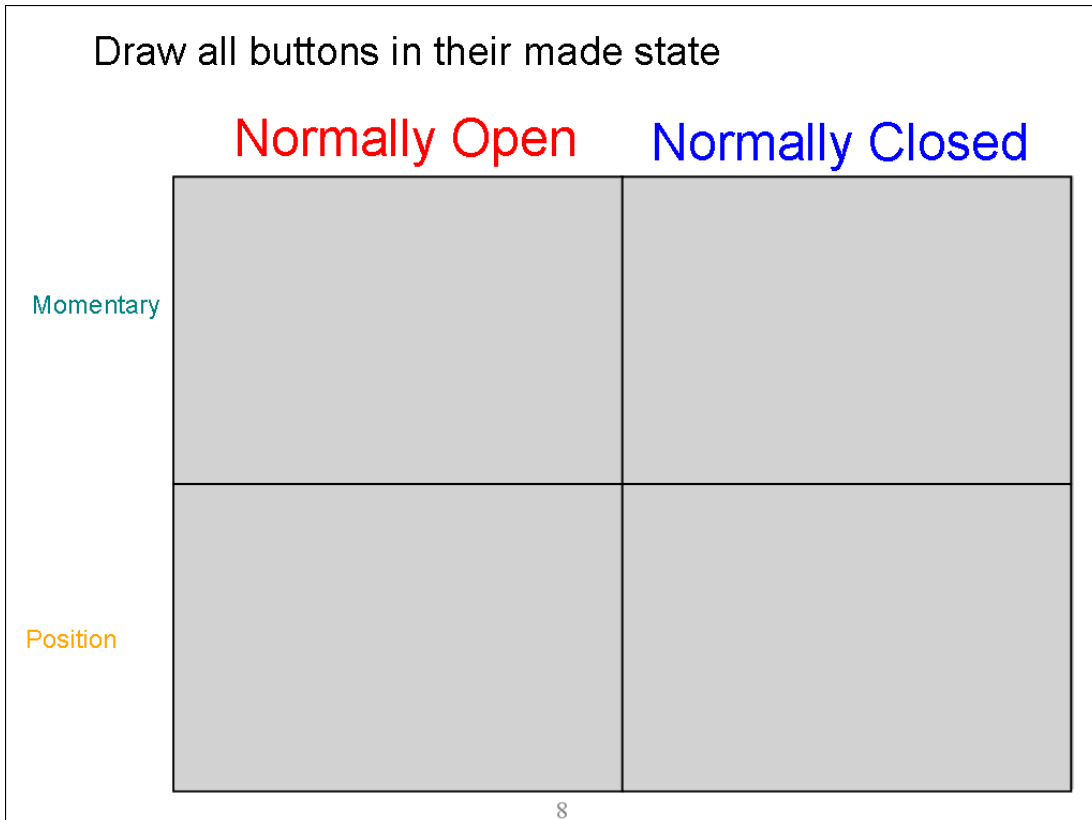

Panel 9

### Button types in Picosoft



Panel 10



Panel 11

Why is it called ladder logic?

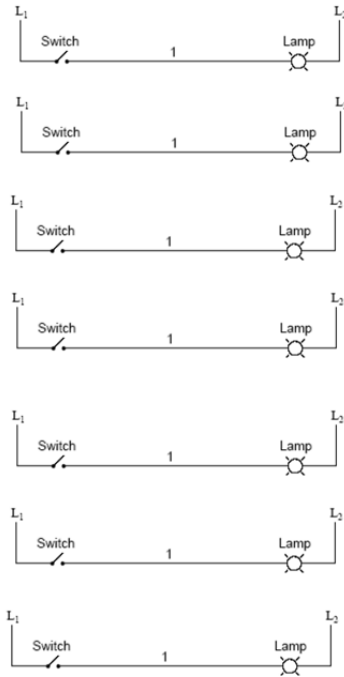

Looks like a ladder

Panel 12

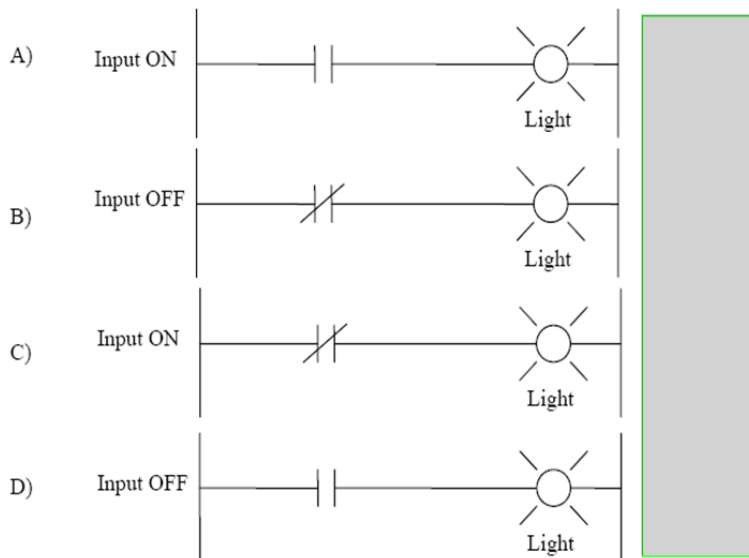

Panel 13

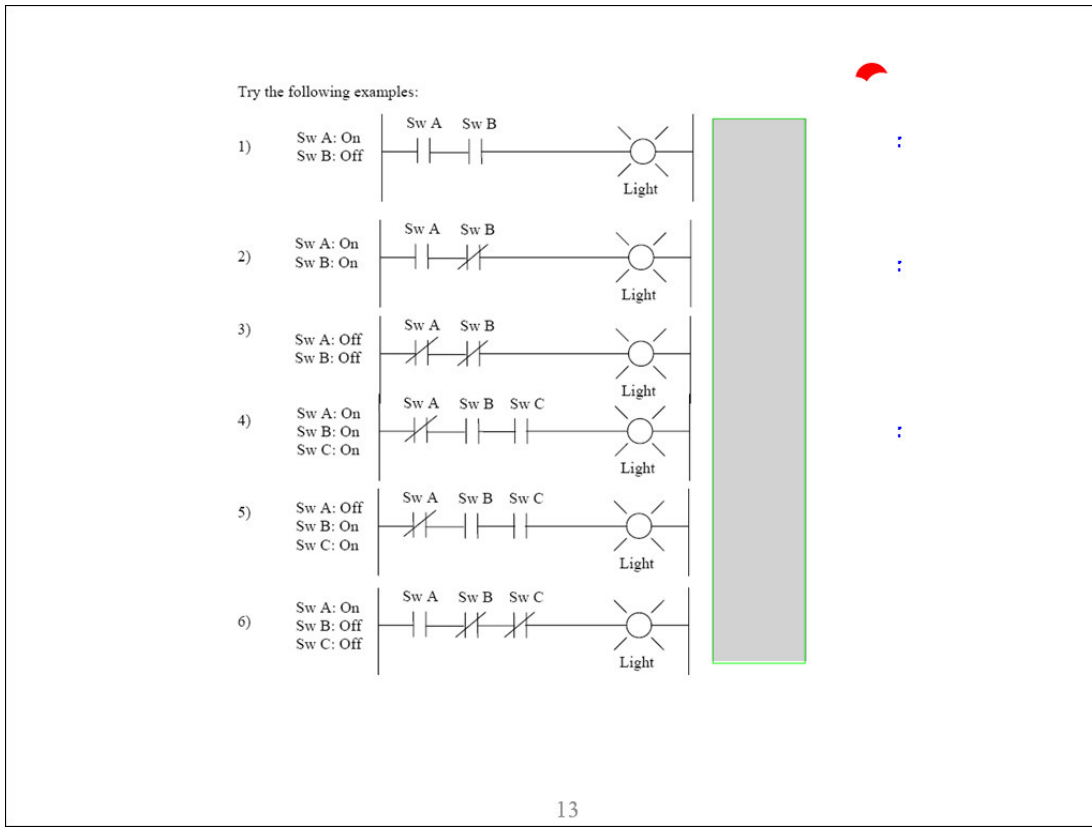

Panel 14

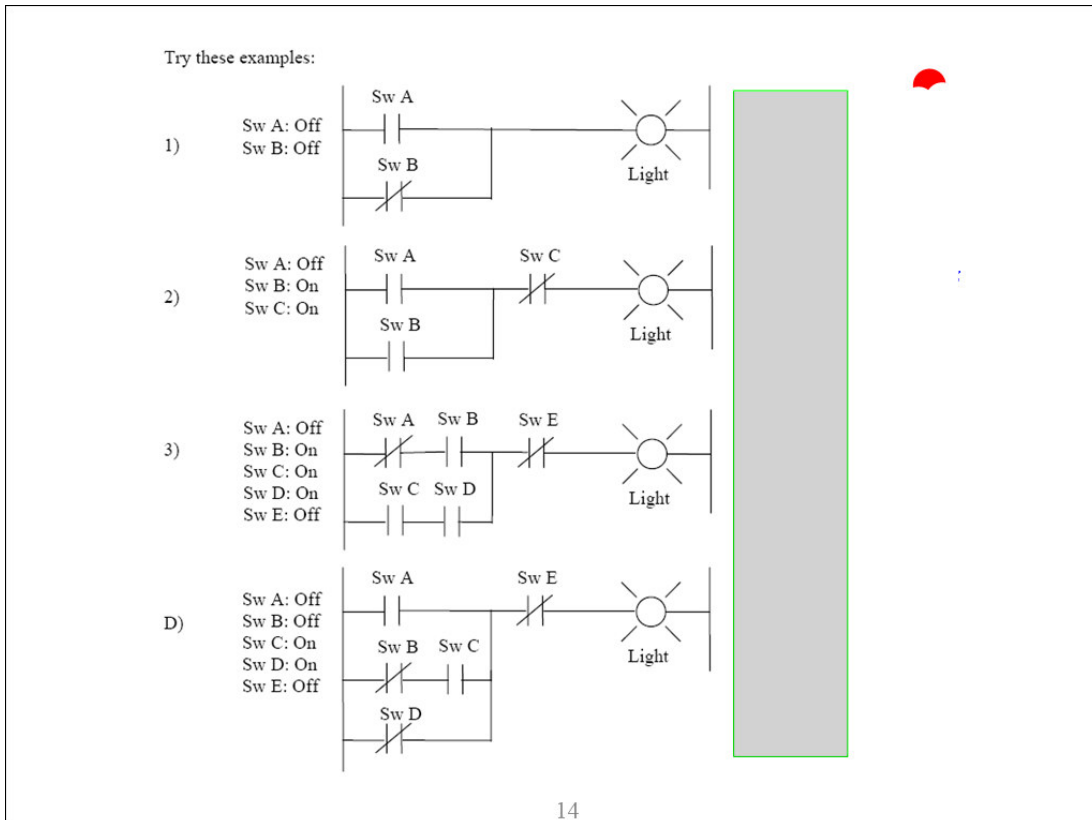

Panel 15

**Boolean Logic as Ladder Logic:**

**Logical OR:** Two switches in parallel

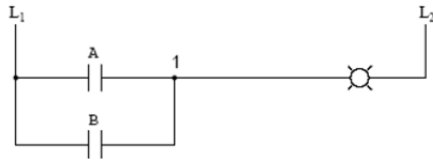

A	B	Output
0	0	0
0	1	1
1	0	1
1	1	1

**Logical AND:** Two switches in series

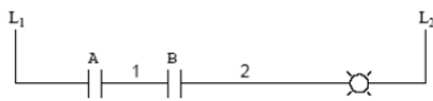

A	B	Output
0	0	0
0	1	0
1	0	0
1	1	1

**Logical NOT:** Use of a Normally Closed switch

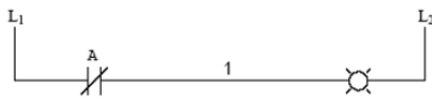

A	Output
0	1
1	0

Panel 16

**Designing ladder logic circuits**

I like to start with a table to organize my plan

**Example:**

- Switch A is a N.O. momentary switch
- Switch B is a N.C. momentary switch
- Switch C is a N.O. position switch

	Made	Broken
Switch A		
Switch B		
Switch C		

Panel 17

Let's make a circuit that turns on the output when all three switches are pressed...

