

**Problem 4.86**

The mechanism moves in the horizontal plane. Massless rods  $AB$  and  $AC$  are pinned together at  $A$  and pinned to collars at  $A$ ,  $B$ , and  $C$ . Smooth square pins keep collars  $A$ ,  $B$  and  $C$  aligned with the slots. If a  $100\text{N}$  force  $F$  is applied to  $B$  as shown **find** the linear velocities of collars  $A$ ,  $B$  and  $C$  when rod  $AB$  is aligned with the horizontal slot and rod  $AC$  is aligned with the  $30$  degree inclined slot.  $m_A = 5\text{kg}$ ,  $m_B = 3\text{kg}$ , and  $m_C = 2\text{kg}$ . (Working model 'square pin in slot' rather than collar over rod is provided to help interpretation.)

Initial

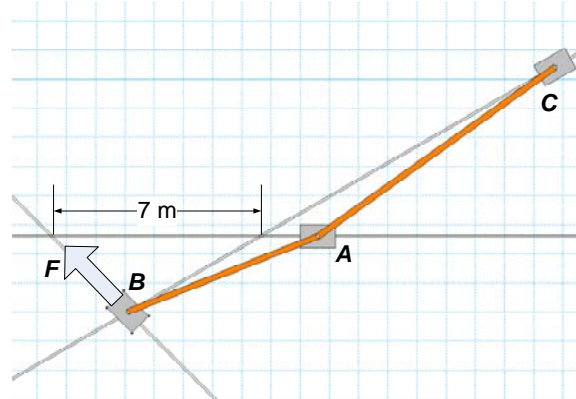

Final:

