

Problems

Problem 3.1

A 2700-lb automobile starts from rest and travels a quarter of a mile. Assume that the coefficient of static friction between the tires and the pavement is 0.70, the automobile has front-wheel drive, the front wheels support 62% of the automobile's weight, and air resistance must be considered where the aerodynamic drag D has a magnitude $D = 0.012 v^2$, where D and v are expressed in pounds and ft/s, respectively. (a) Determine the maximum theoretical speed. (b) Plot the maximum speed as a function of the coefficient of static friction over the domain $0.3 < \mu_s < 0.9$. Note: The word "plot" means to use appropriate software and not a sloppy hand sketch!

Problem 3.2

The velocities of commuter trains A and B are as shown. The speed of each train is constant and B reaches the crossing 10 min after A passed through the same crossing. Determine a) the relative velocity of B with respect to A and b) the distance between the fronts of the engines 3 min after A passed through the crossing.

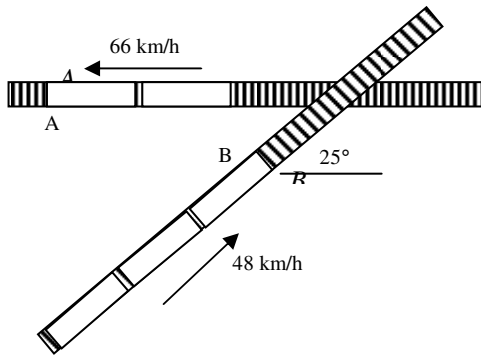

Problem 3.3

A conveyor belt A, which forms a 20° angle with the horizontal, moves at a constant speed of $v_A = 4$ ft/s and is used to load an airplane. A worker tosses duffel bag B with an initial velocity of $(v_B)_0 = 2.5$ ft/s at an angle of 30° with the horizontal. Assume the bag does not rotate. Determine the velocity of the bag relative to the belt as it lands on the belt.

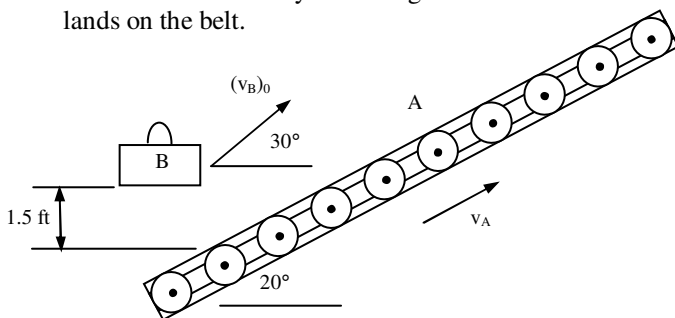

Problem 3.4

The masses of blocks A, B, and C are $m_A = 4$ kg, $m_B = 10$ kg, and $m_C = 2$ kg. Neglect the masses of the pulleys and the effect of friction. Assuming the blocks are released from rest, determine a) the acceleration of each block, b) the tension in the cord and c) the distance block A will travel in 2 seconds.

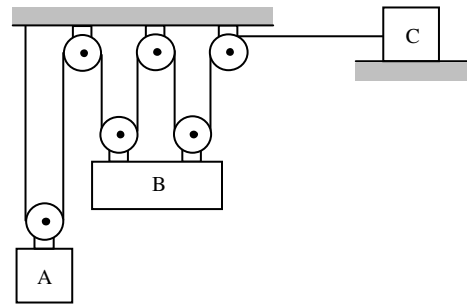

Problem 3.5

Block B has a mass of 10 kg and rests on the upper surface of a 22-kg wedge, A, as shown. The system is released from rest and friction is negligible. Determine a) the acceleration of B, and b) the velocity of B relative to A at $t = 0.5$ s.

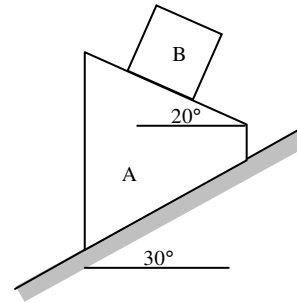

Problem 3.6

During a high-speed chase, a 2400-lb sports car traveling at a speed of 100 mi/h just loses contact with the road as it reaches the crest A of a hill. a) Determine the radius of curvature ρ of the vertical profile of the road at A. b) Using the value of ρ found in a part a), determine the force exerted on a 160-lb driver by the seat of his 3100-lb car as the car, traveling at a constant speed of 50 mi/h, passes through A.

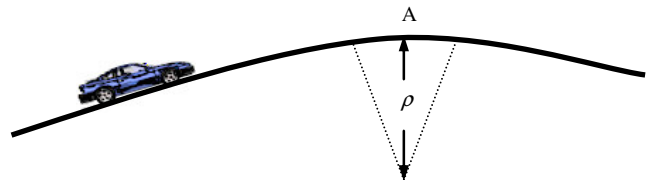

Problem 3.7

A small block slides at a speed $v = 8$ ft/s on a horizontal surface at a height $h = 3$ ft above the ground. Determine a) the angle θ at which it will leave the cylindrical surface BCD and b) the distance x at which it will hit the ground. Neglect friction and air resistance.

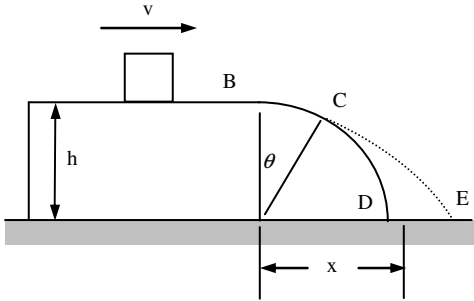

Problem 3.8

A thin circular rod is supported in a vertical plane by a bracket at A. Attached to the bracket and loosely wound around the rod is a spring of constant $k = 3$ lb/ft and undeformed length equal to the arc AB . An 8-oz collar is unattached to the spring and can slide without friction along the rod. The collar is released from rest when $\theta = 30^\circ$. Determine, a) the velocity of the collar as it passes through point B, b) the force exerted by the rod on the collar as it passes through B, and c) plot the velocity of the collar as it passes through point B as a function of the initial angle, θ , over $15^\circ < \theta < 45^\circ$.

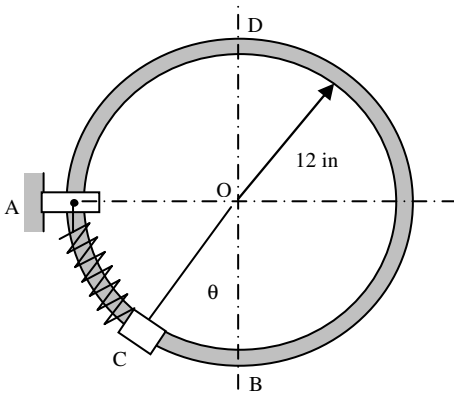

Problem 3.9

The rotation of rod OA about O is defined by the relation $\theta = \pi(4t^2 - 8t)$, where θ and t are expressed in radians and seconds, respectively. Collar B slides along the rod so that its distance from O is $r = 10 + 6 \sin \pi t$, where r and t are expressed in inches and seconds, respectively. When $t = 1.2$ s, determine: a) velocity of the collar in radial and transverse components, b) acceleration of the collar in radial and transverse components, c) plot the path of collar B from $t = 0$ to $t = 1.25$ s using the following Maple commands (you need to type this all on one line):

```
plot([ [10+6*sin(Pi*1.2), Pi*(4*1.2^2-8*1.2)], t=1.2..1.2], [10 + 6*sin(Pi*t), Pi*(4*t^2-8*t)], t=0..1.25], style=[point, line], symbol=[circle, point], coords=polar, color=[red, blue], symbolsize=[18, 1], scaling=constrained);
```

This command will plot the trajectory and place a circle when $t = 1.2$ s. d) Print out the plot and draw the velocity vector and its components on the Maple plot at $t = 1.2$ s.

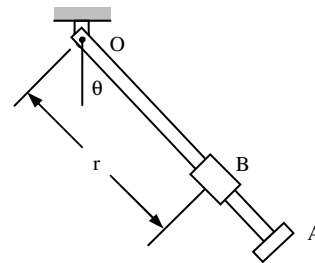

Problem 3.10

The flight path of airplane B is a horizontal straight line that passes directly over a radar tracking station at A. The airplane moves to the left with the constant velocity v_0 . Determine $d\theta/dt$ and $d^2\theta/dt^2$ in terms of v_0 , h , and θ .

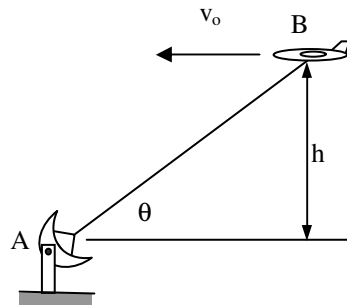

Problem 3.11

The disk A rotates in a horizontal plane about a vertical axis at a constant rate of $\dot{\theta}_o = 15 \text{ rad/s}$. Slider B weighs 8 oz and moves in a frictionless slot cut in the disk. The slider is attached to a spring of constant $k = 4 \text{ lb/ft}$, which is undeformed when $r = 0$. Knowing that the disk is released with a zero radial component of velocity when $r = 1 \text{ ft}$, determine the velocity and the normal force between the slider and the slot when $r = 0.5 \text{ ft}$.

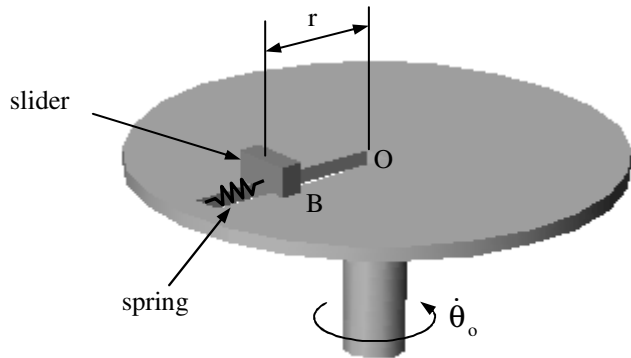

Problem 3.12

Two identical cars A and B are at rest on a loading dock with brakes released. Car C, has been pushed by dockworkers and hits car B with a velocity of 1.5 m/s. Knowing that all the cars weigh the same and that the coefficient of restitution is 0.8 between B and C and 0.5 between A and B, determine the velocity of each car after all collisions have taken place.



Problem 3.13

A 1.3 lb sphere A is dropped from a height of 1.8 ft onto a 2.6 lbf plate B, which is supported by a nested set of springs and is initially at rest. Knowing that the coefficient of restitution between the sphere and the plane is $e = 0.8$, determine a) the height, h , reached by the sphere after rebound, b) the equivalent spring constant for the set of springs if the maximum deflection of the plate is observed to be $3h$.

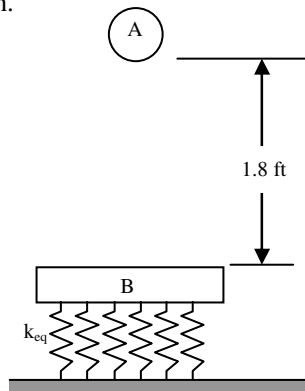

Problem 3.14

A 70-g ball B is given an initial velocity, v_o , as shown. The ball reaches a height $h_2 = 0.25 \text{ m}$ after bouncing twice from identical 210-g plates. Plate A rests directly on the hard ground, while plate C rests on a foam-rubber mat. Determine a) the coefficient of restitution between the ball and the plates, b) the height h_1 of the ball's first bounce.

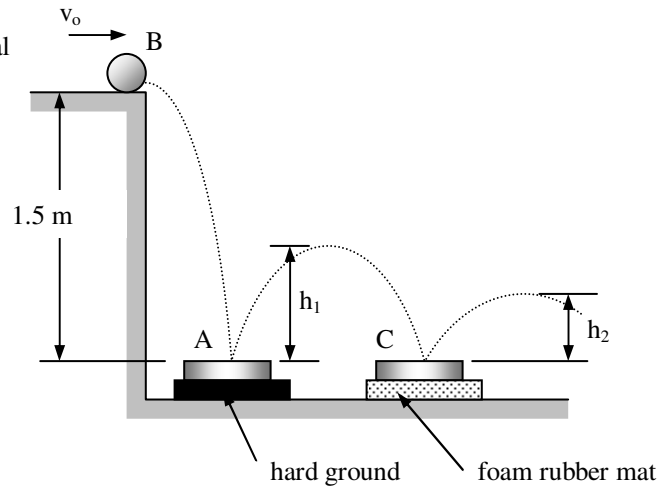

Problem 3.15

Two identical hockey pucks are moving on a hockey rink at the same speed of 3 m/s and in parallel and opposite directions when they strike each other. Assuming a coefficient of restitution of 0.9, determine the magnitude and direction of the velocity of each puck after impact.

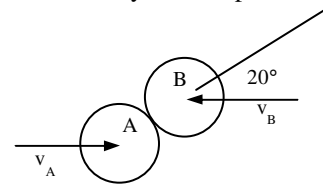

Problem 3.16

A 700-g sphere A moving with a velocity v_o parallel to the ground strikes the inclined face of a 2.1-kg wedge B which can roll freely on the ground and is initially at rest. After impact the sphere is observed from the ground to be moving straight up. Knowing that the coefficient of restitution between the sphere and the wedge is $e = 0.6$, determine a) the angle, θ , that the inclined face of the wedge makes with the horizontal, b) the energy lost due to the impact, and c) the impulse acting between the ground and the wedge B during the impact.

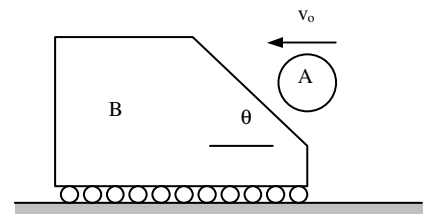

Problem 3.17

The greatest ocean depth yet discovered is in the Marianas Trench in the western Pacific Ocean. A 29 lb steel ball released at the surface requires 64 minutes to reach the bottom. The ball's experiences a drag force equal to $D = 3.02 v$ where $c = 3.02$ lb-s/ft and v is the speed of the ball. What is the depth of the Marianas Trench in miles?

Problem 3.17b

A boat is moving to the right with a constant deceleration of 0.3 m/s^2 when a boy standing on the deck D throws a ball with an initial velocity relative to the deck which is vertical. The ball rises to a maximum height of 8 m above the release point and the boy must step forward a distance d to catch it at the same height as the release point.

Determine (a) the distance d , (b) the relative velocity of the ball with respect to the deck when the ball is caught.

Problem 3.18

The masses of blocks A, B, and C are $m_A = 4 \text{ kg}$, $m_B = 10 \text{ kg}$, and $m_C = 2 \text{ kg}$. Neglect the masses of the pulleys and the effect of friction. Assuming the blocks are released from rest, determine a) the acceleration of each block, b) the tension in the cords and c) the distance block A will travel in 2 seconds.

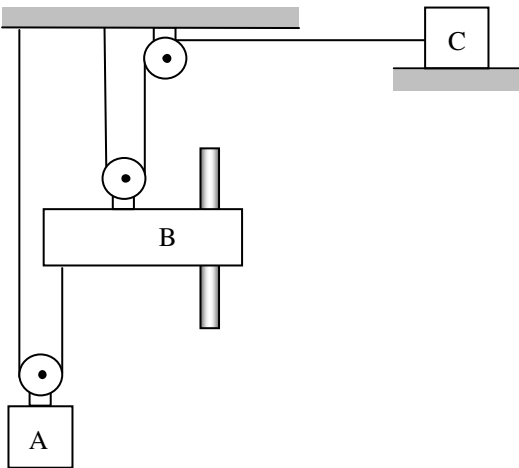

Problem 3.19

Block B has a mass 10 kg and rests on the upper surface of a 20-kg wedge, A, as shown. The system is released from rest and friction is negligible. Determine a) the acceleration of B, and b) the velocity of B relative to A at $t = 0.5 \text{ s}$.

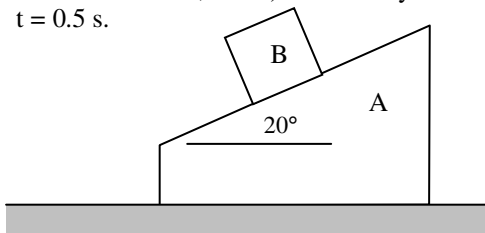

Problem 3.20

It is desired to have the package shown deposited on the horizontal surface with a speed horizontal surface with a speed of 1.5 m/s. Knowing that $r = 0.3 \text{ m}$, (a) determine the required initial speed v_0 when the first loop is used, (b) show that this requirement cannot be fulfilled by the second loop, (c) determine the smallest v_0 so that the package will be deposited on the horizontal surface when the second loop is used.

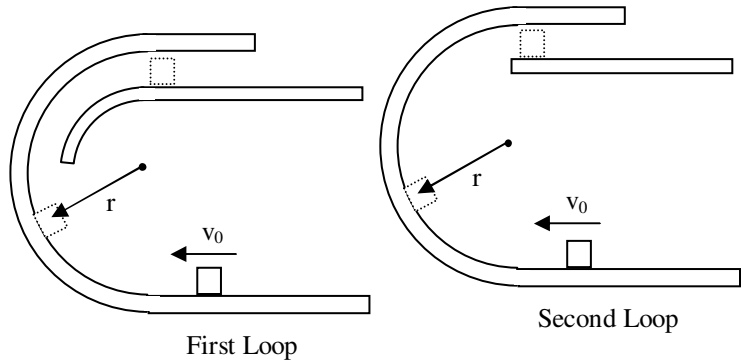

Problem 3.21

A 3-lb collar is attached to a spring and slides without friction along a circular rod in a horizontal plane. The spring has an undeformed length of 6 in. and a constant $k = 1.5 \text{ lb/in}$. Knowing that the collar is in equilibrium at A and is given a slight push to get it moving, determine the velocity of the collar (a) as it passes through B, (b) as it passes through C, (c) the normal force between the rod and the collar at C.

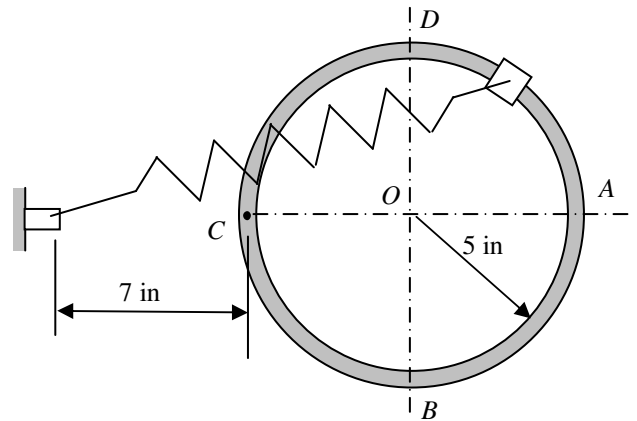

Problem 3.22

To study the performance of a race car, a high speed camera is positioned at A. The camera is mounted on a mechanism which permits it to record the motion of the car as the car travels on straightaway BC. Determine the speed and the magnitude of the acceleration in terms of b , θ , $\dot{\theta}$, and $\ddot{\theta}$.

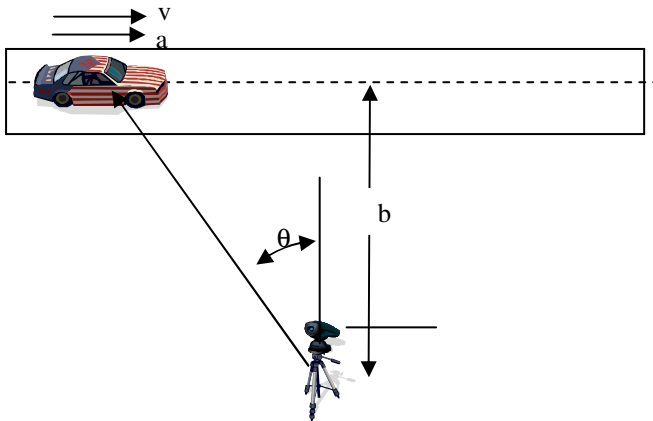

Problem 3.23

A 0.25-lb ball thrown with a horizontal velocity \mathbf{v}_0 strikes a 1.5-lb plate attached to a vertical wall at a height of 36 in. above the ground. It is observed that after rebounding, the ball hits the ground at a distance of 24 in. from the wall when the plate is rigidly attached to the wall (Fig. 1), and at a distance of 10 in. when a foam-rubber mat is placed between the plate and the wall (Fig. 2). Determine (a) the coefficient of restitution e between the ball and the plate, (b) the initial velocity \mathbf{v}_0 of the ball.

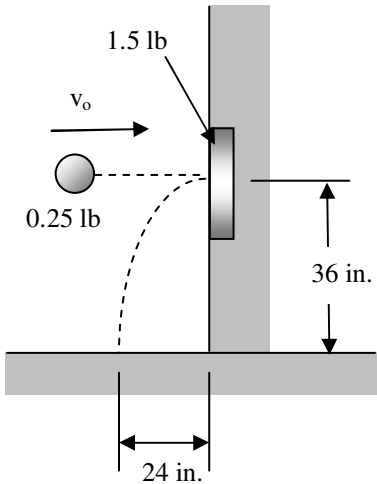

Figure 1

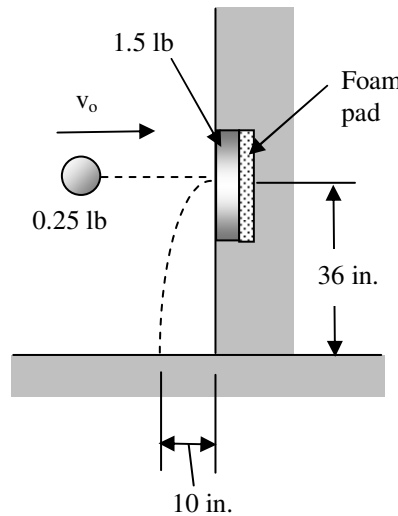
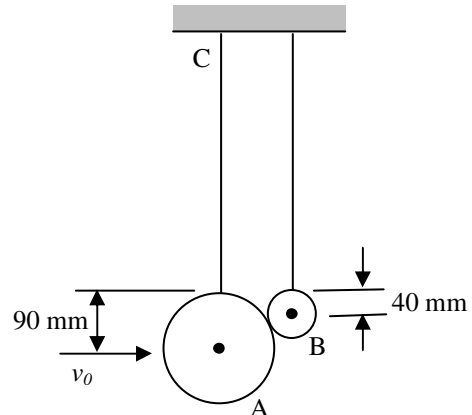

Figure 2

Answer: $e = 0.324$, $v_0 = 14.3$ ft/s

Problem 3.24

A 7.92-kg sphere A of radius 90 mm moving with a velocity \mathbf{v}_0 of magnitude $v_0 = 2$ m/s strikes a 720-g sphere B of radius 40 mm which was at rest. Both spheres are hanging from identical light flexible cords. Knowing that the coefficient of restitution is 0.8, determine a) the velocity of each sphere immediately after impact b) the impulses in the cables during the impact.



Answers: $v'_A = 1.741$ m/s, $v'_B = 3.08$ m/s
 $T_A \Delta t = 0.854$ N-s, $T_B \Delta t = 0$ (it will go slack)

Problem 3.25

Block A slides down the incline and strikes sphere B causing it to swing up. The tension in the cable is 100 N immediately after the impact. Assume the mass of A, m_A , the mass of B, m_B , the coefficient of restitution, e , the coefficient of friction, μ_k , and the distance, d , are all known.

- a) Determine the equations necessary to determine the initial velocity of A, v_0 . Neglect the friction between A and B during the impact.
- b) If $m_A = 1 \text{ kg}$, $m_B = 0.5 \text{ kg}$, $e = 0.6$, $\mu_k = 0.35$, $L = 1.2 \text{ m}$ and $d = 1.4 \text{ m}$, determine the initial velocity of A, v_0

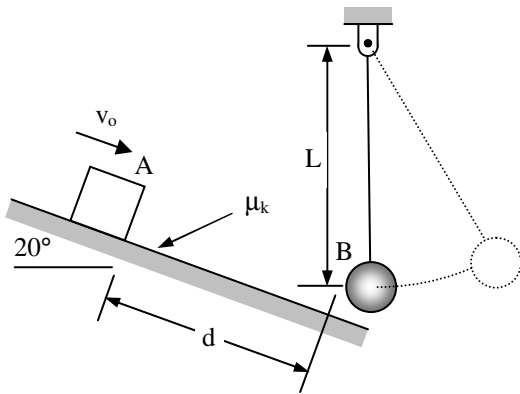

Problem 3.26

In the lab you are to design a device for launching a projectile a maximum distance. This homework problem is intended to help you in your design.

- a) What is the maximum theoretical velocity the projectile may have assuming all of the gravitational energy of the falling block is transferred to the projectile?
- b) Assuming the projectile is launched with a velocity v_0 from an elevation, h , as shown, determine the optimum angle, θ , so that the distance, d , is maximized.
- c) Using the velocity you found in part a) and using $h = 10 \text{ m}$, determine the angle, θ , in degrees and the distance, d .
- d) Using your result from part d) what is the radius of curvature of the path of the particle immediately after it is launched and at its maximum elevation?

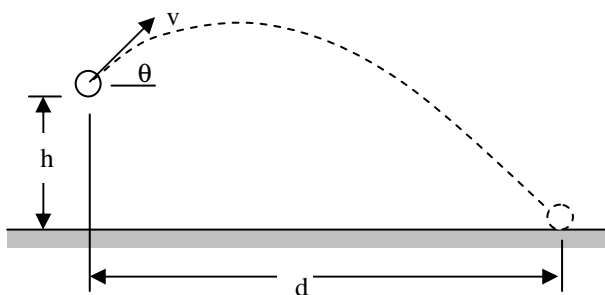

Problem 3.27

The suspended 10 pound object is initially stationary. The length of string B is 1.5 ft.

- (a) What are the tensions in the strings?
- (b) If string A is cut, what is the tension in string B immediately afterwards?
- (c) What is the tension in string B after the mass falls to the point where the string is vertical, that is, the angle shown in the figure is 90 degrees.

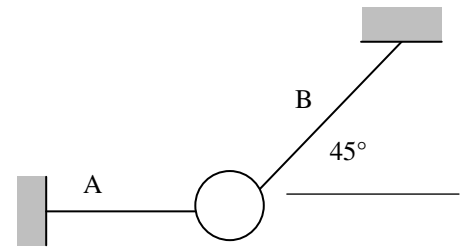

Problem 3.28 (modified from Bedford and Fowler)

A skydiver is falling vertically at 90 ft/s when his parachute opens. The skydiver and his parachute weigh 220 lb. When the parachute opens the magnitude of the upward force is $0.3 v^2$. Determine:

- a) The magnitude of his acceleration when the parachute first opens
- b) The magnitude of his velocity after he has descended 100 ft from the point where his parachute opens.



Problem 3.29 (modified from Bedford and Fowler)

Relative to the earth a pirate ship sails north at a velocity v_0 and then sails east at the same velocity. The velocity of the wind is uniform and constant. The flag on the boat points in the direction of the velocity of the wind relative to the boat. What are the magnitude and direction of the wind's velocity relative to the earth?

Hint: The magnitude of the relative velocities in the two cases are unknown.

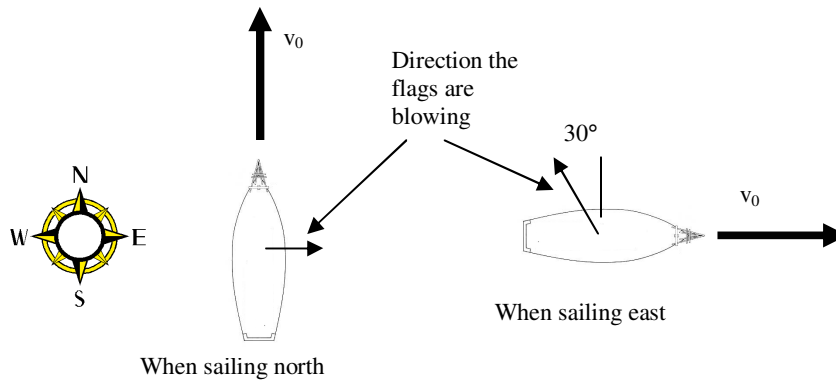

Problem 3.30 (modified from Beer and Johnston)

The conveyor belt A moves with a constant velocity and discharges sand onto belt B as shown. Knowing the velocity of the belt at B is 8 ft/s and the velocity of the belt at A is 6 ft/s, determine the velocity of the sand relative to the belt B as it lands on belt B.

