

ECE-520: Linear Control Systems
Homework 5

Due: Thursday January 12 at 5 PM **Exam 1, Monday January 23 in Class**

1) Consider the following state variable system

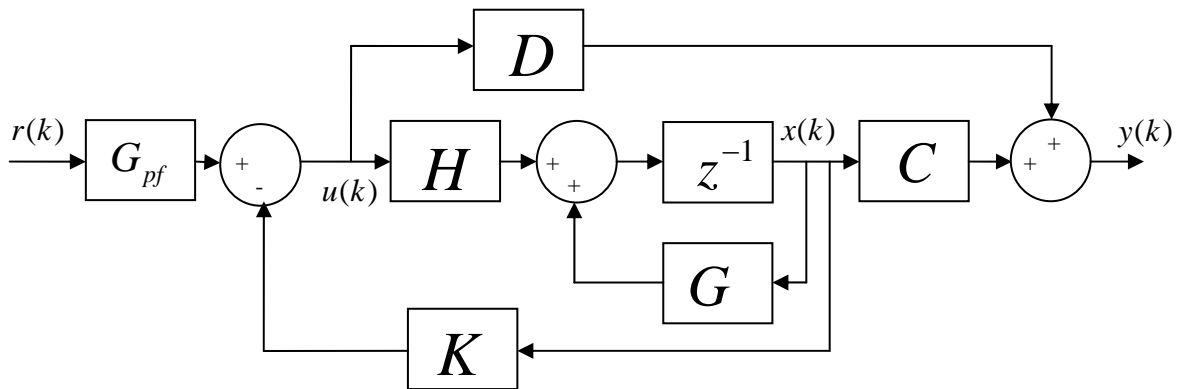

Here G_{pf} is the prefilter gain, $r(k)$ is the reference input, and $K = [k_1 \quad k_2]$ is the feedback gain matrix. The state variable model for the plant is assumed to be

$$\begin{aligned} x(k+1) &= Gx(k) + Hu(k) \\ y(k) &= Cx(k) + Du(k) \end{aligned}$$

From the diagram we have $u(k) = G_{pf}r(k) - Kx(k)$.

a) Determine an expression for the transfer function between the input $R(z)$ and the output $Y(z)$.

b) Assuming $D = 0$ and using the Final Value Theorem, show that for a single input single output system to have a zero steady state error for a unit step input we need to choose the prefilter to be

$$G_{pf} = \frac{1}{C(I - G + HK)^{-1}H}$$

Hint: In order to have a zero steady state error for a unit step input, the final value of the output, $y(\infty) = y_{ss}$, should be 1.

2) Consider the discrete-time state variable model

$$\underline{x}(k+1) = G\underline{x}(k) + Hu(k)$$

with the initial state $x(0) = 0$. Let

$$G = \begin{bmatrix} 0 & 1 \\ 1 & 0 \end{bmatrix}, H = \begin{bmatrix} 1 \\ 1 \end{bmatrix}, C = [1 \quad 0], D = 0$$

a) Determine the corresponding transfer function for the system.

b) After 1 time step we have $x(1) = Hu(0) = Mu(0)$ so $M = H$. After 2 time steps we have

$$x(2) = Gx(1) + Hu(1) = GHu(0) + Hu(1) = \begin{bmatrix} GH & H \end{bmatrix} \begin{bmatrix} u(0) \\ u(1) \end{bmatrix} = M\tilde{u}(1)$$

so $M = \begin{bmatrix} GH & H \end{bmatrix}$ and $\tilde{u}(1) = [u(0) \quad u(1)]^T$. Now assume we want $x(2) = [1 \quad 0]^T$. Can you find an input vector $\tilde{u}(1)$, and hence input values $u(0)$ and $u(1)$, to make this happen? If you cannot go from the origin to any possible state in at most n steps, where $x(k) \in \mathbb{R}^n$, then the system is not controllable. Why at most n steps? See below.....

c) The **Cayley-Hamilton Theorem** from Linear Algebra states that *a matrix satisfies its own characteristic equation*. The characteristic equation of a matrix G is found by setting the determinant of $W = zI - G$ equal to zero. Show that the characteristic equation for our system is given by $z^2 - 1 = 0$ and then verify that $G^2 - I = 0$.

d) Now let's look at the third time step

$$x(3) = Gx(2) + Hu(2) = G^2Hu(0) + GHu(1) + Hu(2)$$

Using the Cayley-Hamilton Theorem, we can write $G^2 = I$. Show that we can then write

$$x(3) = \begin{bmatrix} GH & H \end{bmatrix} \tilde{u}(2)$$

$$\tilde{u}(2) = [u(1) \quad u(2) + u(0)]^T$$

e) Show that we can write

$$x(4) = \begin{bmatrix} GH & H \end{bmatrix} \tilde{u}(3)$$

$$\tilde{u}(3) = [u(0) + u(2) \quad u(1) + u(3)]^T$$

At this point, it should be clear that if we cannot find an input to go from the origin to a particular final state in $n = 2$ steps for a second order system we never will be able to get there, no matter how long we let the system run. If $x \in \mathbb{R}^n$, then the controllability matrix is defined to be $M = \begin{bmatrix} G^{n-1}H & G^{n-2}H & \dots & GH & H \end{bmatrix}$. For a system to be controllable, this matrix must have rank n , or, equivalently, n linearly independent columns (or rows).

f) Now assume we are using state variable feedback with a prefilter gain G_{pf} , so

$u(k) = G_{pf}r(k) - Kx(k)$. Here $r(k)$ is the reference input and $K = [k_1 \quad k_2]$ is the feedback gain matrix. With this form of state variable feedback, we have the system

$$x(k+1) = Gx(k) + H[G_{pf}r(k) - Kx(k)] = [G - HK]x(k) + [HG_{pf}]r(k)$$

or

$$x(k+1) = \tilde{G}x(k) + \tilde{H}r(k)$$

Note that now the system input is the reference input $r(k)$. Show that for $D = 0$ the transfer matrix is given by

$$F(z) = \frac{Y(z)}{R(z)} = C(zI - \tilde{G})^{-1}\tilde{H} = \frac{G_{pf}(z+1)}{(z+k_1)(z+k_2) - (k_1-1)(k_2-1)}$$

g) Show that if $G_{pf} = 1$ and $k_1 = k_2 = 0$, the transfer function reduces to that found in part **a**.

h) Is it possible to find k_1 and k_2 to place the poles of the closed loop system where ever we want? For example, can we make both poles be zero?

In summary, if the system is controllable

- *We can go from the origin to any final state in n steps (the rank of the controllability matrix M is n)*
- *We can place the poles of the closed loop system anywhere we want using state variable feedback*

3) Consider the discrete-time state variable model

$$\underline{x}(k+1) = G\underline{x}(k) + Hu(k)$$

with the initial state $x(0) = 0$. Let

$$G = \begin{bmatrix} 1 & 0 \\ 1 & 1 \end{bmatrix}, H = \begin{bmatrix} 0 \\ 1 \end{bmatrix}, C = [0 \quad 1], D = 0$$

a) Determine the corresponding transfer function for the system.

b) Find the M matrix after two time steps. Now assume we want $x(2) = [1 \quad 1]^T$. Can you find an input vector $\tilde{u}(1)$, and hence input values $u(0)$ and $u(1)$, to make this happen?

c) Show that the characteristic equation for G is given by $z^2 - 2z + 1 = 0$ and verify that $G^2 = 2G - I$.

d) Show that we can then write

$$x(3) = [GH \quad H]\tilde{u}(2)$$

$$\tilde{u}(2) = [2u(0) + u(1) \quad u(2) - u(0)]^T$$

e) Show that we can write

$$x(4) = [GH \quad H]\tilde{u}(3)$$

$$\tilde{u}(3) = [3u(0) + 2u(1) + u(2) \quad -2u(0) - u(1) + u(3)]^T$$

f) Now assume we are using state variable feedback with $u(k) = G_{pf}r(k) - Kx(k)$. Show that for $D=0$ the transfer matrix is given by

$$F(z) = \frac{Y(z)}{R(z)} = \frac{G_{pf}(z-1)}{(z-1)(z+k_2-1)}$$

g) Show that if $G_{pf} = 1$ and $k_1 = k_2 = 0$, the transfer function reduces to that found in part **a**.

h) Is it possible to find k_1 and k_2 to place the poles of the closed loop system where ever we want? For example, can we make both poles be zero?

4) Consider the discrete-time state variable model

$$\underline{x}(k+1) = G\underline{x}(k) + Hu(k)$$

with the initial state $x(0) = 0$. Let

$$G = \begin{bmatrix} 0 & 1 \\ 1 & 1 \end{bmatrix}, H = \begin{bmatrix} 0 \\ 1 \end{bmatrix}, C = [1 \quad 0], D = 0$$

a) Determine the corresponding transfer function for the system.

b) Find the M matrix after two time steps. Now assume we want $x(2) = [1 \quad 0]^T$. Can you find an input vector $\tilde{u}(1)$, and hence input values $u(0)$ and $u(1)$, to make this happen? Now assume we want $x(2) = [0 \quad 1]^T$. Can you find an input vector $\tilde{u}(1)$ to make this happen?

c) Show that the characteristic equation for G is given by $z^2 - z - 1 = 0$ and verify that $G^2 = G + I$.

d) Show that we can then write

$$x(3) = [GH \quad H]\tilde{u}(2)$$

$$\tilde{u}(2) = [u(0) + u(1) \quad u(0) + u(2)]^T$$

e) Show that we can write

$$x(4) = [GH \quad H]\tilde{u}(3)$$

$$\tilde{u}(3) = [2u(0) + u(1) + u(2) \quad u(0) + u(1) + u(3)]^T$$

f) Now assume we are using state variable feedback with $u(k) = G_{pf}r(k) - Kx(k)$. Show that for $D = 0$ the transfer matrix is given by

$$F(z) = \frac{Y(z)}{R(z)} = \frac{G_{pf}}{z^2 + (k_2 - 1)z + (k_1 - 1)}$$

g) Show that if $G_{pf} = 1$ and $k_1 = k_2 = 0$, the transfer function reduces to that found in part **a**.

h) Is it possible to find k_1 and k_2 to place the poles of the closed loop system where ever we want? For example, can we make both poles be zero? If we want the poles to be at p_1 and p_2 show that $k_1 = 1 - (p_1 + p_2)$ and $k_2 = 1 + p_1p_2$.

5) For the discrete-time state variable system given by

$$x(k+1) = \begin{bmatrix} 0 & 1 \\ 1 & 1 \end{bmatrix} x(k) + \begin{bmatrix} 0 \\ 1 \end{bmatrix} u(k)$$
$$y(k) = \begin{bmatrix} 1 & 0 \end{bmatrix} x(k)$$

a) Assuming state variable feedback, find a state variable feedback matrix K to place the closed loop poles at 0 and 0.1.

b) Find a state variable feedback matrix K that will result in deadbeat control.

c) Using the value of K determined in part **b**, determine the correct value of prefilter gain G_{pf} so the steady state error for a unit step is zero.

6) For the discrete-time state variable system given by

$$x(k+1) = \begin{bmatrix} 0.1 & 0 \\ 0.2 & -0.1 \end{bmatrix} x(k) + \begin{bmatrix} 0.1 \\ 0 \end{bmatrix} u(k)$$
$$y(k) = \begin{bmatrix} 1 & 1 \end{bmatrix} x(k)$$

a) Assuming state variable feedback, find a state variable feedback matrix K to place the closed loop poles at 0 and 0.1.

b) Find a state variable feedback matrix K that will result in deadbeat control.

c) Using the value of K determined in part **b**, determine the correct value of prefilter gain G_{pf} so the steady state error for a unit step is zero. *Feel free to use a computer on this part.*

Preparation for Lab 5 (to be done individually)

7) The one degree of freedom discrete –time Simulink model **DT_sv1.mdl** implements a state variable model with state feedback. This model uses the Matlab code **DT_sv1_driver.m** to drive it. Both of these programs are available on the course website. The blue and yellow blocks represent the model of the system which will be replaced with the ECP driver/real system in lab.

- a) Load your one degree of freedom *rectilinear* model that was obtained by discretizing your continuous time model.
- b) Modify the Matlab code (the poles and the **place** command) to place the poles of the closed loop system in such a way so that for a 1 cm step input:
 - the settling time for your system is less than 1 s
 - the percent overshoot for your system is less than 20%
 - the control effort does not hit a limiter (does not saturate)
 - the steady state error is zero
- c) Simulate the system and turn in your graph.
- d) Modify the Matlab code so your system has deadbeat response, if possible. You may need to use the **Acker** command instead of **place** to do this.

8) Copy **DT_sv1.mdl** and **DT_sv1_driver.m** to **DT_sv2.mdl** and **DT_sv2_driver.m**, respectively, and then modify the new files to work with a two degree of freedom system. All of the states except the last (delayed input) state must be plotted, as well as the control effort and the output state (y). Assume we want to control the position of the second cart (You may have to change the C matrix to do this.) Then

- a) Load your two degree of freedom *rectilinear* model that was obtained by discretizing your continuous time model.
- b) Modify the Matlab code (the poles and the **place** command) to place the poles of the closed loop system in such a way so that for a 1 cm step input:
 - the settling time for your system is less than 1 s
 - the percent overshoot for your system is less than 20%
 - the control effort does not hit a limiter (does not saturate)
 - the steady state error is zero
- c) Simulate the system and turn in your graph.
- d) Modify the Matlab code so your system has deadbeat response, if possible. You may need to use the **Acker** command instead of **place** to do this.