

ECE-520: Discrete-Time Control Systems
Homework 1

Due: Tuesday December 5 at the beginning of class

1) Using the fact that $e^a = \sum_{k=0}^{\infty} \frac{a^k}{k!}$, find the z transform of

a) $f(k) = \frac{\gamma^k}{k!} u(k)$

b) $f(k) = \frac{(\ln(\gamma))^k}{k!} u(k)$

(Answers: $F(z) = e^{\frac{z}{\gamma}}$, $F(z) = \gamma^{\frac{1}{z}}$)

2) For the z -transform

$$X(z) = \frac{3}{z-2}$$

a) Show that, by multiplying and dividing by z and then using partial fractions, the corresponding discrete-time sequence is

$$x(k) = -\frac{3}{2} \delta(k) + \frac{3}{2} 2^k u(k)$$

b) By starting with the z -transform

$$Y(z) = \frac{3z}{z-2}$$

and the z -transform properties, show that

$$x(k) = 3 \cdot 2^{k-1} u(k-1)$$

3) For a system with a real simple pole at $-\sigma$ we have

$$H(s) = \frac{1}{s+\sigma} \leftrightarrow h(t) = e^{-\sigma t} u(t)$$

a) Show that if we sample $h(t)$ with a sampling interval T , so $h(kT) = e^{-\sigma kT} u(k)$, then we have

$$H(z) = \frac{z}{z - e^{-\sigma T}}$$

b) For a continuous time system, if we want the (2 %) settling time to be T_s , then we need

$\frac{4}{\sigma} < T_s$, where σ is magnitude of the real part of the dominant pole (this controls the

decay rate of the system). Show that for our simple pole (sampled) system this would require our poles to have magnitudes less than e^{-4T/T_s} , or

$$r < e^{-4T/T_s}$$

where r is the magnitude of the pole and T_s is the desired settling time.

- c) For a fixed settling time, as the sampling interval increases, will the required magnitudes of the poles decrease or increase?
- d) Choose two different values of T and T_s , then determine complex poles that match the conditions in part b. Show that these characteristic functions associated with these poles have the desired settling time.
- e) Assume we have a system with a simple pole with impulse response $h(k) = a^k u(k)$. If we want the system to reach its (2%) settling time in 4 samples, what are the restrictions on the magnitude of a ?

4) Consider the following difference equation

$$x(k+2) - 4x(k+1) + 4x(k) = f(k)$$

Assume all initial conditions are zero.

- a) Determine the impulse response of the system, i.e., the response $x(k)$ when $f(k) = \delta(k)$.
- b) Determine $x(0)$, $x(1)$, $x(2)$, $x(3)$, and $x(4)$ from your answer to a. Compare this answer with the known values of $x(0)$ and $x(1)$. Using the difference equation compute $x(3)$ and $x(4)$ and compare these values to those in your solution.
- c) Determine the step response of the system, i.e., the response $x(k)$ when $f(k) = u(k)$
- d) Determine $x(0)$, $x(1)$, $x(2)$, $x(3)$, and $x(4)$ from your answer to c. Compare this answer with the known values of $x(0)$ and $x(1)$. Using the difference equation compute $x(3)$ and $x(4)$ and compare these values to those in your solution.

5) Consider the difference equation

$$x(k+2) - 4x(k+1) + 4x(k) = f(k+1)$$

where $f(k) = u(k)$, a unit step. Assume $x(0) = 0$ and $x(1) = 1$. Sometimes we are interested in writing the solution in two parts, which we will do here.

- a)** Determine the Zero Input Response (ZIR), $x_{ZIR}(k)$. This is the part of the solution $x(k)$ due to the initial conditions alone (assume the input is zero).
- b)** Determine the Zero State Response (ZSR), $x_{ZSR}(k)$. This is the part of the solution $x(k)$ due to the input alone (assume all initial conditions are zero).
- c)** Find the total response $x(k) = x_{ZIR}(k) + x_{ZSR}(k)$
- d)** Find the transfer function $H(z) = X(z)/U(z)$. Does this come from the ZIR or the ZSR?
- e)** Determine $x(0)$, $x(1)$, $x(2)$, $x(3)$, and $x(4)$ from your answer to **c**. Compare this answer with the known values of $x(0)$ and $x(1)$. Using the difference equation compute $x(3)$ and $x(4)$ and compare these values to those in your solution.
- 6)** (From Ogata) Find the *step response* of the following difference equation. Assume $x(0) = 1$ and $x(1) = 2$

$$x(k+2) - x(k+1) + 0.25x(k) = f(k+2)$$

Answer: $x(k) = [4 - (3+k)(0.5)^k]u(k)$

Preparation for Lab 1

7) Consider the following one degree of freedom system we will be utilizing this term:

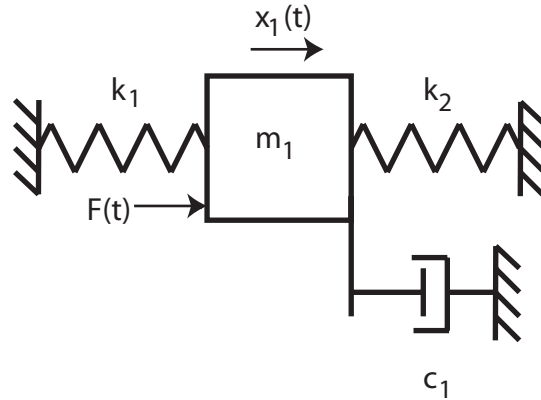

a) Draw a freebody diagram of the forces on the mass.

b) Show that the equations of motion can be written:

$$m_1 \ddot{x}_1(t) + c_1 \dot{x}_1(t) + (k_1 + k_2)x_1(t) = F(t)$$

or

$$\frac{1}{\omega_n^2} \ddot{x}_1(t) + \frac{2\zeta}{\omega_n} \dot{x}_1(t) + x_1(t) = KF(t)$$

c) What are the damping ratio ζ , the natural frequency ω_n , and the static gain K in terms of m_1 , k_1 , k_2 , and c_1 ?

d) Show that the transfer function for the *plant* is given by

$$G_p(s) = \frac{X_1(s)}{F(s)} = \frac{K}{\frac{1}{\omega_n^2} s^2 + \frac{2\zeta}{\omega_n} s + 1}$$

8) One of the methods we will be using to identify ζ and ω_n is the *log-decrement* method, which we will review/derive in this problem. If our system is at rest and we provide the mass with an initial displacement away from equilibrium, the response due to this displacement can be written

$$x_1(t) = Ae^{-\zeta\omega_n t} \cos(\omega_d t + \theta)$$

where

$x_1(t)$ = displacement of the mass as a function of time

ζ = damping ratio

ω_n = natural frequency

ω_d = damped frequency = $\omega_n \sqrt{1 - \zeta^2}$

After the mass is released, the mass will oscillate back and forth with period given by $T_d = \frac{2\pi}{\omega_d}$, so if we measure the period of the oscillation (T_d) we can estimate ω_d .

Let's assume t_0 is the time of one peak of the cosine. Since the cosine is periodic, subsequent peaks will occur at times given by $t_n = t_0 + nT_d$, where n is an integer.

a) Show that

$$\frac{x_1(t_0)}{x_1(t_n)} = e^{\zeta\omega_n T_d n}$$

b) If we define the log decrement as

$$\delta = \ln \left[\frac{x_1(t_0)}{x_1(t_n)} \right]$$

show that we can compute the damping ratio as

$$\zeta = \frac{\delta}{\sqrt{4n^2\pi^2 + \delta^2}}$$

c) Given the initial condition response shown in the Figures 3 and 4 on the next page, estimate the damping ratio and natural frequency using the log-decrement method. (You should get answers that include the numbers 15, 0.2, 0.1 and 15, approximately.)

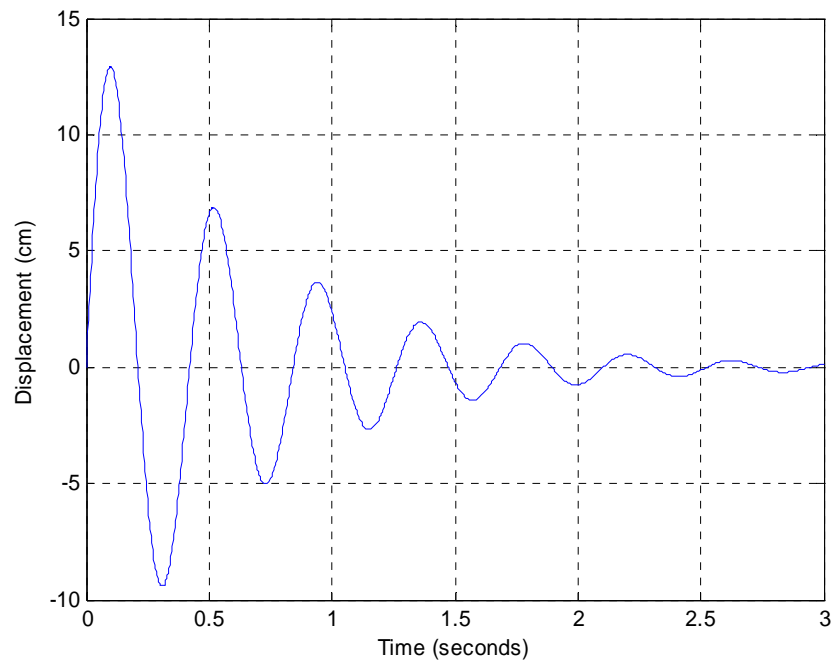

Figure 3. Initial condition response for second order system A.

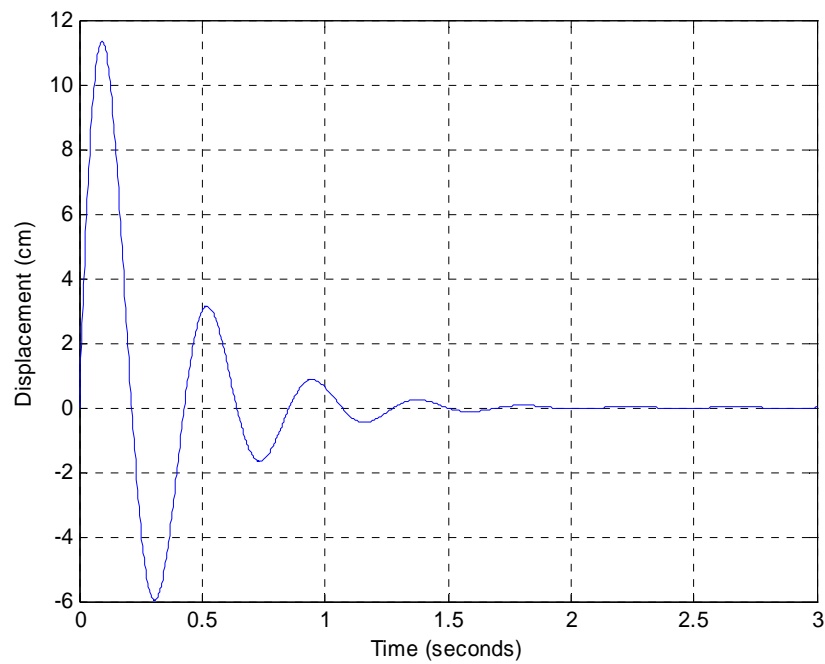

Figure 4. Initial condition response for second order system B.

As you undoubtedly recall, if we have a *stable* system with transfer function $H(s)$, and the input to the system is $u(t) = A \cos(\omega t + \theta)$, then the steady state output is given by

$$y(t) = |H(j\omega)| A \cos(\omega t + \theta + \angle H(j\omega))$$

This is really nothing more than a phasor relationship

$$Y = [|H(j\omega)| \angle H(j\omega)] [|U(j\omega)| \angle U(j\omega)]$$

or

$$\begin{aligned} |Y| &= |H(j\omega)| |U(j\omega)| \\ \angle Y &= \angle H(j\omega) + \angle U(j\omega) \end{aligned}$$

9) Assume

$$H(s) = \frac{s}{s+2}$$

a) If the input to this system is $u(t) = 3 \cos(2t)$ determine the steady state output.

b) If the input to this system is $u(t) = 5 \sin(5t + 10^\circ)$ determine the steady state output.

(Ans. $2.12 \cos(2t + 45^\circ)$, $4.64 \sin(5t + 31.8^\circ)$)

10) In addition to determining $|H(j\omega)|$ and $\angle H(j\omega)$ analytically, we can read these values from a Bode plot of the transfer function. Of course the magnitude portion of a Bode plot is in dB, and we need the actual amplitude $|H(j\omega)|$. For the system with Bode plot given in Figure 5, determine the steady state output of this system if the input is $u(t) = 5 \sin(3t + 20^\circ)$ and $u(t) = 5 \sin(2t + 20^\circ)$.

(Ans. $5 \sin(3t + 20^\circ)$, $1.7 \sin(2t + 65^\circ)$)

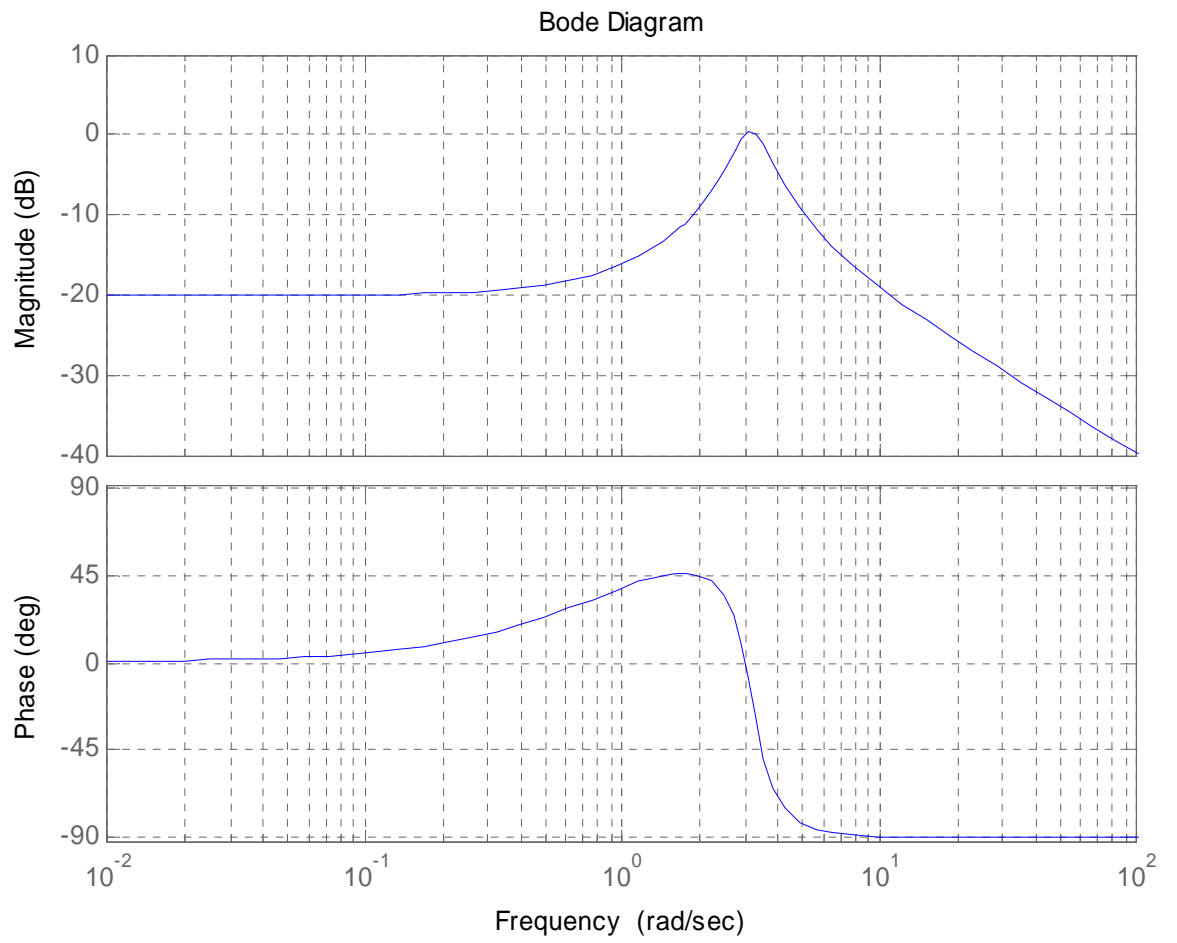

Figure 5: Bode plot of an unknown system.

11) Now we want to use the Bode plot to identify the system. Let's assume the input to an unknown system is a sequence of sinusoids, $u(t) = A \cos(\omega t + \theta)$ at different frequencies and different amplitudes. Once the transients have died out and the system is in steady state we measure the output $y(t)$. We then have the following data:

$$\begin{array}{ll}
 u(t) = 4 \cos(2\pi * 0.25t) & y(t) = 0.089 \cos(2\pi * 0.25t - 0.3^\circ) \\
 u(t) = 4 \cos(2\pi * 0.5t) & y(t) = 0.092 \cos(2\pi * 0.5t - 0.6^\circ) \\
 u(t) = 4 \cos(2\pi * t) & y(t) = 0.104 \cos(2\pi * t - 1.4^\circ) \\
 u(t) = 3 \cos(2\pi * 2t) & y(t) = 0.178 \cos(2\pi * 2t - 6.2^\circ) \\
 u(t) = 3 \cos(2\pi * 2.25t) & y(t) = 0.321 \cos(2\pi * 2.25t - 12.7^\circ) \\
 u(t) = 2 \cos(2\pi * 2.4t) & y(t) = 0.429 \cos(2\pi * 2.4t - 28.1^\circ) \\
 u(t) = 1 \cos(2\pi * 2.5t) & y(t) = 0.424 \cos(2\pi * 2.5t - 75.5^\circ) \\
 u(t) = 1 \cos(2\pi * 2.6t) & y(t) = 0.258 \cos(2\pi * 2.6t - 142.2^\circ) \\
 u(t) = 2 \cos(2\pi * 2.75t) & y(t) = 0.218 \cos(2\pi * 2.75t - 164.1^\circ) \\
 u(t) = 4 \cos(2\pi * 3t) & y(t) = 0.207 \cos(2\pi * 3t - 171.9^\circ) \\
 u(t) = 8 \cos(2\pi * 4t) & y(t) = 0.115 \cos(2\pi * 4t - 176.9^\circ) \\
 u(t) = 10 \cos(2\pi * 5t) & y(t) = 0.075 \cos(2\pi * 5t - 178.0^\circ) \\
 u(t) = 10 \cos(2\pi * 6t) & y(t) = 0.047 \cos(2\pi * 6t - 178.5^\circ) \\
 u(t) = 10 \cos(2\pi * 7t) & y(t) = 0.033 \cos(2\pi * 7t - 178.8^\circ) \\
 u(t) = 10 \cos(2\pi * 8t) & y(t) = 0.024 \cos(2\pi * 8t - 180^\circ)
 \end{array}$$

a) From this data, construct a table with the i^{th} input frequency f_i (in Hz), and the corresponding magnitude of the transfer function at that frequency, $|H_i| = |H(j2\pi f_i)|$. Note that the amplitude of the input is changing. We could also utilize the phase, but we don't need that for the systems we are trying to model.

b) Now we need to try and fit a transfer function to this data, i.e., determine a transfer function that will have the same Bode plot (at least the same magnitude portion). You will need to go through the following steps (you probably want to put this in an m-file...)

```

%
% I won't tell you how to do this again, so pay attention!
%
% Enter the measured frequency response data
%
w = 2 * pi * [f1 f2 ... fn] % frequencies in radians/sec
H = [|H1| |H2| ... |Hn|] % corresponding amplitudes of the transfer function
%
% generate 1000 points (for a smooth curve) between min(w) and max(w)

```

```

% space them out logarithmically
%
ww = logspace(log10(min(w)),log10(max(w)),1000);
%
% next guess the parameters for a second order system, you will have to change these
% to fit the data
%
omega_n = 20;
zeta = 0.1;
K = 0.05
HH = tf(K,[1/omega_n^2 2*zeta/omega_n 1]);
%
% get the frequency response, this is one of many possible ways
%
[M,P] = bode(HH,ww);
M = M(:);
%
% Now plot them both on the same graph and make it look pretty
%
semilogx(w,20*log10(H),'d',ww,20*log10(M),'-'); grid; legend('Measured','Estimated');
ylabel('dB'); xlabel('Frequency (rad/sec)');
title(['K = ' num2str(K) ', \omega_n = ' num2str(omega_n) ', \zeta = ' num2str(\zeta)']);
%
% Note there are spaces between the single quote (') and the num2str function

```

If you have not screwed up, you should get the following graph:

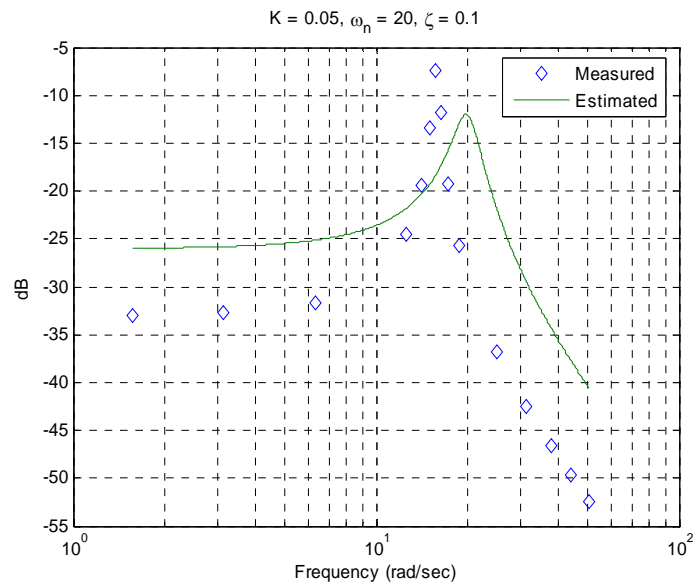

c) Now you need to adjust the parameters of the estimated transfer function to get the best fit. Turn in your final plot with the estimates of the parameters at the top (as in the figure above.)