

ECE-320 Lab 6

Introduction to the dsPIC30F6015

Overview: In this lab we will become familiar with the dsPIC30F6015 and review programming a microcontroller to do some simple things. Most of the initial code will be given to you (see the class website), and you will have to modify the code as you go on. The dsPIC30F6015 has been mounted on a carrier board that allows us to communicate with a terminal (your laptop) via a USB cable. In what follows you will need to make reference to the pin out of the dsPIC30F6015 (shown in Figure 1) and the corresponding pins on the carrier (shown in Figure 2)

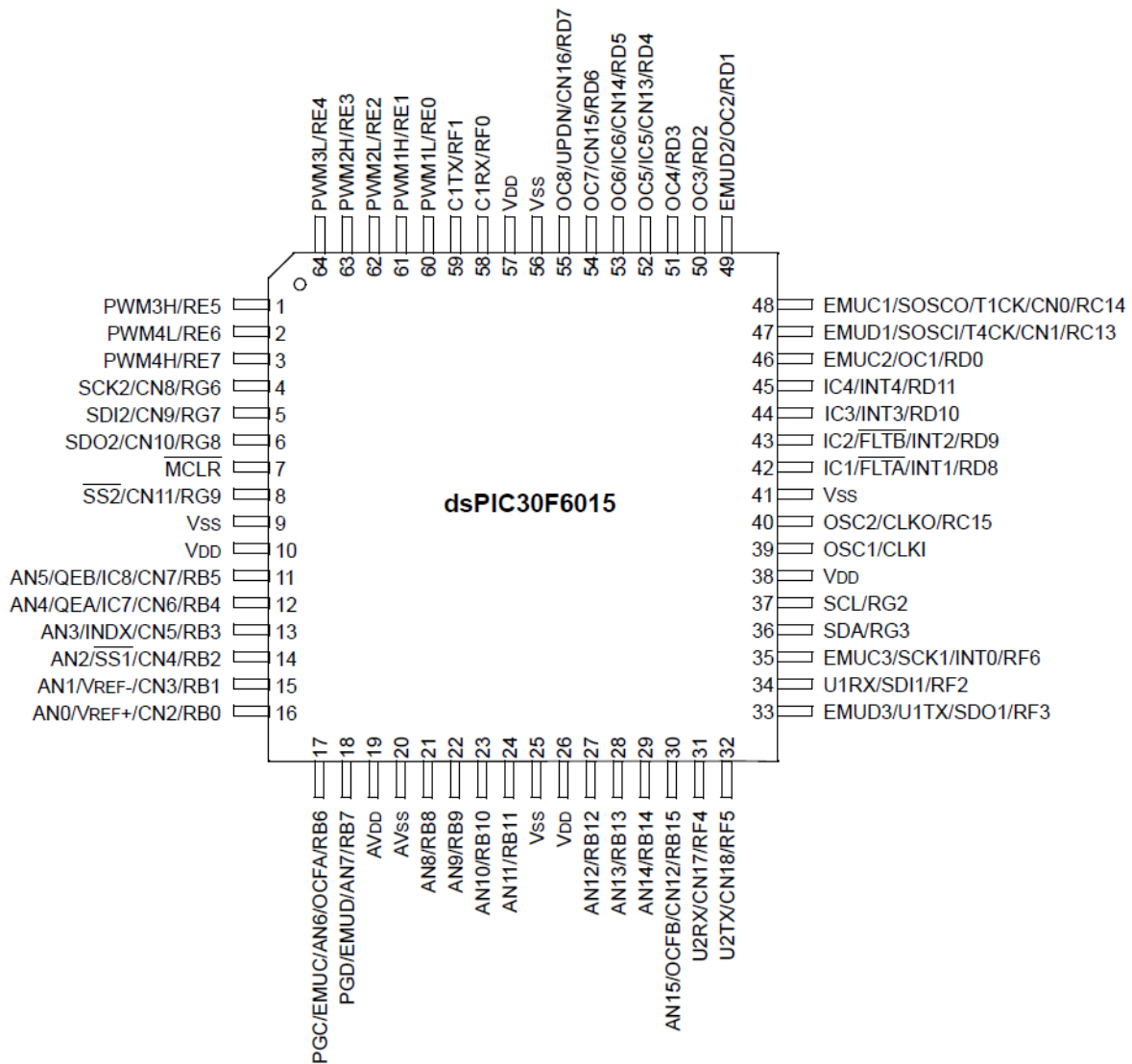

Figure 1. dsPIC30F6015 64-PIN pinout.

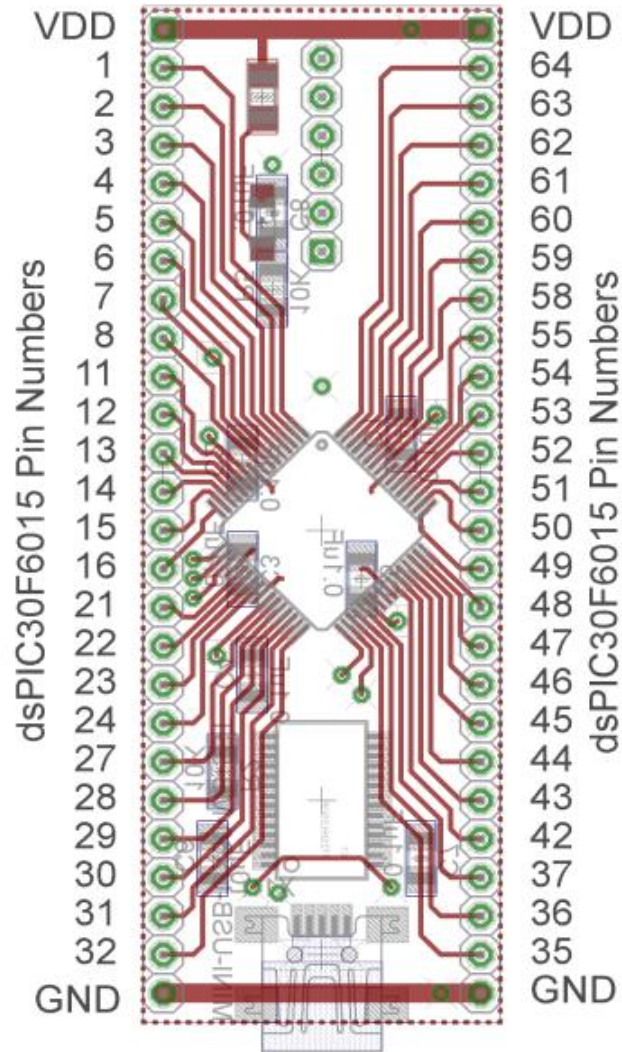

Figure 2. dsPIC30F6015 carrier. Note that the pin numbers are not consecutive.

Part A (Copying the initial files)

Set up a new folder for this lab, and copy the files for this lab from the class website to this folder.

Part B (Downloading and installing MPLAB)

You will need to go to the website

<https://www.microchip.com/pagehandler/en-us/family/mplabx/>

and download the newest version of MPLAB X. If you have an older of MPLAB it will probably work . It is probably easiest to download a zipped version and the unzip it. Do not intall any C compilers yet.

Part C (Downloading and installing MPLAB XC16 compiler)

You will need to go to the website

<https://www.microchip.com/pagehandler/en-us/family/mplabx/>

and download the MPLAB XC16 compiler for the dsPIC. We want to use the free version of the compiler.

Part D (Setting up Communications with Secure CRT)

In this step we will make sure all of our systems are working before we go on.

Connect the PICkit3 to the carrier board and your computer (the white arrow goes near the white spot on the carrier board.)

Connect the separate communication cable to the carrier board and your computer.

Connect power to the power board and toggle to on switch (the green LED should then be on)

Wait a few minutes (see if your system is trying to find any devices). Then go to **Programs->Control Panel -> Hardware and Sound -> Device Manager**. Expand the **Ports** option as shown below. The following figure shows that the USB is connected to my COM5 port. You will need this information shortly.

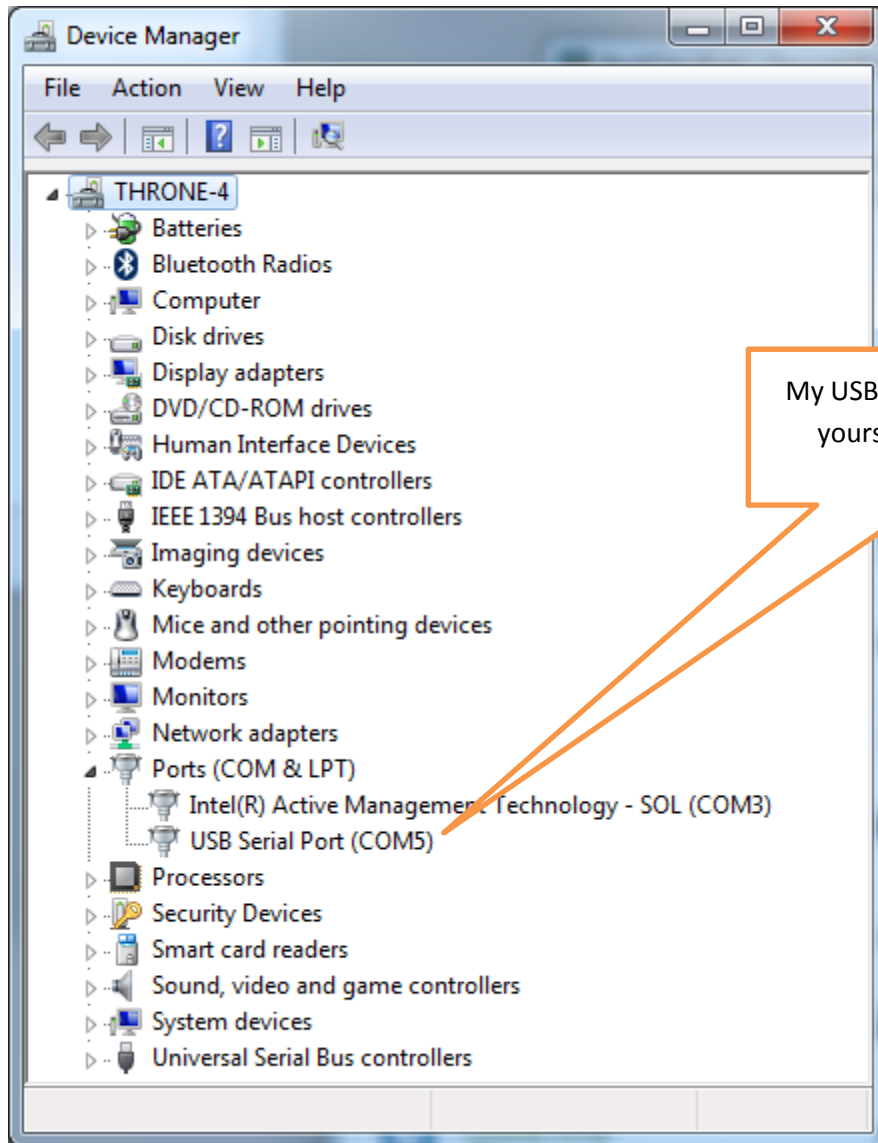

We are going to want to be able to record and plot data, so we will be writing to the screen. In order to do this we will use Secure CRT because it is installed on your computer by default.

Go to **Programs**→**All Programs**→**SecureCRT**→**SecureCRT6.7** (it's ok if you don't have 6.7). You should get a screen like this (although the list of Sessions will probably be shorter for you):

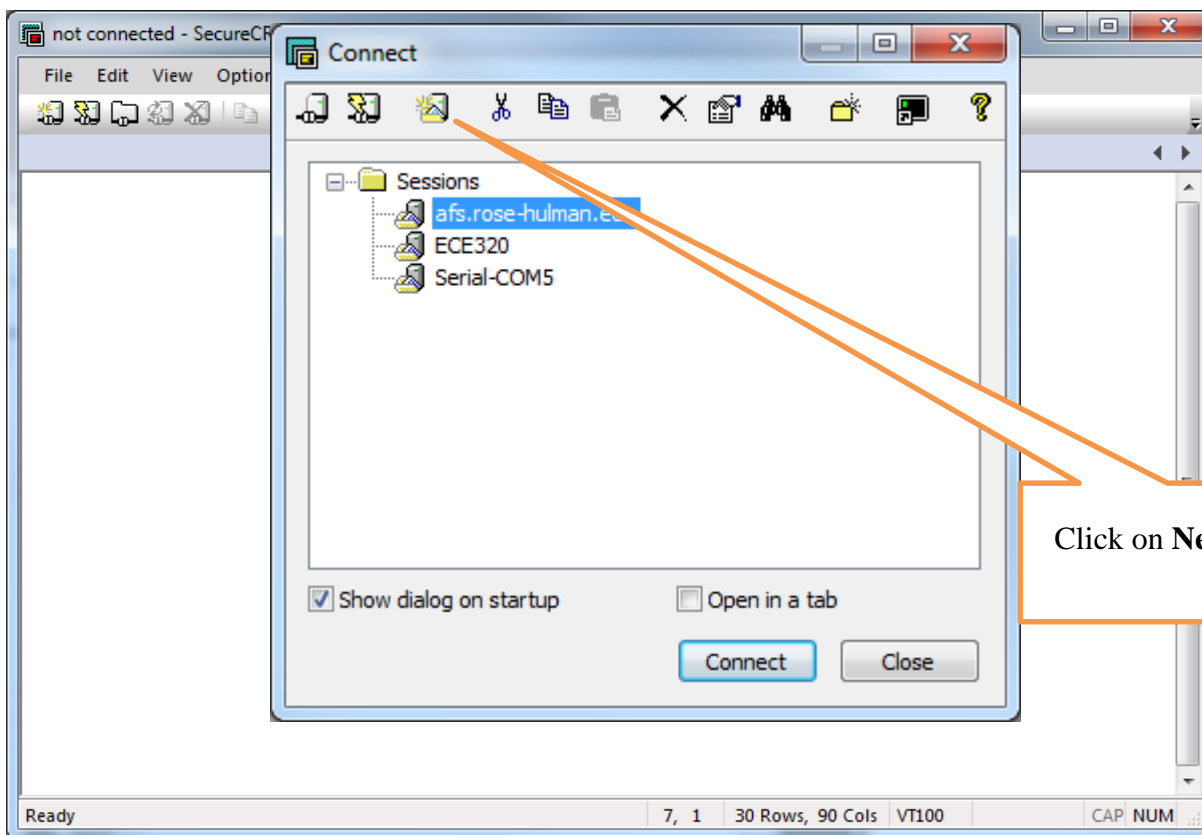

You should then get a screen that looks like this

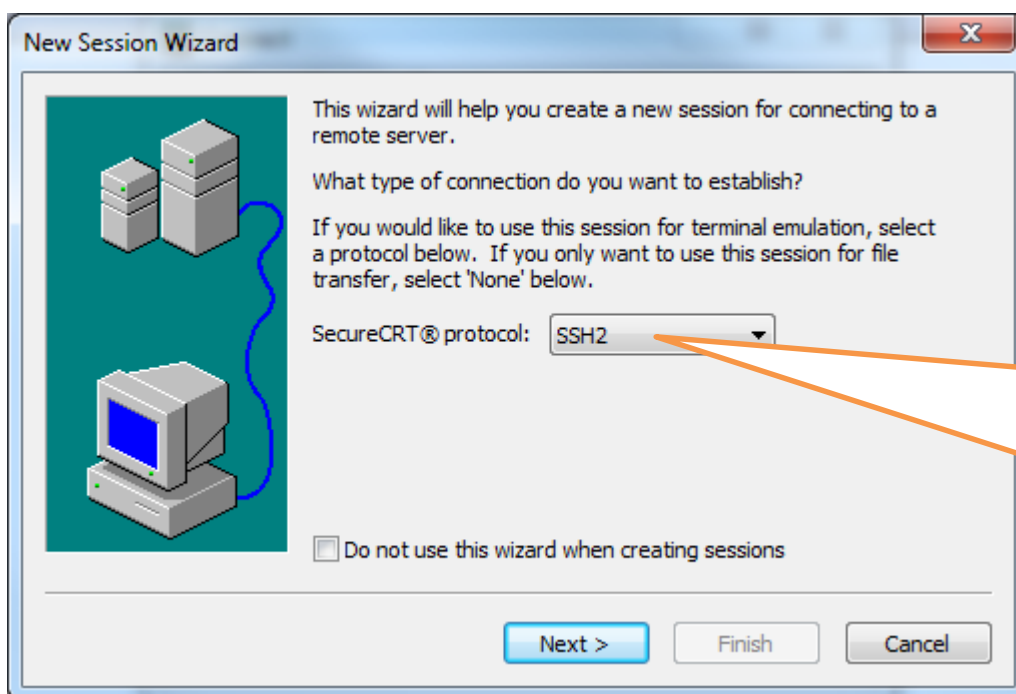

You will next get the following screen. You should already know which port to use (it may not be COM5 on your computer). Select a Baud rate of 115200 and be sure everything is filled in as below. The click on **Next**.

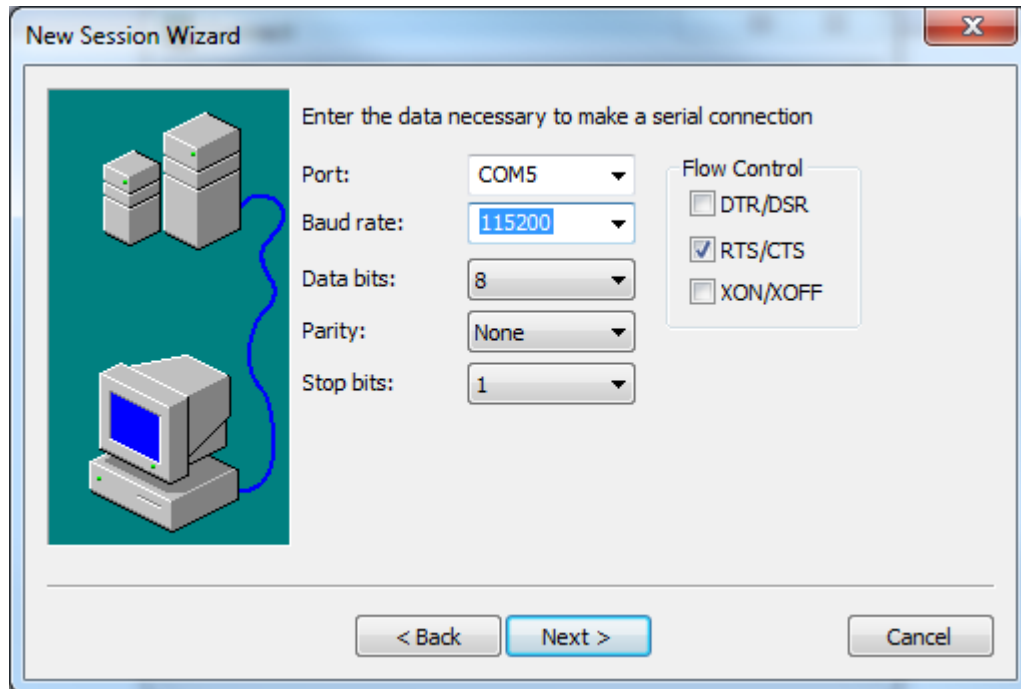

Finally, you need to create a session name so you do not have to go through these steps again. My choice in names was pretty intuitive. Once you have named your session select **Finish**.

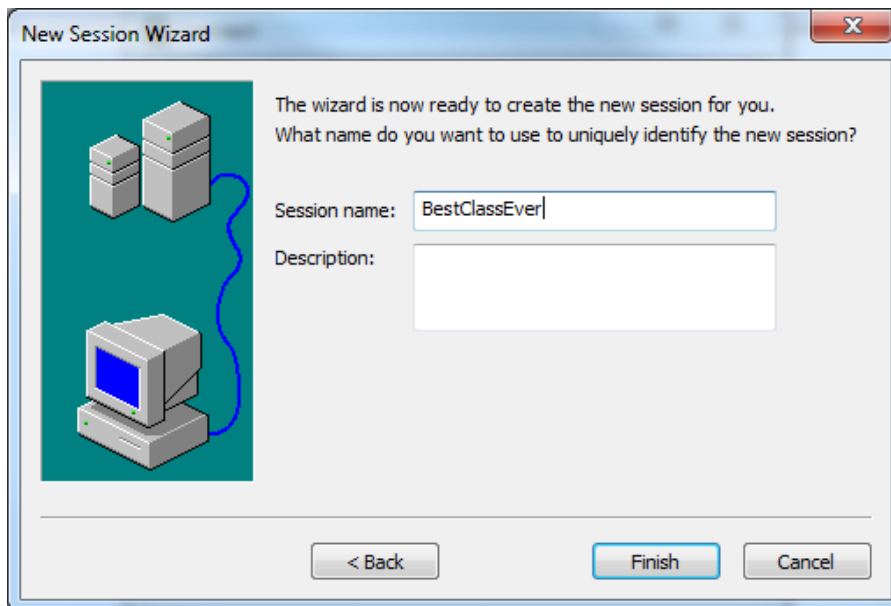

Finally, you may get a screen like that below, and if you do then you need to select **Connect**.

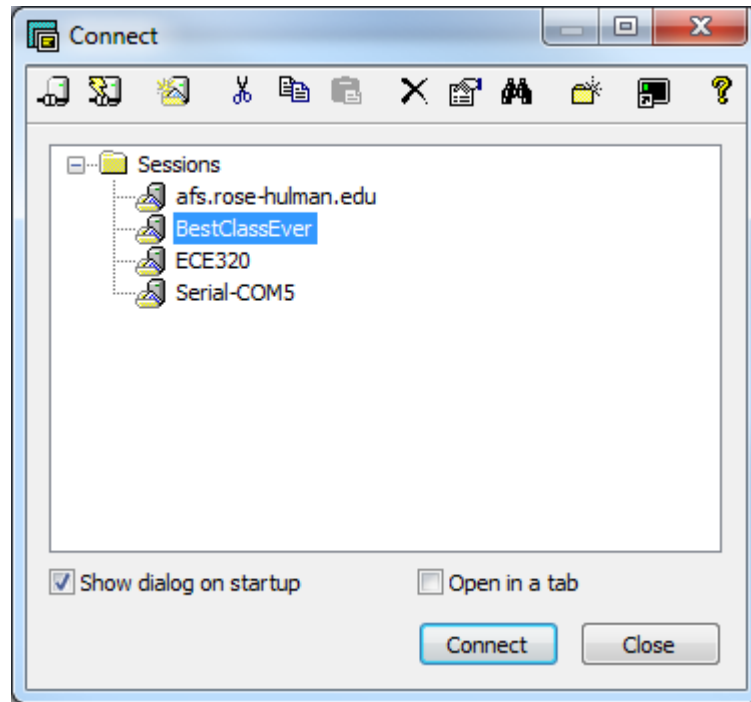

Now you should have a terminal like that shown below

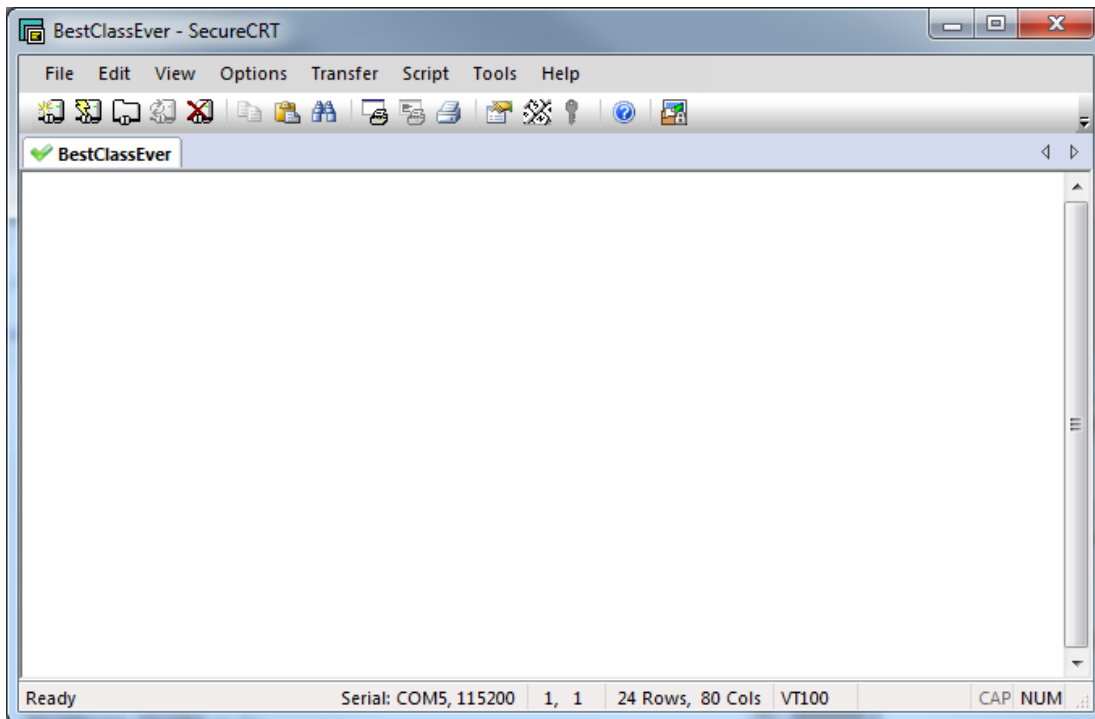

From this screen, the option we will use most is **File-> Log Session**. This will allow us to write data collected to a file to be processed later.

Part E (Putting it all together)

Now we are ready to start. Note that at some point in the following process you may need to let the system download firmware. Be sure you have selected the correct device (or it will do this twice).

Start **MPLAB X IDE (not IPE)**

Select **File**, then **New Project** (the screen should default to **Microchip Embedded** and **Standalone Project**)

Click on **Next**

In the *Select Device* section, select the following:

Family: **16-bit DSCs (dsPIC30)**

Device: **dsPIC30F6015**

Click on **Next**

In the *Select Tool* section, select **PICkit3**

Click on **Next**

In the *Select Compiler* section, select **XC16**

Click on **Next**

In the *Select Project Name and Folder* section, choose a name and project location.

Click on **Finish**

Make sure the file lab6.c is in the Project folder. Right click on **Source Files**, then on **Add Existing Item**, then select lab6.c

Double click on lab6.c and the code will open in a new window.

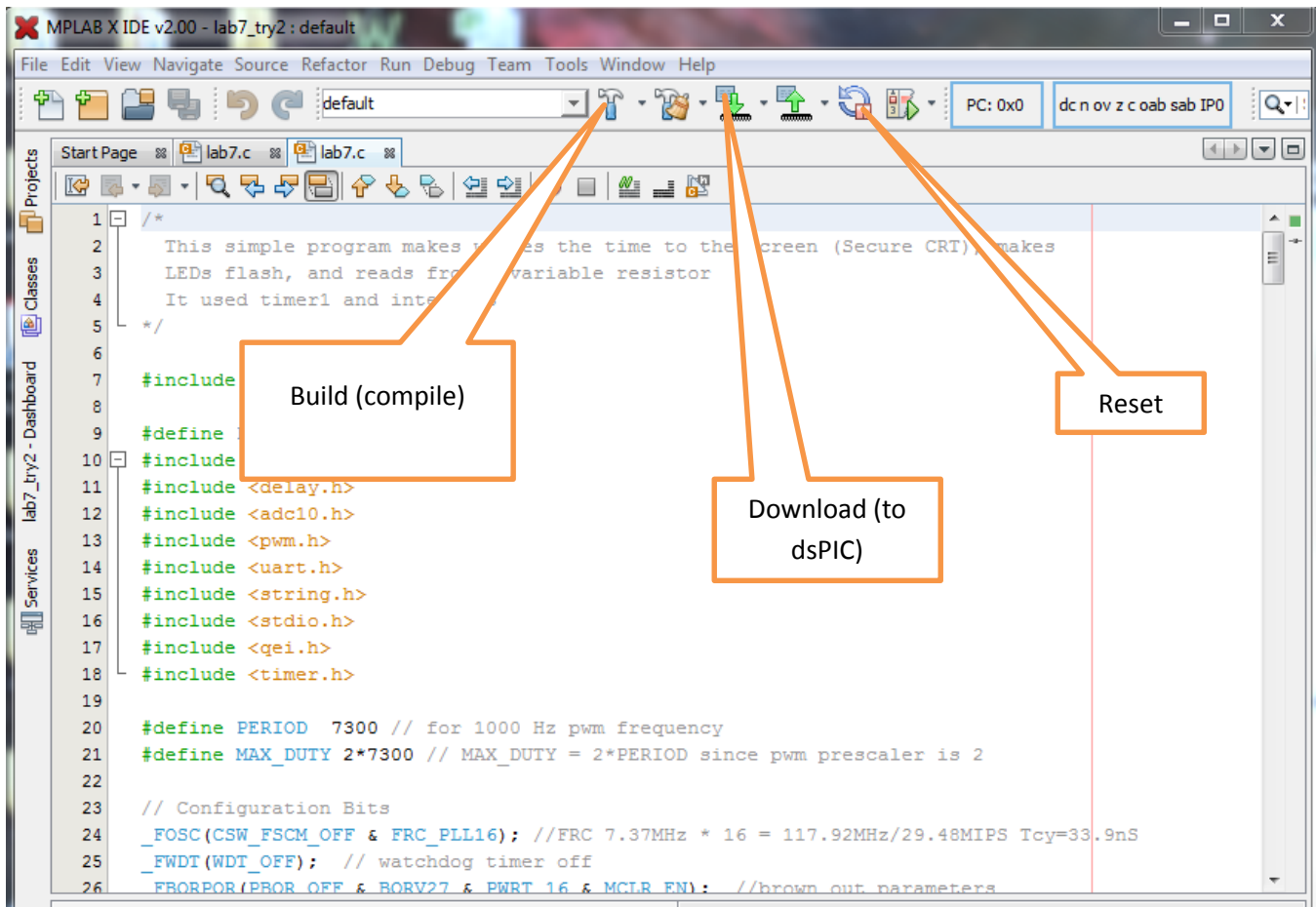

You should **build (compile)** the existing program, **download** it to the dsPIC, and **run** it. You should see a sequence of numbers on your screen (the secure CRT screen). These correspond to sample times.

If you see the following message

You are trying to change protected boot and secure memory. In order to do this you must select the "Boot, Secure and General Segments" option on the debug tool Secure Segment properties page.

Failed to program device

Then

- Right Click on the **Project Name** and select **Properties**
- Under **Categories** in the left panel, click on **PICKit3**
- Under **Option categories** at the top, select **Secure Segment**
- On the right select **Boot, Secure, and General Segments**
- Then select ok at the bottom.

Your program should now compile.

Part F (Turning one LED on and off)

In this step we will make one LED turn on and off.

Locate pin 1 (RE5). Connect a resistor and an LED to this pin as shown below:

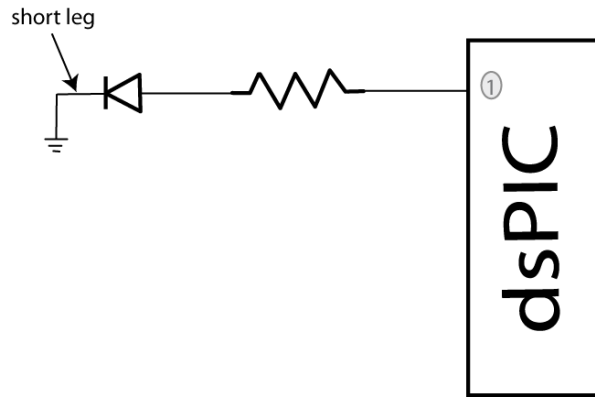

We need to get this ready for output, so in the file **lab6.c**, insert the lines (before the main loop)

```
TRISEbits.TRISE5 = 0;
```

You will see in the main loop we are writing all 1's or all zeros to all of port E every other time interval. Compile your code and run it. Your LED should turn on and off regularly.

Part G (Running Two LEDs)

Connect your other LED to pin2 (RE6). Modify your code so the LED's alternate (one goes on and the other off). Once this has been *verified by your instructor* (see the last page), comment out the code that turns the LEDs on and off in the main code (do not delete it).

Part H (Utilizing PWM to run your LEDs)

We will now utilize the PWM function to drive the LED. Note that RE6 corresponds to PWM4L. (Refer to Figures 1 and 2 to be sure to get the correct pin. Note that not all of the dsPIC pins are on the carrier.) In the routine **pwm_init**, change PWM_PDIS4L to PWM_PEN4L. This allows us to use this pin as a PWM signal. In the main code, uncomment the function call **pwm_init()**;

Uncomment the code:

```
dutycycle = (unsigned int) ((double) AD_value)*scale;
```

```
dutycyclereg = 4;
```

```
SetDCMCPWM( dutycyclereg, dutycycle, updatedisable);
```

This code determines the duty cycle value and writes it to dutycycle register 4.

Just before this segment of code, in the main loop, set `AD_value = 512`. Note that the `AD_value` is actually read from an input and we need to set it just before it is used.

Compile and run your code. A single LED should light (constantly).

Modify the values in `AD_value` from 0 to 512 to verify that the brightness of the LEDs changes as the duty cycle changes. Note that at some point the LED stops getting brighter, so don't worry about that.

Part I (Reading in an A/D value)

Now we want to be able to connect a potentiometer so we can have a variable reference. The software is currently set up for A/D input on AN3/RB3. You will need to do the following things:

- 1) Connect the potentiometer as shown below
- 2) Set the appropriate TRIS bits for an input signal
- 3) Comment out the part of the code that sets the `AD_value`;
- 4) Modify the `printf` statement to allow you to also print out the duty cycle value.

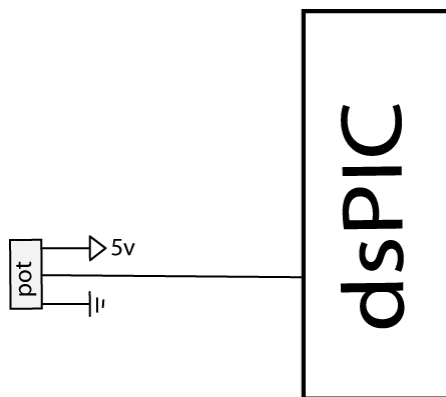

Part J (Changing the duty cycle value by reading from the potentiometer)

Modify your code so the value of the duty cycle in the PWM routine is set by reading in a value from the potentiometer. As you turn the potentiometer the LED should change intensity. The value of the duty cycle should be written to the SecureCRT screen, as well as the current time.

Have this verified by your instructor (see the last page).

Instructor Verification

Names _____

Part G (2 alternating LEDs)

Part J (Pot controls LED and dutycycle written to Secure CRT)
