

ECE-320 Linear Control Systems

Spring 2013, Exam 2

No calculators or computers allowed.

Problem 1 _____/14

Problem 2 _____/15

Problem 3 _____/20

Problem 4 _____/15

Problem 5 _____/15

Problems 6-12 _____/21

Total _____/100

Name _____ Mailbox _____

1) (14 Points) Consider a system with closed loop transfer function $G_o(s) = \frac{k_p}{s + \alpha + k_p}$. The *nominal* values for the parameters are $k_p = 1$ and $\alpha = 2$.

- a) Determine an expression for the sensitivity of the closed loop system to variations in k_p . Your final answer should be written as numbers and the complex variable s .
- b) Determine an expression for the sensitivity of the closed loop system to variations in α . Your final answer should be written as numbers and the complex variable s .
- c) Determine expressions for the *magnitude* of the sensitivity functions in terms of frequency, ω
- d) As $\omega \rightarrow \infty$ the system is more sensitive to which of the two parameters?

2) (15 Points) For the following circuit, the state variables are the current through the inductor and the voltage across the capacitor. Determine a state variable model for this system. Specifically, you need to identify the A, B, C, and D matrices/vectors/scalars. You surely recall the useful relationships

$$v(t) = L \frac{di(t)}{dt}, i(t) = C \frac{dv(t)}{dt}$$

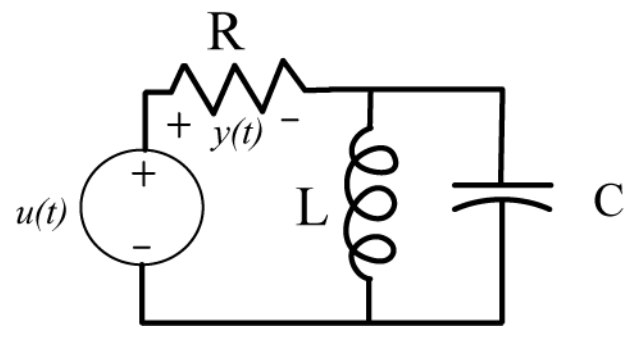

Name _____ Mailbox _____

3) (20 Points) For the state variable model

$$\dot{q} = \begin{bmatrix} 1 & 0 \\ 2 & 1 \end{bmatrix} q + \begin{bmatrix} 1 \\ 1 \end{bmatrix} u$$
$$y = [0 \quad 1]q + [0]u$$

Determine the closed loop transfer function with state variable feedback, $u(t) = G_{pf}r(t) - Kq(t)$

Name _____ Mailbox _____

4) (15 points) For impulse response $h(n) = \left(\frac{1}{2}\right)^n u(n-1)$ and input $x(n) = \left(\frac{1}{4}\right)^{n-2} u(n-1)$, determine

the system output by evaluating the convolution sum $y(n) = \sum_{k=-\infty}^{\infty} h(n-k)x(k)$

Note: you do not have to simplify your answer, but you must remove all sums and include a unit step function of some sort.

5) (15 points) For the following problem, assume the closed loop system below and assume

$$G_p(s) = \frac{3}{(s+2+j)(s+2-j)}$$

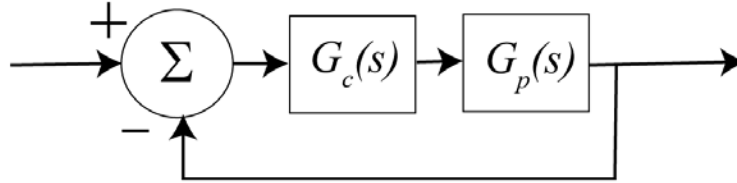

a) Assume we are using an integral controller, so $G_c(s) = \frac{k_i}{s}$. Sketch the root locus, including the direction travelled as the gain increases and the angle of the asymptotes and centroid of the asymptotes, if necessary, and answer the following questions.

i) Is the system always stable?

ii) Determine the position error constant K_p and the steady state error for a unit step in terms of k_i

iii) Determine the velocity error constant K_v and the steady state error for a unit ramp in terms of k_i

Name _____ Mailbox _____

b) Assume we are using a proportional+derivative controller, so $G_c(s) = k(s + z)$. Sketch the root locus assuming $z = 5$, including the direction travelled as the gain increases and the angle of the asymptotes and centroid of the asymptotes, if necessary, and answer the following questions.

i) Is the system always stable?

ii) As $k \rightarrow \infty$, what do you expect the settling time to be?

iii) Determine the position error constant K_p and the steady state error for a unit step in terms of k and z

iv) Determine the velocity error constant K_v and the steady state error for a unit ramp in terms of k and z

Name _____ Mailbox _____

6) Is the following system **controllable**? $G(s) = \frac{G_{pf}}{(s - k_1)(s + k_2)}$

a) Yes b) No c) impossible to determine

7) Is the following system **controllable**? $G(s) = \frac{8G_{pf}}{s^2 + 12s + (k_1 + k_2 + 20)}$

a) Yes b) No c) impossible to determine

8) Is the following system **controllable**? $G(s) = \frac{G_{pf}}{s^2 + (k_2 + k_1 - 1)s + (k_2 + k_1 - 1)}$

a) Yes b) No c) impossible to determine

9) Consider a plant that is unstable but is a controllable system. Is it possible to use state variable feedback to make this system stable?

a) Yes b) No

10) Is it possible for a system with state variable feedback to change the zeros of the plant (other than by pole-zero cancellation) ?

a) Yes b) No

11) Is it possible for a system with state variable feedback to introduce zeros into the closed loop system?

a) Yes b) No

12) If a plant has n poles, then a system with state variable feedback with no pole-zero cancellations will have

a) more than n poles b) less than n poles c) n poles d) it is not possible to tell

Name _____

Mailbox _____