

**ECE-320 Quiz #4**

For problems 1-3 , consider a closed loop system with transfer function

$$G_0(s) = \frac{s+a}{s^2+bs+k}$$

1) The sensitivity to variations in  $k$ ,  $S_k^{G_0}(s)$ , is

- a)  $\frac{k}{s^2+bs+k}$  b)  $\frac{-k}{s^2+bs+k}$  c) 1 d)  $\frac{k}{s+a} - \frac{k}{s^2+bs+k}$  e) none of these

2) The sensitivity to variations in  $b$ ,  $S_b^{G_0}(s)$ , is

- a)  $\frac{-b}{s^2+bs+k}$  b)  $\frac{-bs}{s^2+bs+k}$  c) 1 d)  $\frac{b}{s+a} - \frac{bs}{s^2+bs+k}$  e) none of these

3) The sensitivity to variations in  $a$ ,  $S_a^{G_0}(s)$ , is

- a)  $\frac{a}{s^2+bs+k}$  b)  $\frac{-a}{s^2+bs+k}$  c) 1 d)  $\frac{a}{s+a}$  e) none of these

4) Assume we compute the sensitivity of a system with nominal value  $a = 4$  to be

$$S_a^{G_0}(s) = \frac{1}{s+a}$$

For what frequencies will the sensitivity function be less than  $\frac{1}{\sqrt{32}}$ ?

- a)  $\omega < 4$  rad/sec b)  $\omega > 4$  rad/sec c)  $\omega > 16$  rad/sec d)  $\omega < 16$  rad/sec e) none of these

5) Assume we compute the sensitivity of a system with nominal value  $a = 3$

to be

$$S_a^{G_0}(s) = \frac{s+2}{s+1+a}$$

For what frequencies will the sensitivity function be greater than  $\sqrt{\frac{10}{16}}$ ?

- a)  $\omega < 4$  rad/sec b)  $\omega > 4$  rad/sec c)  $\omega > 16$  rad/sec d)  $\omega < 16$  rad/sec e) none of these

Problems 6-9 refer to the following system

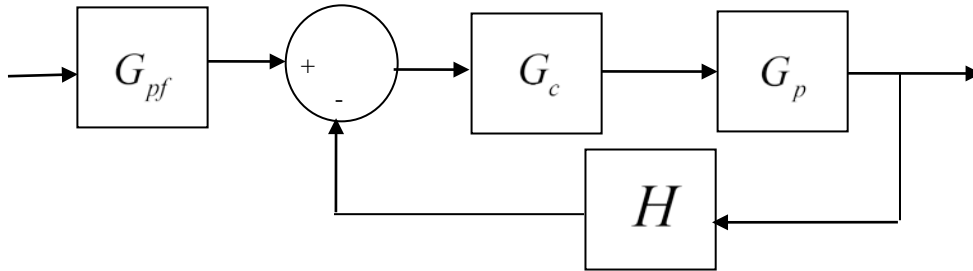

6) To reduce the sensitivity of the closed loop transfer function variations in the plant  $G_p$ , we should

- a) make  $|G_c(j\omega)G_p(j\omega)H(j\omega)|$  large
- b) make  $|G_c(j\omega)G_p(j\omega)H(j\omega)|$  small
- c) make  $G_{pf}$  large
- d) do nothing, we cannot change the sensitivity

7) To reduce the sensitivity of the closed loop transfer function to variations in the prefilter  $G_{pf}$ , we should

- a) make  $|G_c(j\omega)G_p(j\omega)H(j\omega)|$  large
- b) make  $|G_c(j\omega)G_p(j\omega)H(j\omega)|$  small
- c) make  $G_{pf}$  small
- d) do nothing, we cannot change the sensitivity

8) To reduce the sensitivity of the closed loop transfer function to variations in the controller  $G_c$  we should

- a) make  $|G_c(j\omega)G_p(j\omega)H(j\omega)|$  large
- b) make  $|G_c(j\omega)G_p(j\omega)H(j\omega)|$  small
- c) make  $|H(j\omega)|$  large
- d) do nothing, we cannot change the sensitivity

9) To reduce the sensitivity of the closed loop transfer function to variations in the sensor  $H$ , we should

- a) make  $|G_c(j\omega)G_p(j\omega)H(j\omega)|$  large
- b) make  $|G_c(j\omega)G_p(j\omega)H(j\omega)|$  small
- c) make  $G_{pf}$  large
- d) do nothing, we cannot change the sensitivity

10) For the system below

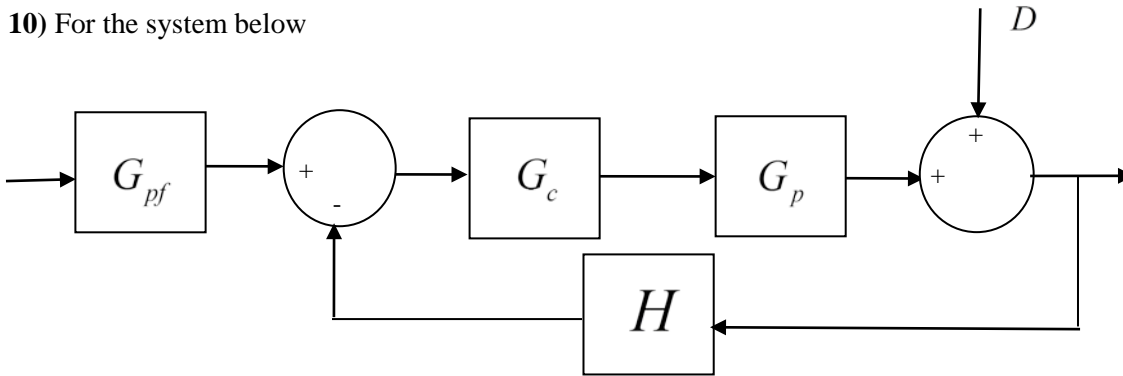

to reduce the effects of the external disturbance  $D$  on the system output, we should

- a) make  $|G_c(j\omega)G_p(j\omega)H(j\omega)|$  large
- b) make  $|G_c(j\omega)G_p(j\omega)H(j\omega)|$  small
- c) make  $G_{pf}$  large
- d) do nothing, we cannot change the sensitivity

11) For the system below

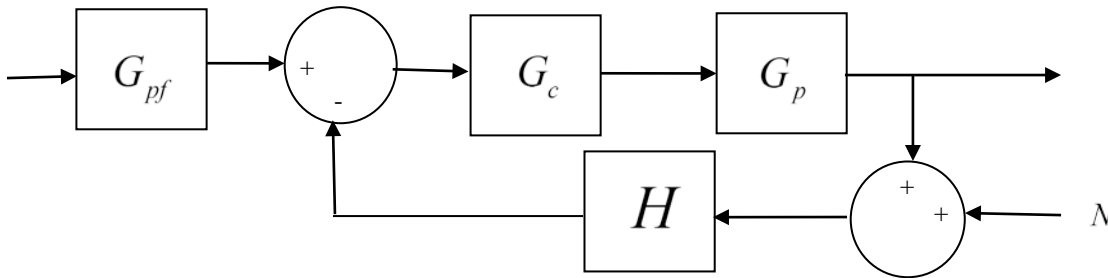

to reduce the effects of sensor noise  $N$  on the closed loop system, we should

- a) make  $|G_c(j\omega)G_p(j\omega)H(j\omega)|$  large
- b) make  $|G_c(j\omega)G_p(j\omega)H(j\omega)|$  small
- c) make  $|H(j\omega)|$  large
- d) do nothing, we cannot change the sensitivity