

## **System Step and Impulse Response**

Lab 04

Bruce A. Ferguson

In this laboratory, you will investigate basic system behavior by determining the step and impulse response of a simple RC circuit. You will also determine the time constant of the circuit and determine its rise time, two common figures of merit (FOMs) for circuit building blocks.

### **Objectives**

1. Design an experiment by specifying a test setup, choosing circuit component values, and specifying test waveform details to investigate the step and impulse response.
2. Measure the step response of the circuit and determine the rise time, validating your theoretical calculations.
3. Measure the impulse response of the circuit and determine the time constant, validating your theoretical calculations.

### **Prelab**

Find and bring a circuit board to the lab so you can build the RC circuit.

### **Background**

As we introduce the study of systems, it will be good to keep the discussion well grounded in the circuit theory you have spent so much of your energy learning. An important problem in modern high speed digital and wideband analog systems is the response limitations of basic circuit elements in high speed integrated circuits. As simple as it may seem, the lowly RC lowpass filter accurately models many of the systems for which speed problems are so severe.

There is a basic need to be able to characterize a circuit independent of its circuit design and layout in order to predict its behavior. Consider the now-overly-familiar RC lowpass filter shown in Figure 1. We could describe this system by showing its circuit schematic or by calculating its impulse response or transfer function. But in many cases only FOMs are important to determine the adequacy of the system.

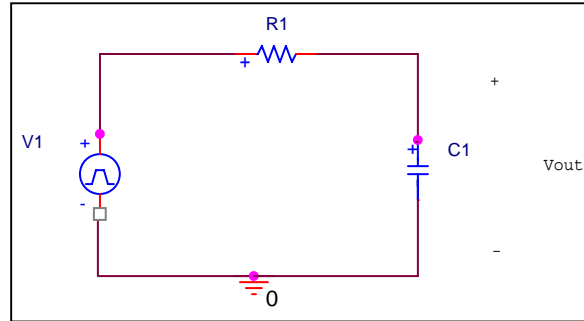

Figure 1. Simple RC lowpass filter circuit.

The first FOM is the system time constant. Many simple systems display a characteristic exponential decay (or rise) in their response. Since the form of the response is known, the only data important to characterize a specific system is the numerical value of its time constant.

The second FOM, the risetime, characterizes the response of the system to a positive step change in input. The response of the circuit of Figure 1 to an applied unit step input is shown in Figure 2. The rise time most typically used as a FOM for a first order system is the “10-90% risetime”, which is simply the amount of time necessary for the output to rise from 10% to 90% of its final value. This measurement is shown in Figure 2 as the time difference between the times  $t_{10}$  and  $t_{90}$ . These values can easily be determined given the step response of the system.

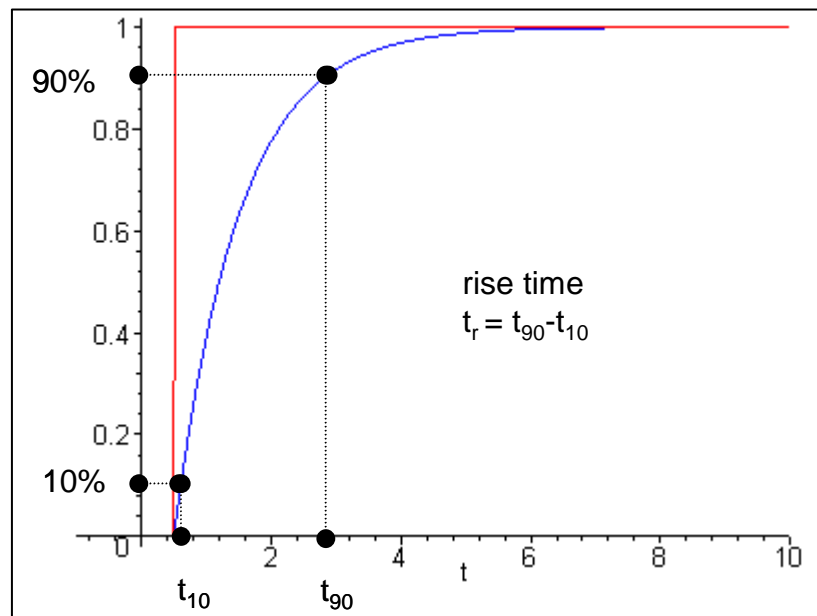

Figure 2. Step response of the RC lowpass filter circuit of Figure 1, showing the definition of the 10-90% risetime.

The 10-90% risetime FOM is especially important in digital systems, as excessive “slurring” of the crisp edges of the digital waveform leads to rapid degradation in system performance.

The risetime is a slightly deceiving measurement for certain circuits, since the rise time depends in part on the magnitude of the step change in output the circuit must produce. For this reason, a related FOM, the slew rate, is required to describe the maximum voltage change per unit time which the circuit can produce.

Figure 3 shows a typical impulse response for the RC filter of Figure 1. The characteristic exponential decay is just as we remember from class. The time constant of the circuit is defined as the time it takes for the response to decay to  $1/e$  (37%) times its initial value. Since the functional form of the response is  $\exp(-t/RC)$ , the time constant of the circuit can easily be shown to be simply  $RC$ .

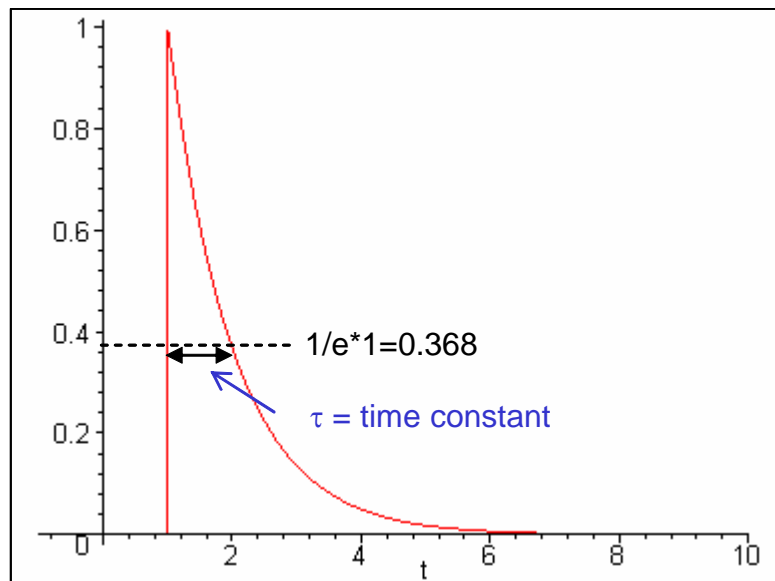

Figure 3. Impulse response of the RC lowpass filter circuit of Figure 1, showing the definition of the circuit time constant.

The time constant FOM allows us to determine the behavior of the circuit in a number of important scenarios, such as digital signal response or the time until steady-state analysis results are valid.

Measuring these two FOMs in the laboratory is actually a relatively simple effort for low bandwidth systems. The requirements are the circuit, or the *system under test* (CUT or SUT), and appropriate step and impulse waveform generation and measurement equipment. However, some thought needs to go into the waveform specification in order to facilitate measurement of the two FOMs.

The basic test setup is shown in Figure 4. The trick is to be able to create a “unit step” and an “impulse” waveform to test the system. Of course, we cannot create either of these two ideal waveforms in our part of the universe. However, we can create reasonable approximations.

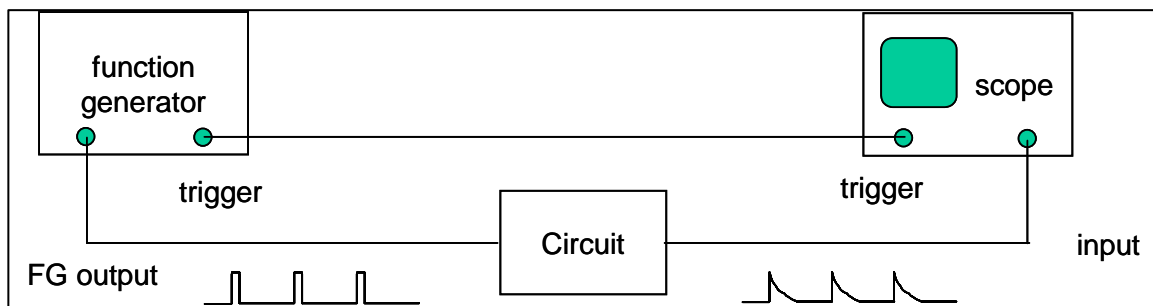

Figure 4. Experimental test setup for measuring the impulse and step response of the SUT.

How can we approximate a unit step impulse? There are three important aspects of the step waveform to consider. First, the waveform must have a fast transition from off to on. Second, the waveform must stay “on” long enough for the system transients to die out. Thus, we could imagine a suitably wide pulse as being a reasonable approximation to a step input. The third aspect has to do with how we create the step change in the waveform.

To simulate the impulse waveform, we could use a suitably abrupt and high amplitude pulse waveform. But what constitutes “suitably abrupt”? Well, if we can produce a pulse whose time width is much less than the time constant of the circuit, with a suitably large amplitude, then the pulse would provide a reasonable approximation of an impulse *for that circuit*. That same pulse might not be short enough in duration to approximate an impulse for a different circuit having a shorter time constant.

Each of the two waveforms discussed above are *single-shot* events, or events that occur only once in time. The oscilloscopes we use are optimized for periodic waveforms, not single-shot events. No worries - we can create a pulse train with our function generators which allow for both control of pulse widths for impulse/step waveform design, as well as repeating these pulses periodically to optimize the viewing of the waveforms on the oscilloscope screen. However, the period of the waveform should be long enough to let all transients die out in the circuit before the next impulse arrives.

## Equipment

- Function Generator
- Oscilloscope
- RC lowpass filter circuit of your design

## Procedure

*Fill out the worksheet at the end of this lab as you are doing the lab.*

### RC Circuit Step Response

1. Set up the laboratory equipment as shown in Figure 4. Be sure to use the higher frequency capability function generator. Construct your RC circuit using the values of R and C you determined in the Prelab exercises. Calculate the *actual* time constant for your circuit using *actual measured* component values.
2. Determine the waveform setting for the function generator shown in Figure 4 for simulating a step input waveform for this circuit.
3. Display the RC system step response on your oscilloscope screen and capture the screen display. *Be sure the system has reached steady state (the output is flat) before you estimated your time constant!* From the waveform, determine the 10-90% rise time for the circuit and indicate it on the plot. From the prelab, the rise time is related to the system time constant through the relationship  $t_r = \tau \ln(9)$ . Compare the waveform and risetime you measured to your theoretical calculations.

Instructor Verification (see last page)
---

### RC Circuit Impulse Response

4. Determine the waveform setting for the function generator shown in Figure 4 for simulating an impulse waveform for this circuit. What is the area of *your* lab impulse?
5. Display the RC system impulse response on your oscilloscope screen and capture the screen display. From the waveforms, determine the time constant for the circuit, and indicate it on the plot.
  - a. Compare the waveform and time constant you measured to your theoretical calculations.
  - b. Compare the amplitude of your output exponential match to what you predicted in the prelab:  $y_{pulse}(T) = \frac{AT}{\tau}$ , where A is the amplitude of the pulse, T is the duration of the pulse, and  $\tau$  is the system time constant.

Instructor Verification (see last page)
---

## System Step and Impulse Response Instructor Verification Sheet

Turn this page in to your Professor

Name \_\_\_\_\_ Date of Lab: \_\_\_\_\_

*Be sure to include the screen captures for the step and impulse responses, and comparisons between the measured time constants and the estimated time constants.*

Measured resistance is \_\_\_\_\_ Measured capacitance is \_\_\_\_\_

The actual time constant  $\tau$  is \_\_\_\_\_

The time constant estimated using the **step response** is \_\_\_\_\_

Compute the percentage error:

Part (3) Display step response and compare with theory.

Verified: \_\_\_\_\_ Date/Time: \_\_\_\_\_

The time constant estimated using the **impulse response** is \_\_\_\_\_

Compute the percentage error:

The predicted amplitude at the trailing edge of the pulse,  $y_{pulse}(T) = \frac{AT}{\tau}$ , is \_\_\_\_\_

The measured amplitude at the trailing edge of the pulse is \_\_\_\_\_

Compute the percentage error:

Part (5) Display impulse response and compare RC time constant measurement with calculation.

Verified: \_\_\_\_\_ Date/Time: \_\_\_\_\_