

# **ECE-205**

## **Exam 3**

### **Spring 2013**

**Calculators and computers are not allowed. You must show your work to receive credit.**

**Problem 1 \_\_\_\_\_/16**

**Problem 2 \_\_\_\_\_/12**

**Problem 3 \_\_\_\_\_/18**

**Problem 4 \_\_\_\_\_/15**

**Problem 5 \_\_\_\_\_/15**

**Problem 6 \_\_\_\_\_/24**

**Total \_\_\_\_\_**

Name \_\_\_\_\_ CM \_\_\_\_\_

1) (16 points) For the following transfer functions, determine **both**

- the impulse response and
- the unit step response

of the system. *Do not forget any necessary unit step functions.*

a)  $H(s) = \frac{e^{-5s}}{s(s+2)}$

b)  $H(s) = \frac{3}{s^2 + 6s + 13}$

**2) (12 points)** Consider the following simple feedback control block diagram. The plant, the thing we want to control, has the transfer function  $G_p(s) = \frac{5}{s+3}$

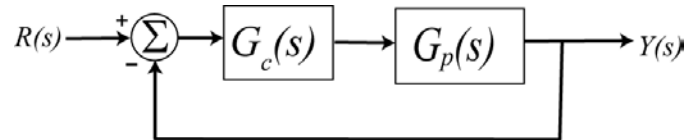

- a) Determine the settling time of the plant alone (assuming there is no feedback)
  
- b) Determine the steady state error for plant alone assuming the input is a unit step (simplify your answer)
  
- c) For a proportional controller,  $G_c(s) = k_p$ , determine the closed loop transfer function  $G_0(s)$
  
- d) Determine the settling time of the closed loop system, in terms of  $k_p$
  
- e) Determine the steady state error of the closed loop system for a unit step, in terms of  $k_p$  (simplify your answer)
  
- f) For an integral controller,  $G_c(s) = \frac{k_i}{s}$ , determine the closed loop transfer function  $G_0(s)$  and the steady state error for a unit step in terms of  $k_i$

3) (18 points) For the following circuit,

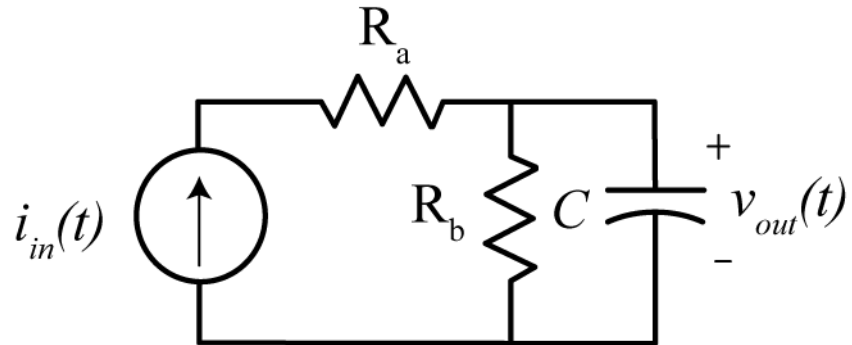

Determine expressions for the following in terms of the parameters given

- a) the zero input response (ZIR)
- b) the zero state response (ZSR)
- c) the transfer function
- d) the impulse response

4) (15 points) For the following block diagram

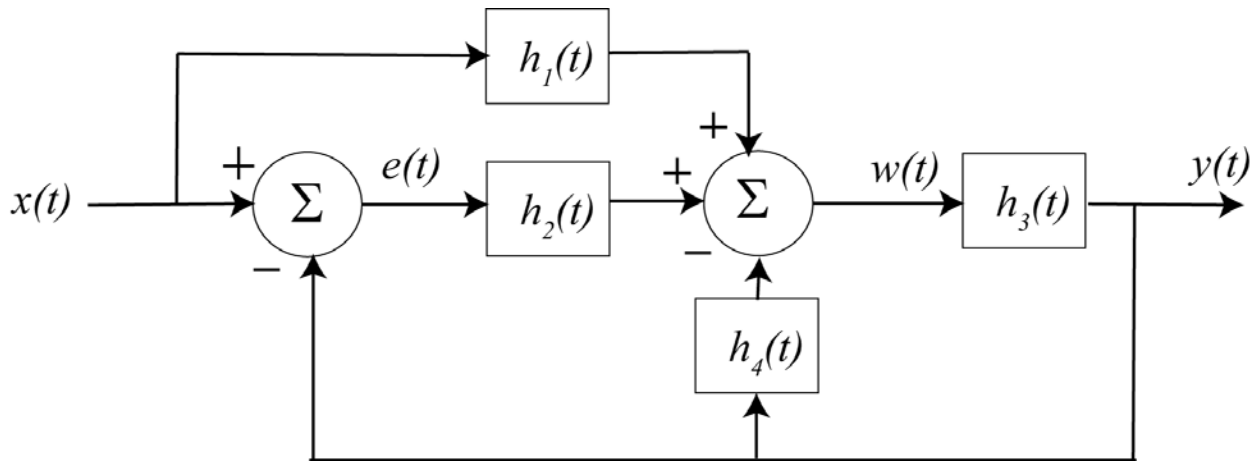

Draw the corresponding signal flow graph, labeling each branch and direction. *Feel free to insert as many branches with a gain of 1 as you think you may need.*

Determine the system transfer function using Mason's gain rule. *You must clearly indicate all of the paths, the loops, the determinant and the cofactors. **You need to simplify your final answer!***

**5) (15 points)** Determine the transfer function for the following circuit in terms of the parameters given. For full credit you must simplify your result as much as possible. Specifically, for full credit your answer must be the ratio of two polynomials. You do not need to multiply the polynomial out, but you cannot have fractions in the numerator or the denominator.

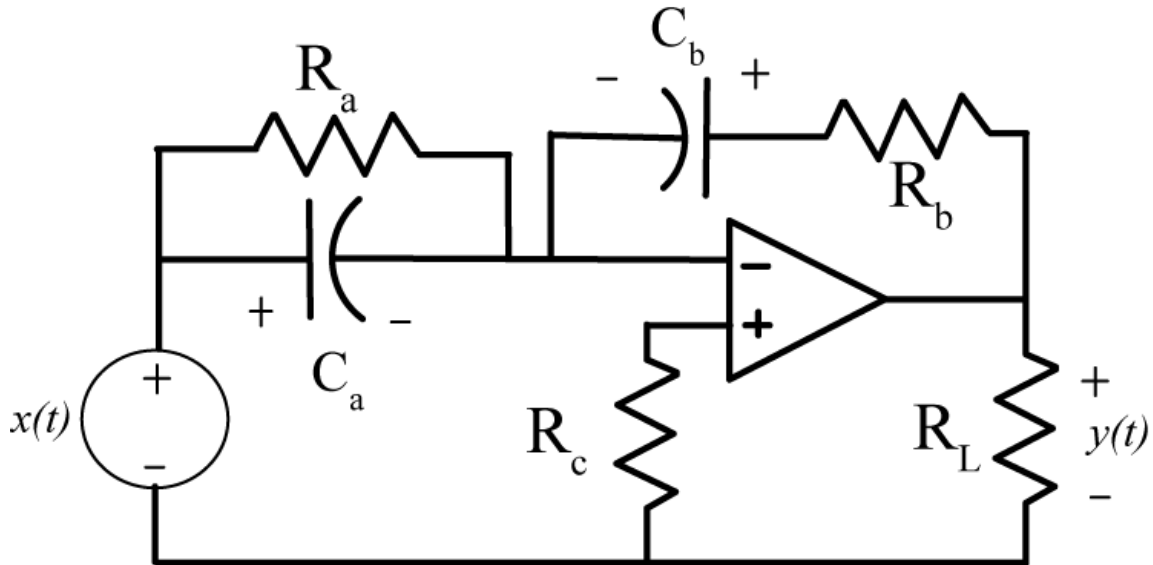

**6) (24 Points)** An LTI system has input, impulse response, and output as shown below. Determine numerical values for the parameters  $a-k$ . Note that parameters  $a-g$  correspond to *times*, and  $h-l$  correspond to *amplitudes*.

Note that the output is not drawn to any particular scale and only represents the general shape of the actual output. Specifically, you should not depend on the graph shown to determine any specific values.

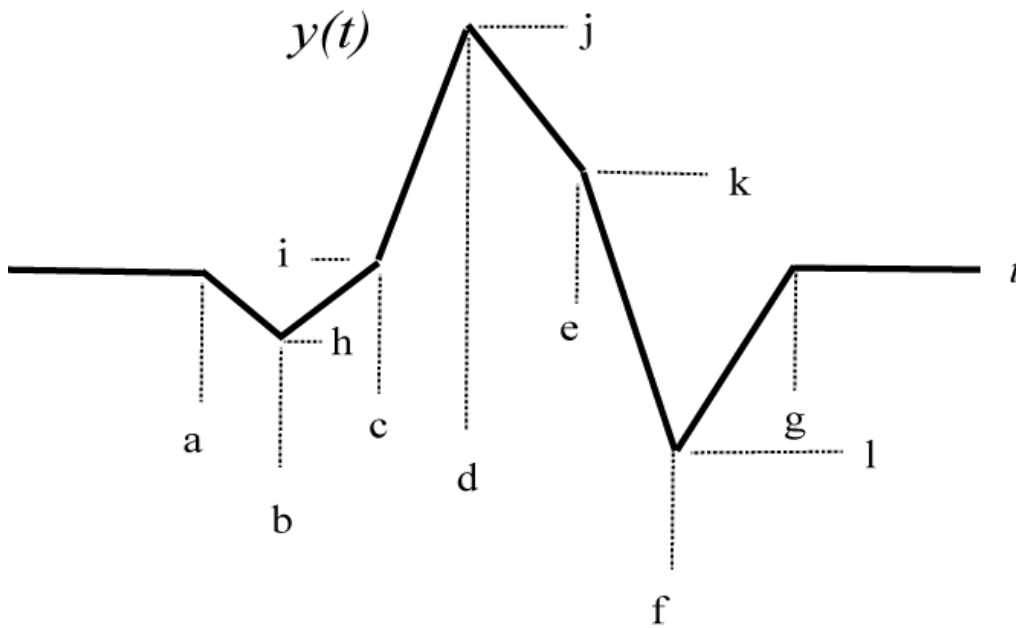
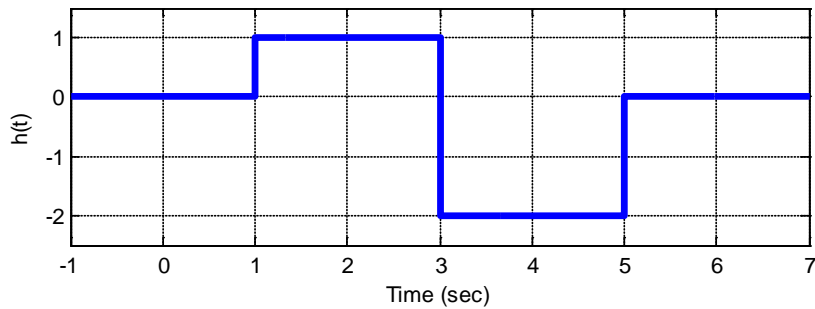
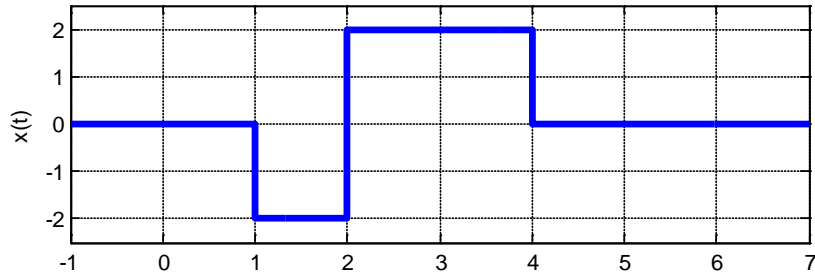

Name \_\_\_\_\_ Mailbox \_\_\_\_\_



Name \_\_\_\_\_ Mailbox \_\_\_\_\_

Name \_\_\_\_\_ Mailbox \_\_\_\_\_