

ECE 130 HW#11, Due Tuesday, April 12

In class we implemented a 4-bit BCD adder block. Use your simulation software to build the circuit that we implemented in class. Reminder: use only 2 4-bit (hex) adders, 2 2-input ANDs, 1 3-input OR, and 4 2:1 MUXs. Test it with the following inputs:

4 + 5

2 + 8

9 + 9

The circuit from class is:

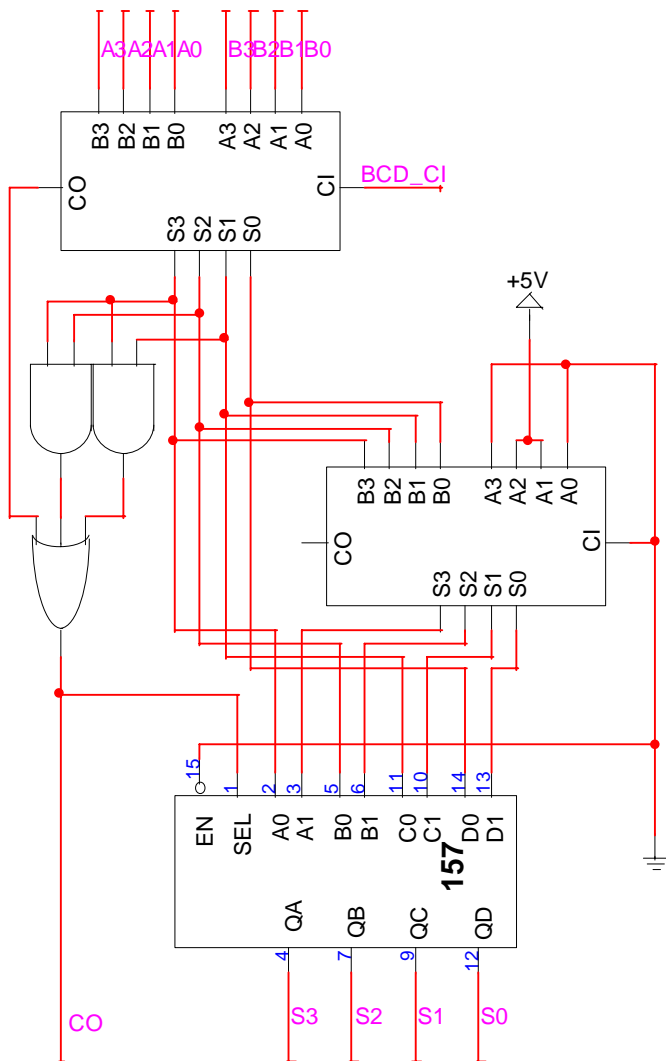

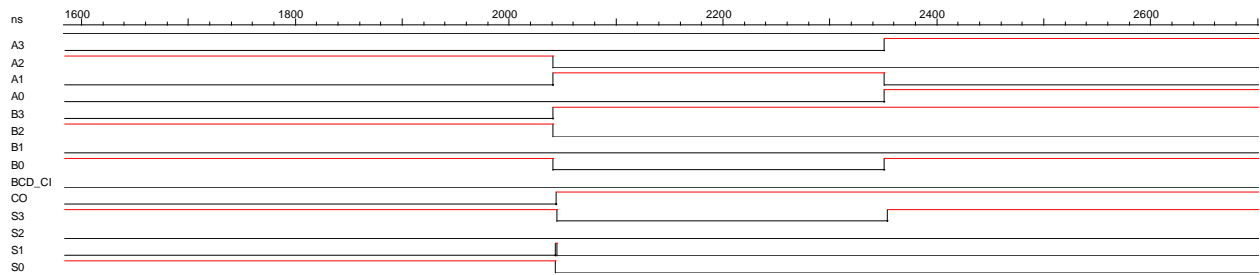

Although the circuit we built in class was a good demonstration of using lots of different components, it can actually be built using many less. Build a second circuit that only uses 2 4-bit (hex) adders, 1 8:1 mux, and a 2-input OR gate. Test your circuit with the same test cases as above.

