

ECE 130 HW#9 Due Tuesday, April 12

1. Implement the canonical expression $f(x,y,z) = \Sigma(1,3,5,6,7)$ using only ONE 74LS138 decoder and as many 2-input NAND gates as you like. Build your circuit using simulation software and verify that it gives the correct output.

Note that the decoder is a minterm generator. For example, the active low output $Y0 = (x'y'z')$.

$$\begin{aligned}
 f(x,y,z) &= \Sigma(1,3,5,6,7) \\
 &= x'y'z + x'yz + xy'z + xyz + xyz \\
 &= ((x'y'z)' * (x'yz)' * (xy'z)' * (xyz)')' \quad (\text{five-input NAND}) \\
 &= (Y1 * Y3 * Y5 * Y6 * Y7)' \\
 &= ((Y1 * Y3)'' * (Y5 * (Y6 * Y7)')'')' \quad (\text{use NANDs as inverters; 7 2-input NANDs})
 \end{aligned}$$

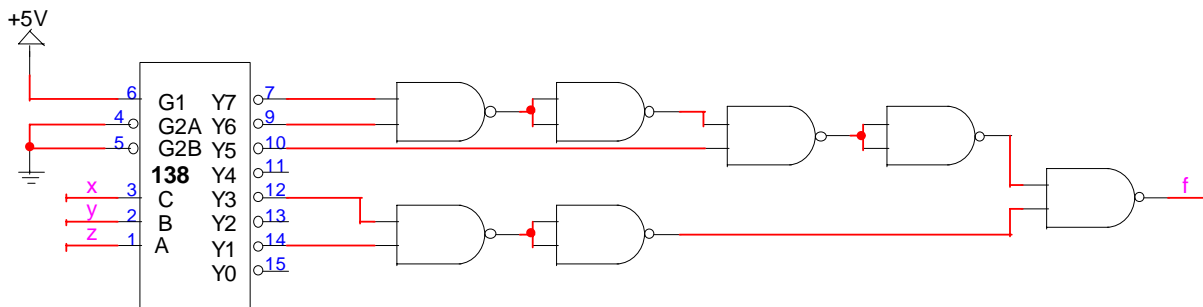

$$\begin{aligned}
 f(x,y,z) &= \prod(0,2,4) \\
 &= (x+y+z) * (x+y'+z) * (x'+y+z) \\
 &= (x'y'z')' * (x'yz')' * (xy'z')' \quad (\text{three-input AND}) \\
 &= Y0 * Y2 * Y4 \\
 &= ((Y0*Y2)'' * Y4)'' \quad (\text{use NANDs as inverters; 4 2-input NANDs})
 \end{aligned}$$

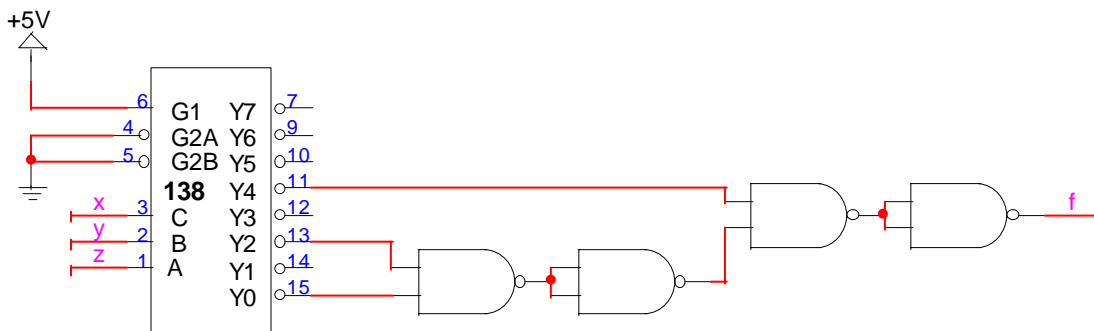

2. Implement a 5:32 binary decoder with active-low enable and active-low outputs using 74LS138 decoders and any glue logic (AND, OR, NOT, etc.) that you desire. Build your circuit using simulation software and verify that it gives the correct output.

Since the '138 has 3 select lines, we must use two other select lines to control the decoder selection. Since each '138 will provide 8 outputs, we will need $32/8 = 4$ decoders to provide all 32 outputs. Using the two most significant select lines to choose between decoders is the easiest.

