

ECE471 INDUSTRIAL POWER SYSTEMS

Test # 3, Winter 2004 - 2005

Name _____

Box # _____

Attempt all five questions.

No partial credit unless you explain your solution procedure.
Write in the space below the question, and on the page facing the question.

Open Notes. Time Allowed - Two Periods.

Question #	Possible Points	Awarded Points
1	20	
2	20	
3	20	
4	20	
5	20	
Total	100	

1.
 - a) The service entrance feeder conductors for a system are 500 MCM copper. Determine the minimum size of the common copper grounding electrode conductor.
 - b) Repeat part (a) if the service entrance feeder conductors are 750 MCM aluminum and the common grounding electrode conductor is copper-clad aluminum.
 - c) A feeder is protected by a 1200 A frame breaker with an 800 A trip unit. Determine the minimum size of the equipment grounding copper conductor.
 - d) Repeat part (c) if the grounding conductor is copper-clad aluminum.

- a) 1/0 Cu
- b) 3/0 Cu-clad Al
- c) 1/0 Cu
- d) 3/0 Cu-clad Al

2.

a) Determine the fault energy and hence state the estimated level of damage if a 250 A arcing ground fault occurs on a feeder protected by a 150 A frame breaker with a 125 A trip unit (figure 8.7). Assume maximum time delay.

b) Repeat part (a) if the ground fault relay initiates the instantaneous trip, which takes 20 ms to operate.

a) 375,000 kW-cycles

b) 30 kW-cycles

3.

In the system shown below, the utility bus has a three-phase fault level of 7285 A with an X/R ratio of 10. The transformer is 500 kVA with 0.7% winding resistance and 7% leakage reactance. The 500 hp motor operates at 85% efficiency and 0.88 lag and has a starting impedance of $0.017 + j0.17$ pu on a 500 kVA base.

- Draw the single-phase equivalent diagram and determine the percent drop in its terminal voltage if the motor is line-started.
- It has been suggested that a starting capacitor bank of 2500 kVAR should be used. Determine what the percent voltage drop will be under these conditions.

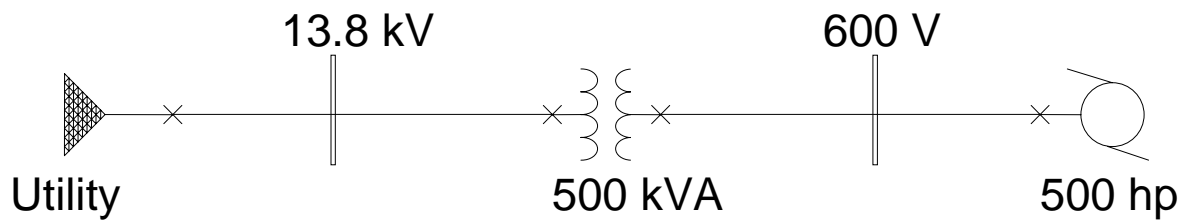

- 30%
- 6.1%

4.

Check the results of question 3 by inputting the system into the PTW software. Assume the single-phase fault level at the utility is 5 kA. If you look at the ANSI Contribution page for the motor you will see that the appropriate data has been entered by default. Attach one-line diagrams with the datablock results for both cases.

a)

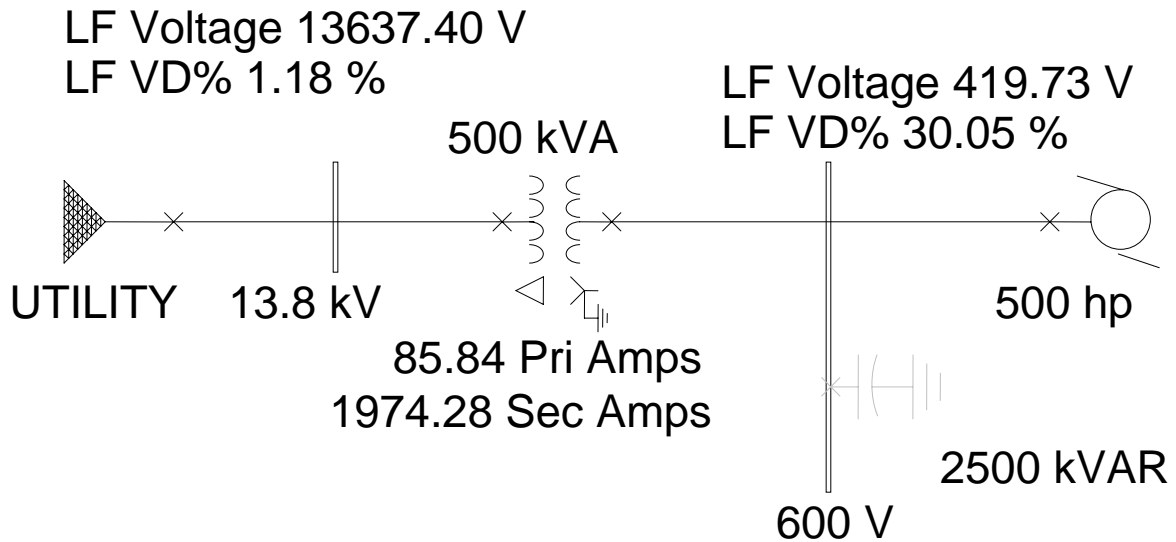

b)

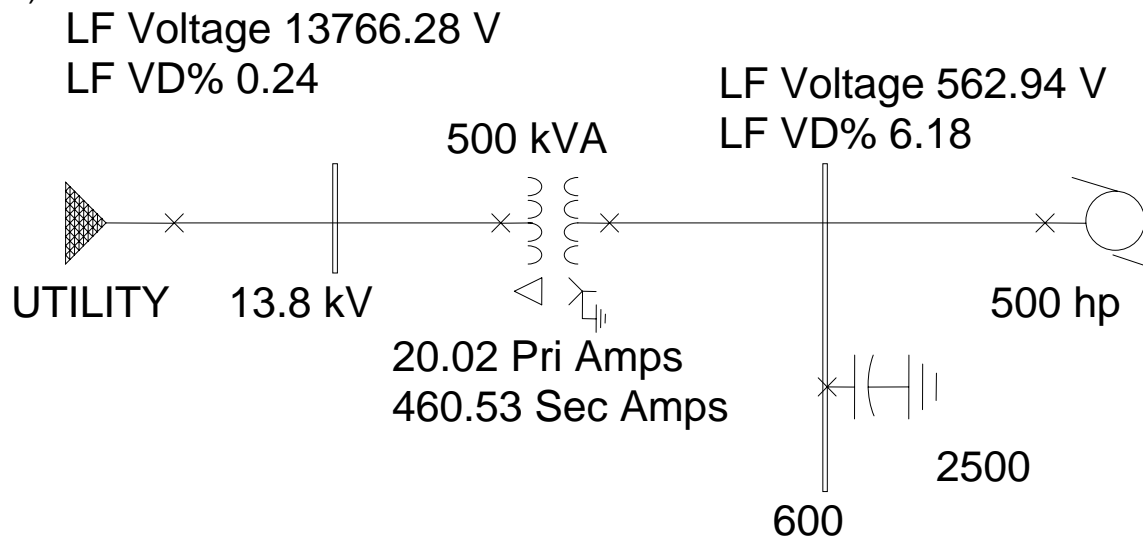

5.

Determine the fault level at the 600 V bus in question 3. Assume that the starting caps have been switched-out and the motor is running normally; this means that the motor contribution in pu is the reciprocal of the starting impedance.

(NOTE: show the hand calculations for the above question – you can use PTW to check your results if you have time.)

$$I_f = 9387 \text{ A}$$

PTW gives the following results. Note that the hand calculations assume the fault contributions are in-phase, while PTW does the full calculation.

