

22.0 Harmonics in Industrial Power Systems

Harmonic frequencies are multiples of the line (fundamental) frequency, which in North America is usually 60 Hz, while it is 50 Hz elsewhere. Figure 1 shows a 60 Hz fundamental sinewave of 1 pu with a third harmonic (180 Hz) of 0.7 pu and a fifth harmonic (300 Hz) of 0.5 pu. Figure 2 shows the resulting waveform.

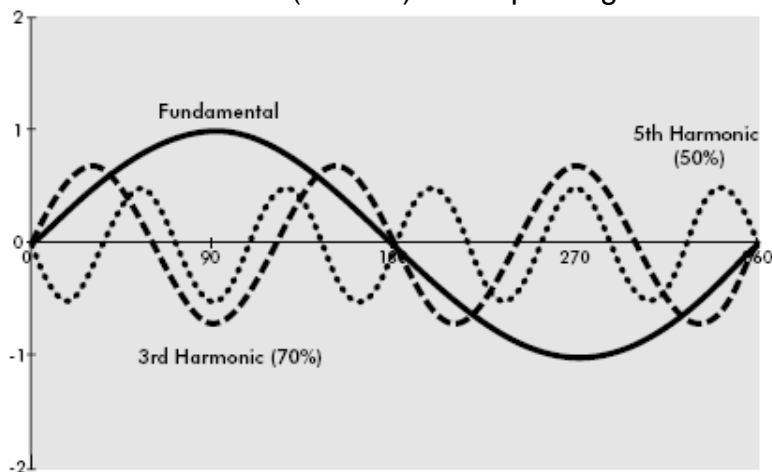

Figure 1 – Harmonic Components
(Both figures are taken from “Harmonics Causes & Effects” by the Copper Development Association)

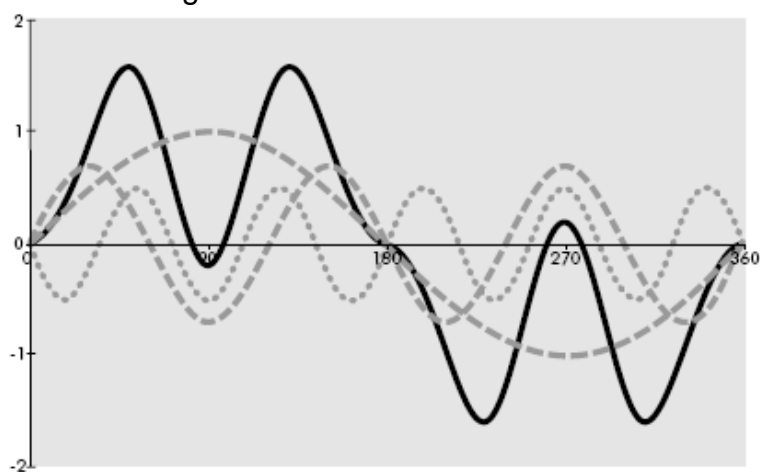

Figure 2 – Resulting Waveform

The resulting waveform is clearly not a sinewave; consequently, any rms calibrated meters will not give correct values; also, there are 6 zero crossings per cycles (instead of 2) so most timing devices will malfunction. In addition, the presence of harmonics will cause overheating.

Current harmonics are usually the biggest concern because they tend to cause the most problems. However, when harmonics propagate around a system, i.e. getting into a branch circuit other than the one carrying the harmonic load current, they do so as voltages; so it is important that the harmonic content of both current and voltage be determined separately. These are usually quoted in terms of Total Harmonic Distortion (THD) with the appropriate “I” or “V”, e.g. 35% THDI and 4% THDV. The THD of a signal is a measurement of the harmonic distortion present and is defined in terms of rms voltages and currents as:

$$\text{THD}_V = \frac{\sqrt{V_2^2 + V_3^2 + V_4^2 + \dots + V_n^2}}{V_1} \quad \text{and} \quad \text{THD}_I = \frac{\sqrt{I_2^2 + I_3^2 + I_4^2 + \dots + I_n^2}}{I_1}$$

Harmonics have been present since power systems were first developed. Magnetic saturation and mercury arc rectifiers were the largest sources for many years. These were not great problems as the level of harmonic content was relatively low and most equipment was not sensitive.

With the advent of power electronics the amount of equipment generating harmonics has risen dramatically (and will continue to rise). The amount of sensitive equipment has also risen and so the effect of harmonics has become intensified.

One thing that is common to all harmonics is that they are created by non-linear loads, i.e. loads whose current vs. voltage characteristics are not a straight line. The next section looks at some of the major types of single-phase and three-phase equipment that cause harmonics.

22.1.1 Single Phase Equipment

The most common source of harmonics on single-phase systems are switched mode power supplies (SMPS) and electronic fluorescent lighting ballasts. Most modern electronic units use SMPS rather than the conventional step-down transformer plus rectifier. Their advantage is that size, cost, and weight are significantly reduced. Their disadvantage is that rather than drawing continuous current from the supply it draws pulses of current that contain harmonic content, as shown in figure 3. The line-to-neutral voltage harmonics can be reduced by fitting filters, but they do not reduce the currents that flow back to the supply. Electronic lighting ballasts enable higher efficiency lamps to be used, but like SMPS they generate harmonics. Also, Compact Fluorescent Lamps (CFL) are being marketed as replacements for tungsten filament bulbs (an 11 W CFL replaces a 60 W filament bulb and lasts for ~8000 hours). The harmonic spectrum of a CFL is shown in figure 4.

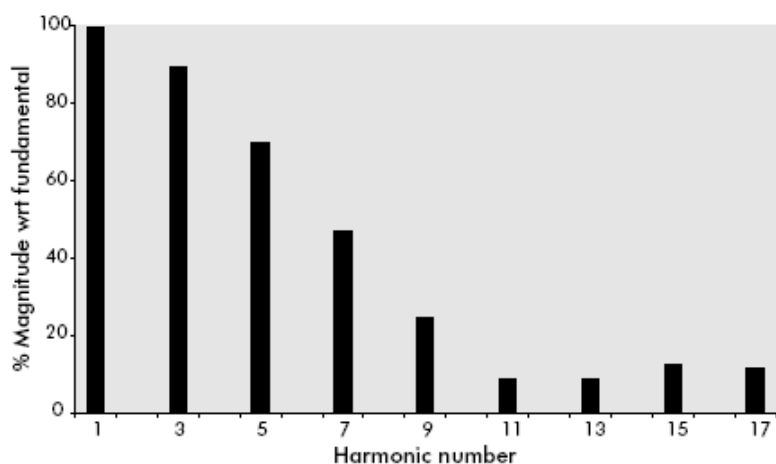

Figure 3 – SMPS Harmonic Components

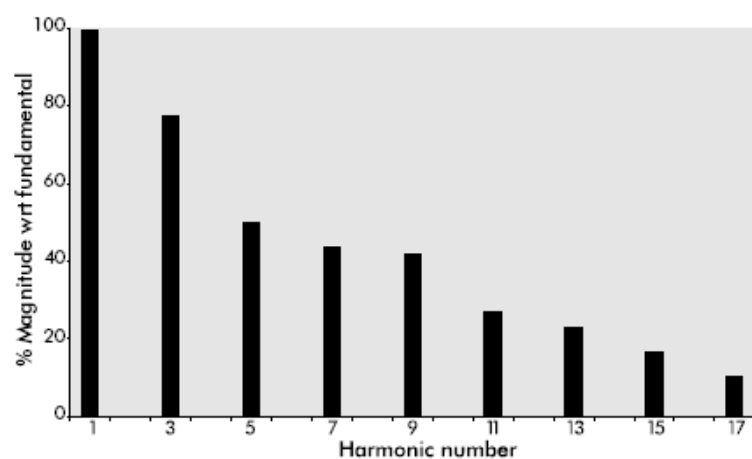

Figure 4 – CFL Harmonic Components

(Both figures are taken from "Harmonics Causes & Effects" by the Copper Development Association)

22.1.2 Three Phase Equipment

The most common source of harmonics on three-phase systems are variable speed drives and large UPS units. Both of these types of equipment are based on the three-phase bridge, shown in figure 5. This produces six pulses per cycle on the dc output.

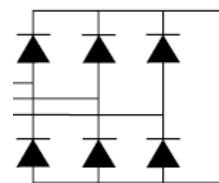

Figure 5 – Six Pulse Bridge

Harmonics are produced at $6n \pm 1$, i.e. at one more and one less than each multiple of six. Fourier Analysis implies that the magnitude of each harmonic is the reciprocal of the harmonic number, i.e. 20% 5th and 9% 11th etc. A typical spectrum is shown in figure 6.

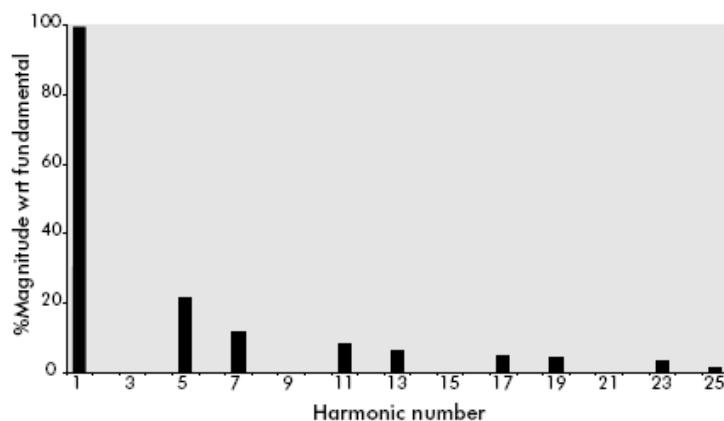

Figure 6 – Six Pulse Bridge Harmonic Spectrum

The magnitude of the harmonics is significantly reduced by applying a twelve-pulse bridge, which utilizes the 30° phase-shift between wye and delta secondary's of a three-winding transformer as shown in figure 7.

Theoretically harmonics are produced at $12n \pm 1$ and the $6n$ harmonics are removed, this is rarely achieved in practice and reductions to 3% or so are typical resulting in the spectrum shown in figure 8.

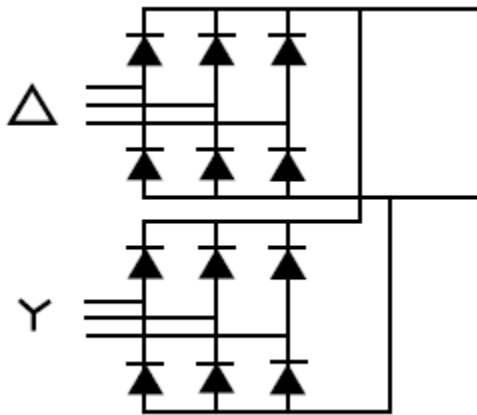

Figure 7 – Twelve Pulse Bridge

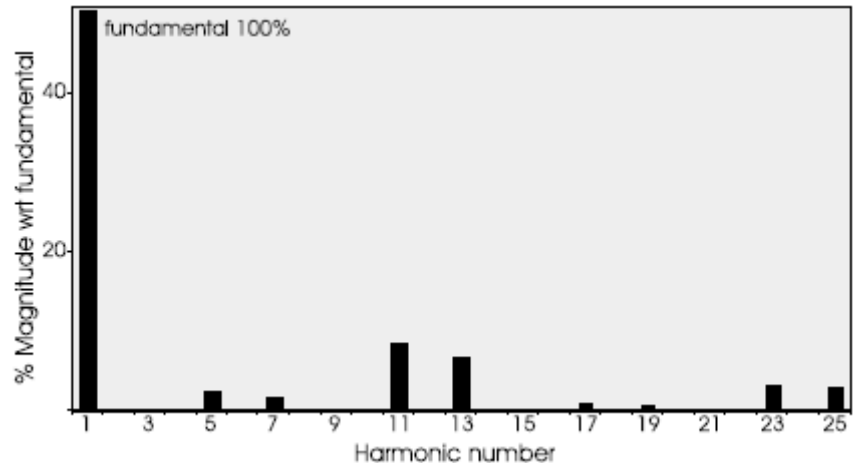

Figure 8 – Twelve Pulse Bridge Harmonic Spectrum

(Both figures are taken from "Harmonics Causes & Effects" by the Copper Development Association)

22.2 How Harmonics are Generated

In an ideal power system a sinusoidal voltage produces a sinusoidal current and vice versa. This results from straight load-line relationship as shown in figure 9, which relates the magnitudes of voltage and current. Note that if the load contains inductance or capacitance there will also be a phase-shift that is not shown in figure 9.

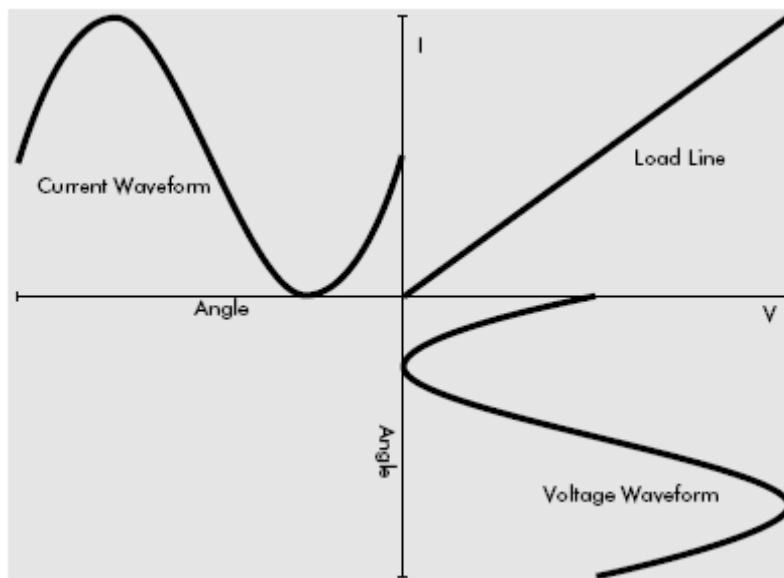

Figure 9 – Load Line of a Linear Load

(Taken from "Harmonics Causes & Effects" by the Copper Development Association)

The load-line of a non-linear load, such as a full-wave rectifier and smoothing capacitor is shown in figure 10. Current only flows when the supply voltage exceeds that of the reservoir capacitor i.e. close to the peak voltage.

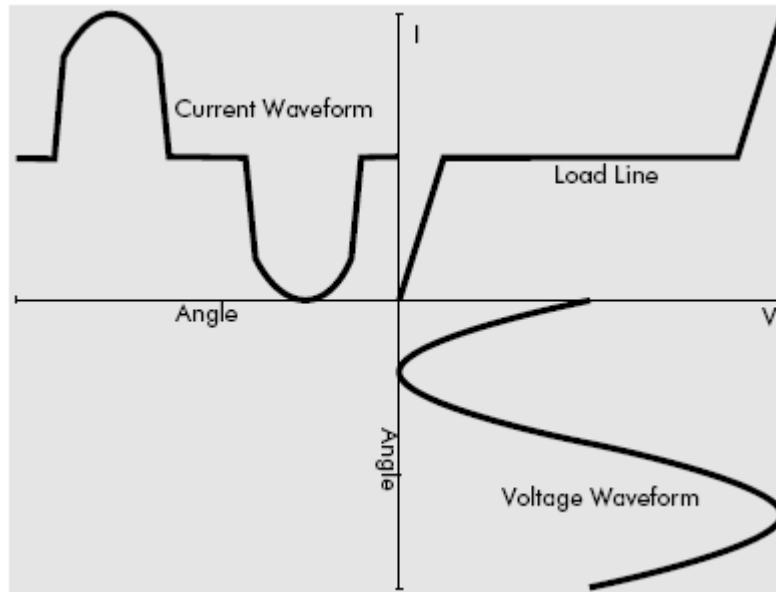

Figure 10 – Load Line of a Non-Linear Load
(Taken from “Harmonics Causes & Effects” by the Copper Development Association)

Fourier Analysis enables the current waveform to be represented by its harmonic frequencies. Recall that for symmetrical waveforms even harmonics are zero; this is why even harmonics are very rare in power systems.

The equivalent circuit for a non-linear load like this can be represented by a linear load in parallel with a number of current sources, each one producing a harmonic frequency as shown in figure 11.

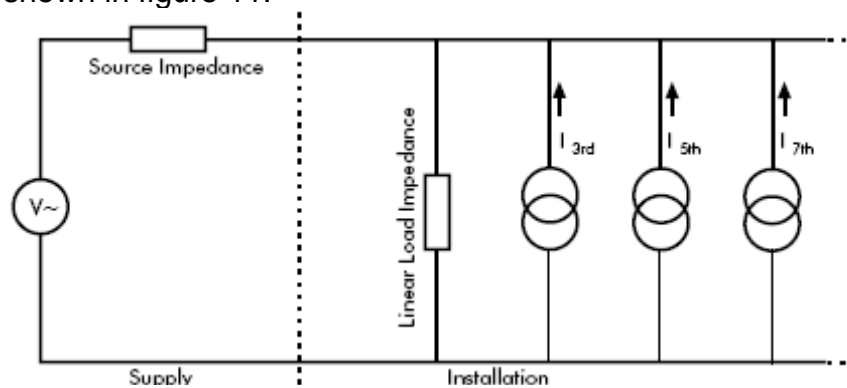

Figure 11 – Equivalent Circuit of a Non-Linear Load
(Taken from “Harmonics Causes & Effects” by the Copper Development Association)

The harmonic currents have to flow around the circuit via the source impedance; as a result, harmonic voltage drops appear across the supply impedance. Because source impedances are low the resulting voltage distortion is low and if only voltage harmonics are measured this may give the (wrong) impression that there are no harmonic problems when in fact large harmonic currents are present.

22.3 Problems Caused by Harmonics

Harmonics cause problems in both the industrial installation and also on the power supply system. It is worth noting that some measures taken to reduce the effect of harmonics on the industrial plant may not reduce the harmonics fed back to the power system and vice versa.

22.3.1 Harmonic Problems within an Industrial Power Plant

The main problems associated with harmonic currents are:

- Overloading of neutrals is caused because 3rd (and any *triple – N*) harmonics do not have 120° phase shifts and so add instead of cancelling in the neutral.
- Overheating of transformers is caused mainly by eddy currents, which are normally about 10% of the total losses at full-load but increase dramatically with harmonic number and can cause the total losses to double if the load is made up entirely of components like SMPS. Also, triple – N harmonics will circulate around delta windings, increasing losses.
- Nuisance tripping of ground fault circuit breakers due to high levels of noise associated with equipment that generate harmonics.

The main problems associated with harmonic voltages are:

- Voltage distortion caused by the harmonic currents producing a harmonic voltage drop on the source impedance. Because the voltage at the service entrance is corrupted, all loads (even linear loads) will see a harmonic supply and will produce harmonic currents. Note that UPS have much higher impedances than the utility supply.
- Induction motors will see an increase in eddy current losses just like transformers. Additional losses arise because the harmonics try to rotate the motor at a different speed – possibly in the reverse direction!!
- Zero-crossing noise.

22.3.2 Harmonic Problems on the Power Supply System

When harmonic currents are drawn by an industrial load they cause a harmonic voltage drop equal to the product of the source impedance and the current. Since the supply network is highly inductive, the source impedance is higher at higher frequencies. Different State Regulatory Agencies have differing regulations concerning how much harmonic content is permitted.

22.4 Harmonic Mitigation Measures

Harmonic mitigation methods fall broadly into three groups: passive filters, isolation transformers, and active filters.

22.4.1 Passive Filters

Passive filters provide a low impedance path for harmonic currents, so that they flow in the filter and not in the supply, as shown in figure 12. Such filters may be tuned to a single harmonic or a band of harmonics. Sometimes a series filter is also required to increase the impedance seen by the harmonic and so reduce the current that flows back into the utility supply, as shown in figure 13.

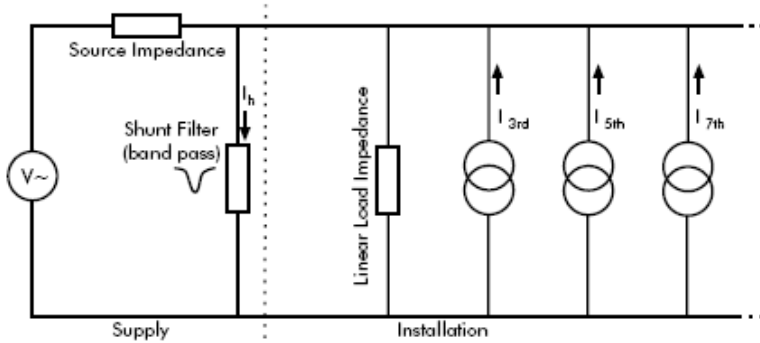

Figure 12 – Passive Harmonic Shunt Filter

(Both figures are taken from "Harmonics Causes & Effects" by the Copper Development Association)

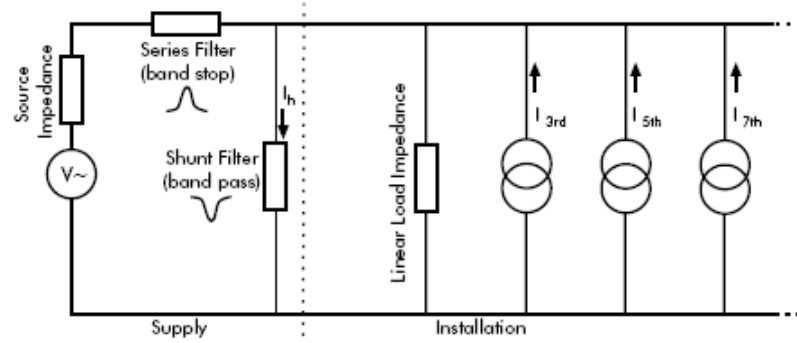

Figure 13 – Passive Shunt & Series Filters

22.4.2 Isolation Transformers

The fact that triple – N harmonics circulate within a delta means that the transformer has to be de-rated to account for the extra current in the windings. However, once this is done the effect is beneficial because the delta prevents the triple – N harmonics from entering the supply, as shown in figure 14.

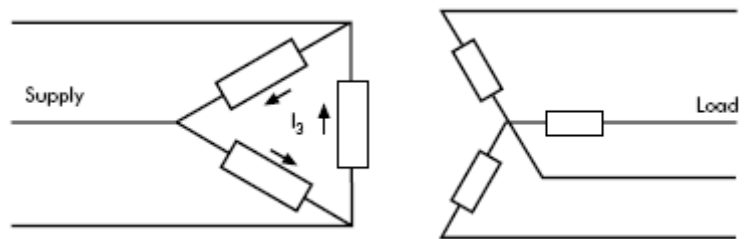

Figure 14 – Delta – Wye Isolation Transformer

22.4.3 Active Filters

Passive filters only trap their designed harmonic(s), while isolation transformers only stop triple – N harmonics. In many modern installations the equipment mix is constantly changing resulting in a *drifting* of the harmonic spectrum. Active filters are often useful in these circumstances. They are shunt devices in which the harmonic content is measured on one cycle and an exact replica is produced from within the conditioner and fed onto the supply on the next cycle. Since the harmonic current is drawn from the conditioner, only fundamental current is drawn from the supply. In practice about 90% of the harmonics are removed.

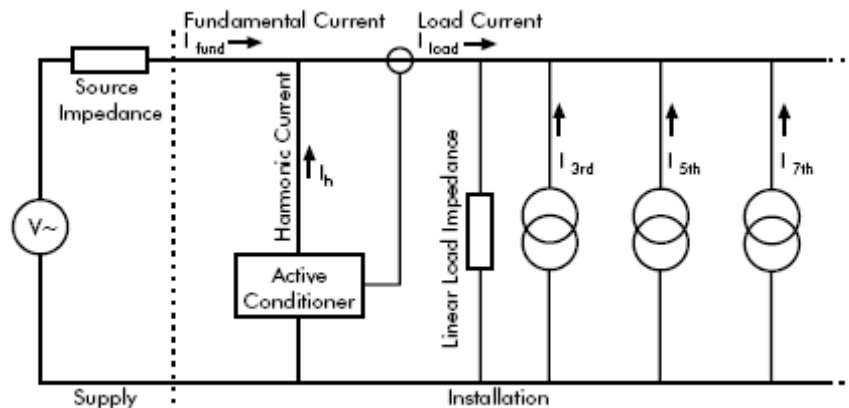

Figure 15 – Active Harmonic Filter

(Taken from "Harmonics Causes & Effects" by the Copper Development Association)

Harmonics Quiz

- Which series of frequencies are the **least** likely to be encountered in a North American power distribution system:
a) 180 Hz, 300 Hz, 420 Hz b) 120 Hz, 240 Hz, 360 Hz c) 300 Hz, 420 Hz, 660 Hz
- Which load does not normally produce significant harmonic currents:
a) Personal Computer b) Television c) Induction Motor d) Fluorescent lamp
- The SMPS shown in figure 3 has a THDI on the order of:
a) < 1% b) 1 – 10% c) 10 – 100% d) > 100%
- The CFL shown in figure 4 has a THDI on the order of:
a) < 1% b) 1 – 10% c) 10 – 100% d) > 100%
- A three-phase bridge rectifier produces harmonics that flow in the neutral
a) Wrong - a three-phase bridge doesn't have a neutral b) Correct
- A three-phase bridge rectifier produces the following harmonics:
a) 3rd 5th 7th b) 2nd 3rd 4th c) 3rd 9th 15th d) 5th 7th 11th
- What is the most harmful in terms of transformer overheating
a) Voltage Harmonics b) Current Harmonics c) Both equally harmful
- A clock radio starts to gain time – what is the likely cause?
a) Voltage distortion b) Voltage magnitude too high c) Resonance with the source
- Which statement is wrong?
a) Passive filters are tuned for each significant harmonic
b) Active filters are tuned for each significant harmonic
- An isolation transformer blocks:
a) Even harmonics b) Odd harmonics c) Triple – N harmonics