

ECE 470 POWER SYSTEMS I

Final Exam - Fall 2000

NAME _____

BOX # _____

Attempt all five questions.

NO PARTIAL CREDIT will be given for incorrect answers without a full explanation of the solution procedure followed.

Open Book. Time allowed - Four Hours

Question #	Possible Points	Awarded Points
1	25	
2	15	
3	25	
4	20	
5	15	
Total	100	

1. The single-line diagram of a 3 ϕ power system is shown below. The system data, on equipment rating bases are:

G1	13.8 kV	20 MVA	$X_1= 0.2$	$X_2= 0.2$	$X_o= 0.05$	$X_n=0.0$
G2	18kV	30 MVA	$X_1= 0.2$	$X_2= 0.2$	$X_o= 0.05$	
G3	20kV	30 MVA	$X_1= 0.165$	$X_2= 0.165$	$X_o= 0.041$	$X_n=0.041$
G4	20kV	25 MVA	$X_1= 0.165$	$X_2= 0.165$	$X_o= 0.041$	
T1	13.8/220kV	25 MVA	$X = 10\%$			
T2	18/127kV	10 MVA	$X = 10\%$	$3 \times 1 \square$ units		
T3	22/220 kV	35 MVA	$X = 10\%$			
T4	22/220 kV	35 MVA	$X = 10\%$			
L1-2	220 kV		$X_1= 80 \Omega = X_2$		$X_o= 210 \Omega$	
L1-3	220 kV		$X_1= 100 \Omega = X_2$		$X_o= 250 \Omega$	
L2-3	220 kV		$X_1= 80 \Omega = X_2$		$X_o= 210 \Omega$	

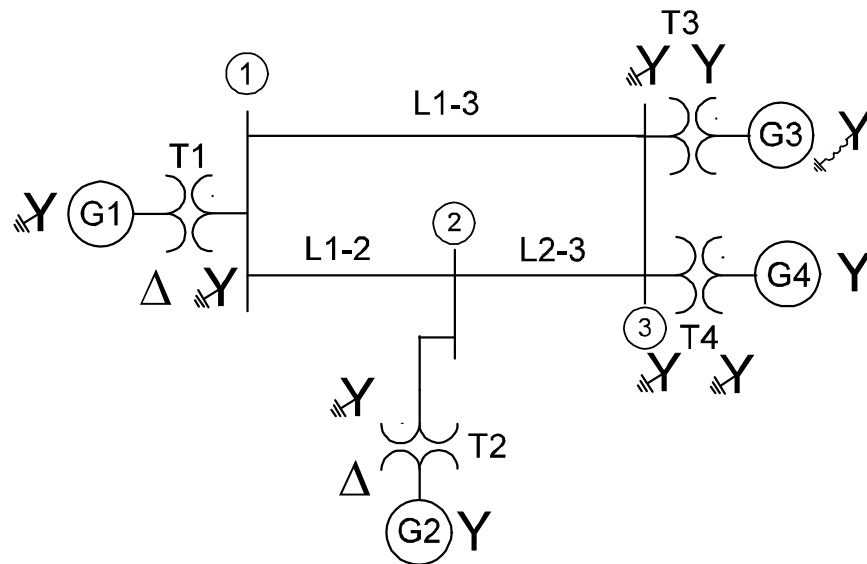

Draw the positive-, negative-, and zero-sequence impedance diagrams using 100 MVA, 220 kV base in the zone of each line.

2. All machines in problem 1 have 1.1 pu excitation. For faults at bus 1, and based on your answer to problem 1 determine the Thevenin equivalents of the positive, negative and zero sequence networks.

$$V_{T1} = 1.1 \text{ pu}, \quad X_1 = 0.2996, \quad X_2 = 0.2996, \quad X_0 = 0.2448$$

3. Based on your answers to problems 1 & 2, evaluate the phase voltages and phase currents (pu) for the following faults:
- a) 3ϕ -G b) 1ϕ -G c) 2ϕ d) 2ϕ -G

Fault Currents (pu) are:

- a) 3.672
b) 3.91
c) 3.18

4.

The existing 3 ϕ and 1 ϕ -G fault levels at bus 11 are: 10 pu and 12 pu respectively. The system planning department are considering installing additional generation at bus 11 via a transformer with $X_1 = X_2 = X_0 = 0.05$ pu; the new generator sub-transient reactances are $X_1 = X_2 = 0.2$ pu, $X_0 = 0.05$ pu. Assume all excitation voltages are 1.0 pu.

- a) Determine the positive, negative and zero sequence Thevenin equivalents at bus 11 prior to the addition.
- b) What will be the 3 ϕ , 1 ϕ -G fault levels at bus 11 after the generator and transformer have been installed?
- c) Re-do part (b) with the transformer's configuration $\Delta - \Delta$.

b) 14 and 17.03 pu

c) 15.56 pu

5.

- a) Calculate the allowable body current which can be safely withstood for 0.35 sec by a person weighing 50 kg, and hence determine the allowable touch potential when this person is standing on unsurfaced ground whose resistivity is 40 Ω .m. ($C_s = 1.0$)
 - b) The conditions in part (a) apply to a building which is grounded at a single earth electrode having a diameter of 2.5 cm and is 3.5 m long. The highest ground fault is 100 A, which will be cleared in 0.35 sec. Compare the allowable and actual touch potentials and determine if the grounding system is adequate.
 - c) Rework parts (a) and (b) if the ground is to be covered with 10 cm of asphalt with resistivity of 5000 Ω .m. ($C_s \neq 1.0$)
-
- b) Not adequate by 427%
 - c) Adequate by 5.7%