

Problems

Problem 4.1

When the power to an electric motor is turned on, the motor reaches its rated speed of 3300 rpm in 6 s, and when the power is turned off, the motor coasts to rest in 80 s. Assume uniformly accelerated motion. Determine the number of revolutions that the motor executes in a) reaching its rated speed, b) coasting to rest.

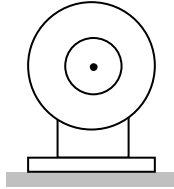

Problem 4.2

Two blocks and a pulley are connected by inextensible cords as shown. The pulley has an initial angular velocity of $\omega = 0.8$ rad/s counterclockwise and a constant angular acceleration of $\alpha = 1.8$ rad/s² clockwise. After 5 s of motion, determine the velocity and position of block A and block B.

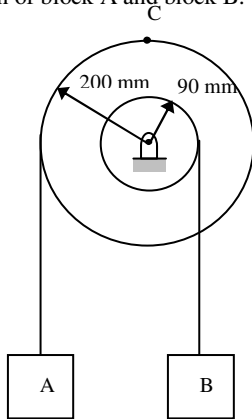

Problem 4.3

Three bars, each weighing 8 lbs, are welded together and are pin-connected to links BE and CF. The weight of the links can be neglected (this means that each link can be considered as a 2-force member, that is, the force acts along the link). If the system is released from rest, determine the force in each link immediately after release.

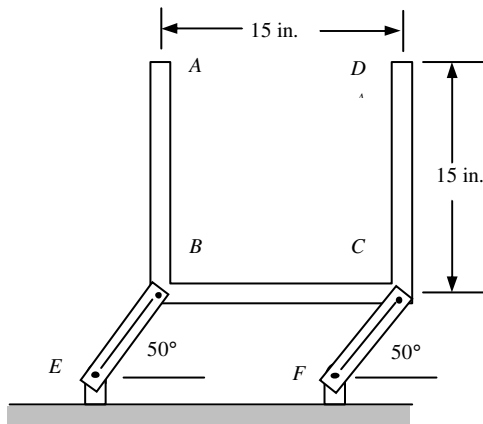

Problem 4.4

Disk A has a mass of 6 kg and an initial angular velocity of 360 rpm clockwise; disk B has a mass of 3 kg and is initially at rest. The disks are brought together by applying a horizontal force of magnitude 20 N to the axle of disk A. The coefficient of kinetic friction between the disks is $\mu_k = 0.15$. Bearing friction can be neglected. Determine:

- the angular acceleration of each disk,
- the final angular velocity of each disk.

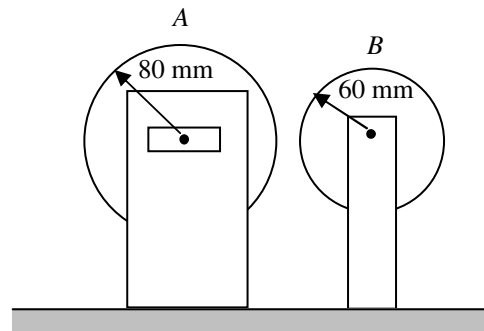

Problem 4.5

A 1.5 kg slender rod is welded to a 5 kg uniform disk as shown. The assembly swings freely about C in a vertical plane. In the position shown, the assembly has an angular velocity of $\omega = 10$ rad/s clockwise. Determine a) the angular acceleration of the assembly, and b) the components of the reaction at C.

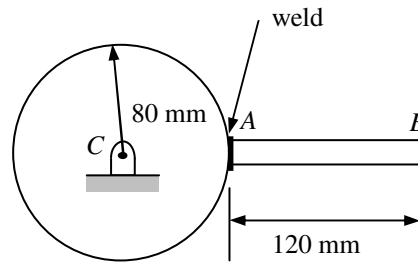

Problem 4.6

A slender 4 kg rod can rotate in a vertical plane about a pivot at *B*. A spring having a constant of $k = 400 \text{ N/m}$ and unstretched length of $l = 150 \text{ mm}$ is attached to the rod as shown. The rod is released from rest in the position shown. Determine the angular velocity of the rod after it rotates through 90° .

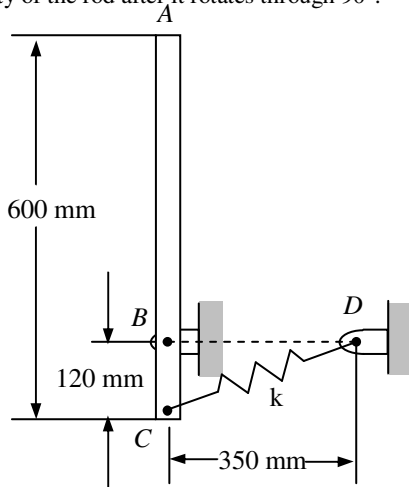

Problem 4.7

A 45-g bullet is fired with a horizontal velocity of 400 m/s into a 9-kg panel of side $b = 0.2 \text{ m}$. Knowing that $h = 190 \text{ mm}$ and that the panel is initially at rest, determine

- the velocity of the center of the panel immediately after the bullet becomes imbedded,
- the impulsive reaction at *A*, assuming that the bullet becomes imbedded in 2 ms.
- the reaction at *A* after the plate has swung through an angle of 90 degrees

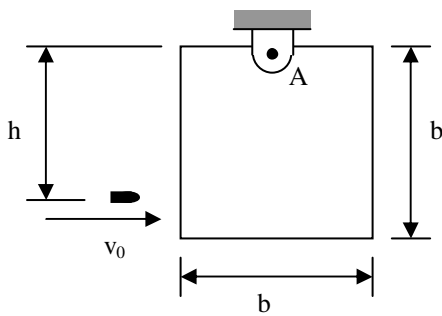

Problem 4.8

A 3-in.-radius drum is rigidly attached to a 5-in.-radius drum as shown. One of the drums rolls without sliding on the surface shown, and a cord is wound around the other drum. End *E* of the cord is pulled to the left with a velocity of $v = 6 \text{ in/s}$. Determine:

- angular velocity of the drums
- velocity of the center of the drums
- length of cord wound or unwound per second.

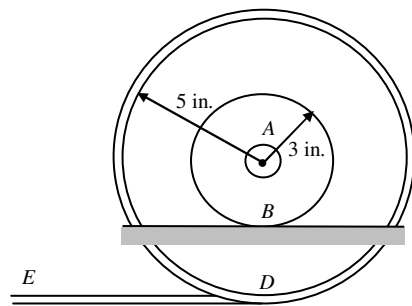

Problem 4.9

At the instant shown, the angular velocity of rod *AB* is $\omega = 15 \text{ rad/s}$ clockwise. Determine:

- Angular velocity of rod *BD*
- Velocity of the midpoint of rod *BD*

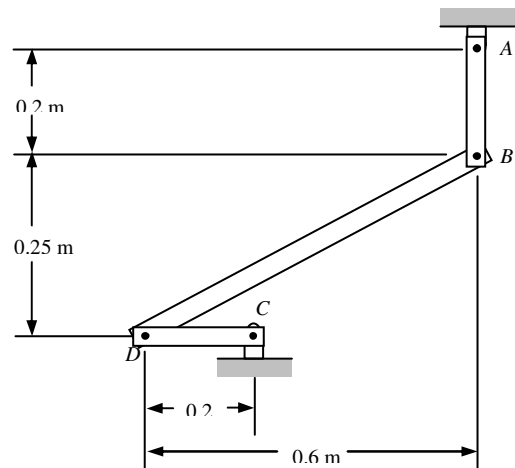

Problem 4.10

A slender rod of length l is pivoted about a point C located at a distance b from its center G . It is released from rest in a horizontal position and swings freely. Determine:

- a) The distance b for which the angular velocity of the rod as it passes through a vertical position is maximum
- b) Corresponding values of its angular velocity and of the reaction at C .

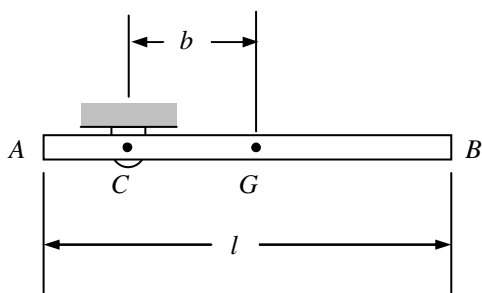

Problem 4.11

Rod BC ($m = 5$ kg) is attached by pins to two uniform disks as shown. The mass of the 150-mm-radius disk is 6 kg, and that of the 75-mm-disk is 1.5 kg. The system is released from rest in the position shown, the disks roll without slipping on the ground and a constant moment, $M = 2$ N-m is applied to the larger disk as shown. Determine the velocity of the center of gravity of the rod after disk A has rotated through 90° .

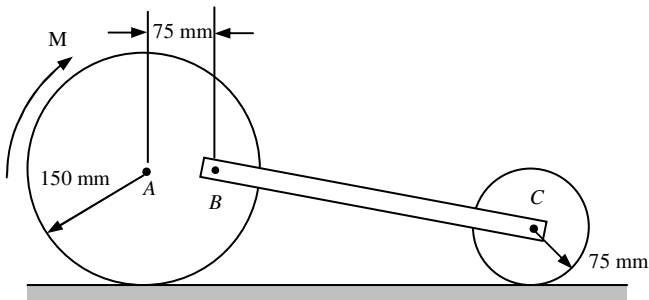

Problem 4.12

The uniform rods AB and BC weigh 2.4 pounds and 4 pounds, respectively. Assume the small wheel at C is of negligible weight. Determine the velocity of the pin B after rod AB has rotated through 90° .

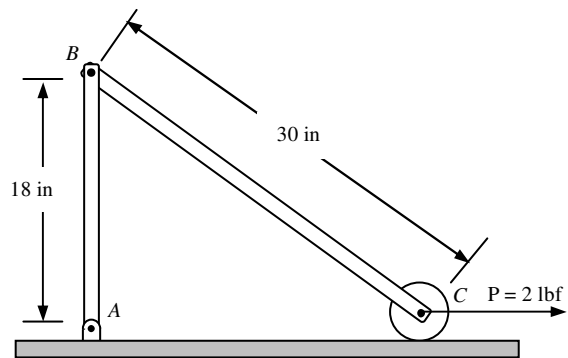

Problem 4.13

The 80-mm-radius gear shown below has a mass of 5 kg and a centroidal radius of gyration of 60 mm (the gear teeth are left off the drawing because they are a pain to draw). The 4-kg rod AB is attached to the center of the gear and to a pin at B that slides freely in a vertical slot. Knowing that the system is released from rest when $\theta = 60^\circ$, determine the velocity of the center of the gear, A , when $\theta = 0$.

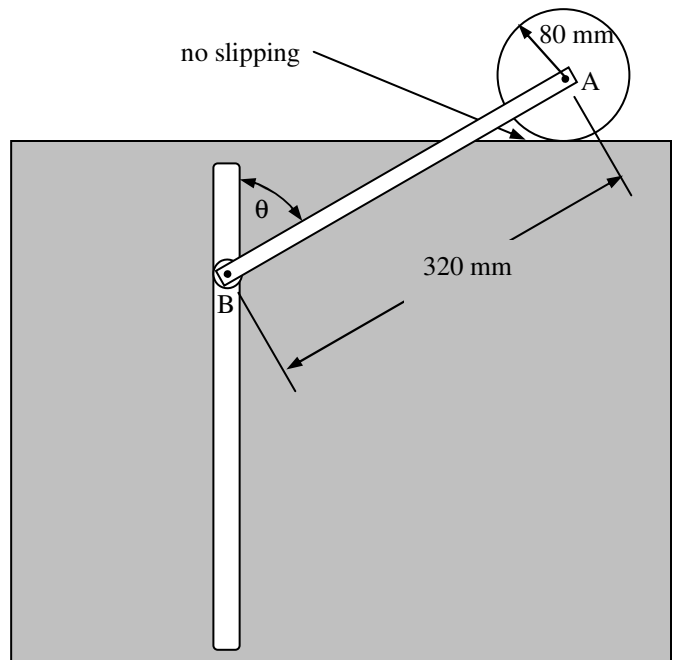

Problem 4.14

At what height h above its center G should a billiard ball of radius r be struck horizontally by a cue if the ball is to start rolling without sliding?

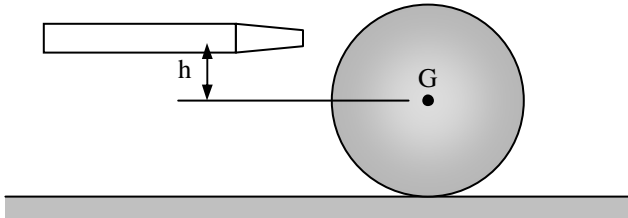
**Problem 4.15**

The uniform rectangular block shown below is moving along a frictionless surface with a velocity v_1 when it strikes a small obstruction at B . Assuming that the impact between corner A and obstruction B is perfectly plastic, determine the magnitude of the velocity v_1 for which the maximum angle θ through which the block will rotate is 30° .

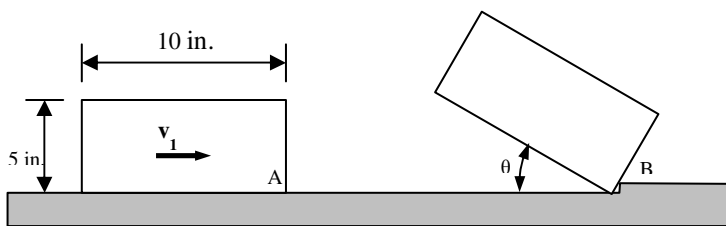
**Problem 4.16** (Taken from Engineering Mechanics: Dynamics by Meriam and Kraige)

Each of the two 300-mm rods A has a mass of 1.5 kg and is hinged at its end to the rotating base B . The 4-kg base has a radius of gyration of 40 mm and is initially rotating freely about its vertical axis with a speed of 300 rev/min and with the rods latched in the vertical positions. If the latches are released and the rods assume the horizontal positions, calculate the new rotational, N , speed of the assembly in rev/min.

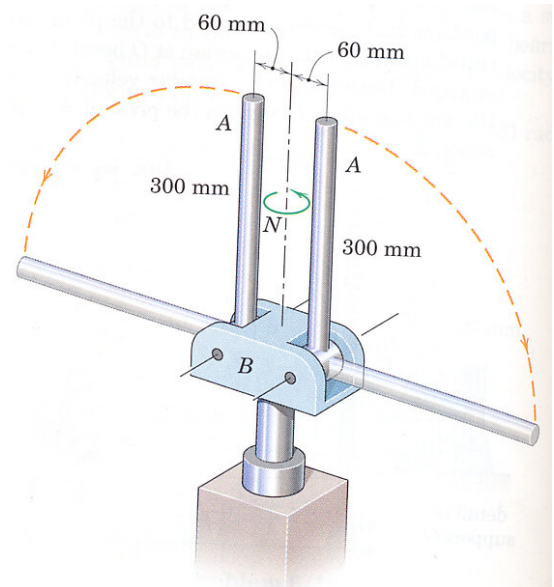
**Problem 4.17**

The 6-lb steel sphere A and the 10-lb wooden cart B are at rest in the position shown below when the sphere is given a slight nudge, causing it to roll without sliding along the top surface of the cart. Assume the friction between the cart and the ground is negligible. Determine the velocity of the cart as the sphere passes through the lowest point of the surface at C . Note: assume the radius of the sphere is r . Your final answer should not depend on r .

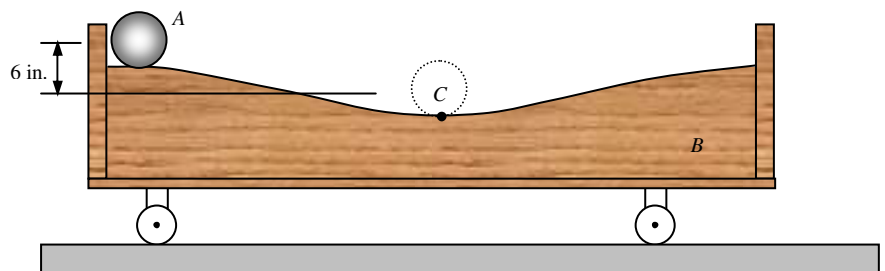

Problem 4.18

A 900-mm rod rests on a horizontal table. A force P applied as shown produce the following accelerations: $a_A = 3.6 \text{ m/s}^2$ to the right, $\alpha = 6 \text{ rad/s}^2$. Determine the point on the rod that a) has no acceleration, b) has an acceleration of 2.4 m/s^2 to the right.

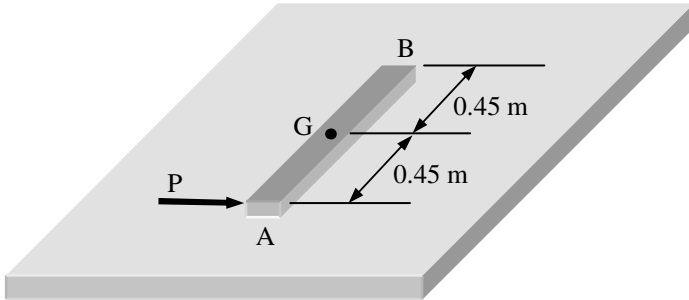

Problem 4.19

An automobile travels to the left at a constant speed of 48 mi/h. Knowing that the diameter of the wheel is 22 in., determine the acceleration a) of point B, b) of point C, c) of point D.

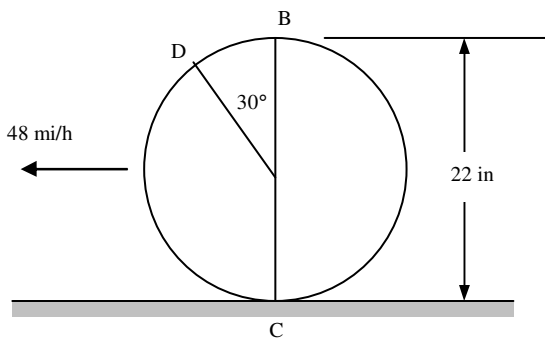

Problem 4.20

The endpoints of the bar slide on the plane surfaces. Show that the acceleration of the midpoint G is related to the bar's angular velocity and angular acceleration by

$$\bar{a}_G = \frac{L}{2} [(\alpha \cos \theta - \omega^2 \sin \theta) \hat{i} - (\alpha \sin \theta + \omega^2 \cos \theta) \hat{j}]$$

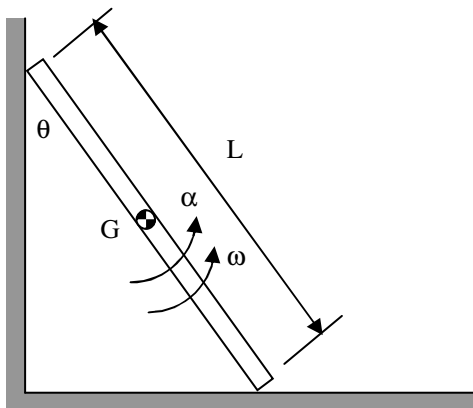

Problem 4.21

Knowing that crank AB rotates about point A with a constant angular velocity of 900 rpm clockwise, determine the acceleration of the piston P when $\theta = 120^\circ$.

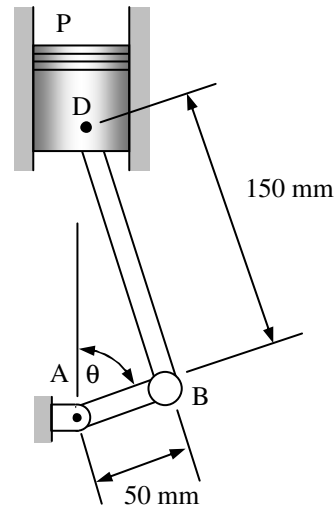

Problem 4.22

Knowing that at the instant shown rod AB has a constant angular velocity of 6 rad/s clockwise, determine a) the angular acceleration of member BDE , b) the acceleration of point E .

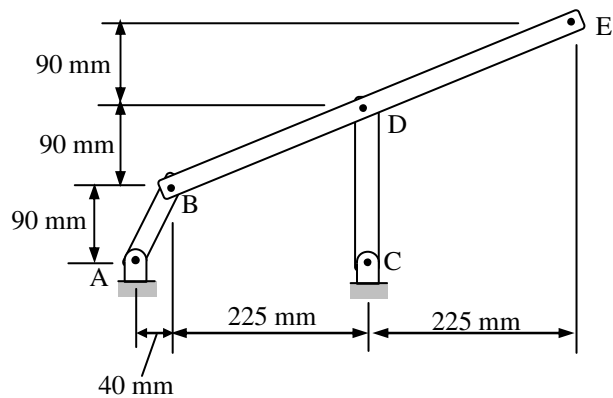

Problem 4.23

A uniform slender rod AB rests on a frictionless horizontal surface, and a force P of magnitude 0.25 lb is applied at A in a direction perpendicular to the rod. Knowing that the rod weighs 1.75 lb, determine the acceleration of a) point A , b) point B .

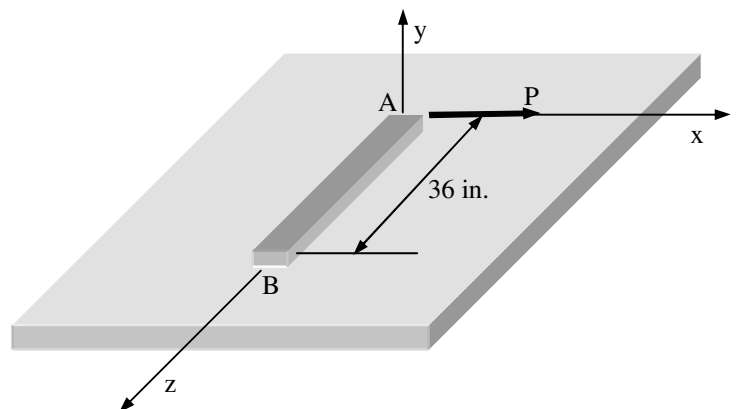

Problem 4.24

The 3-oz yo-yo shown has a centroidal radius of gyration of 1.25 in. The radius of the inner drum on which a string is wound is 0.25 in. Knowing that at the instant shown the acceleration of the string is 3 ft/s^2 upward, determine a) the tension in the string, b) the corresponding angular acceleration of the yo-yo.

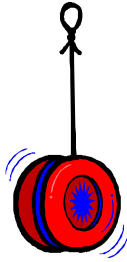
**Problem 4.25**

A bowler projects an 8-in diameter ball weighing 12 lb along an alley with a forward velocity of 15 ft/s and a backspin of 9 rad/s. Knowing that the coefficient of kinetic friction between the ball and the alley is 0.10, determine

- the initial acceleration of the center of gravity of the ball
- the initial angular acceleration of the ball
- the time t_1 at which the ball will start rolling without slipping
- the speed the ball at time t_1
- the distance the ball will have traveled at time t_1
- the friction force immediately after the ball starts rolling without slipping.

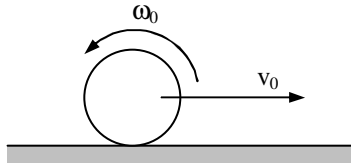
**Problem 4.26**

A drum of 60-mm radius is attached to a disk of 120-mm radius. The disk and drum have a total mass of 6 kg and a combined radius of gyration of 90 mm. A cord is attached as shown and pulled with a force P of magnitude 20N. Knowing that the disk rolls without slipping, determine

- the angular acceleration of the disk and the acceleration of G
- the minimum value of the coefficient of friction compatible with this motion.

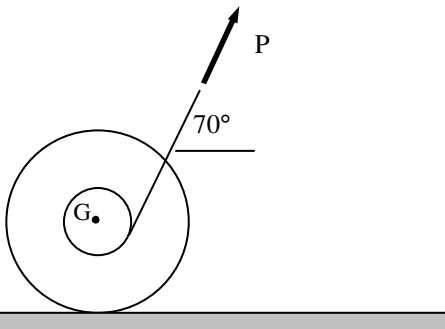
**Problem 4.27**

A uniform slender bar AB of mass m is suspended as shown from a uniform disk of the same mass m . Assuming the disk rolls without slipping on the ground, determine the accelerations of points A and B immediately after a horizontal force P has been applied at B .

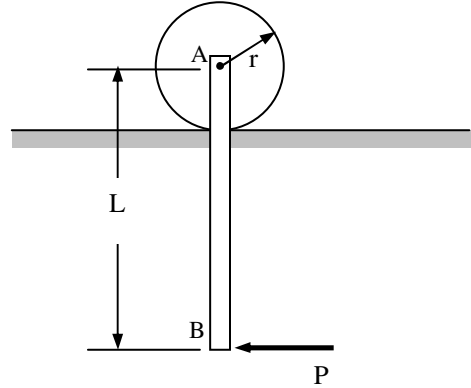
**Problem 4.28**

A meterstick having a mass of 0.1 kg is released from rest in the position shown. Model the meterstick as a slender bar and assume it is released from rest at $\theta_0 = 30^\circ$ and all surfaces are frictionless.

Determine

a) the normal force between the stick and the vertical wall at any angle θ .

To check your answer:

when $\theta = 30^\circ$ you should get $\alpha = 7.36 \text{ rad/s}^2$, and $N_B = 0.32 \text{ N}$
 when $\theta = 40^\circ$ you should get $\alpha = 9.46 \text{ rad/s}^2$, and $N_B = 0.27 \text{ N}$

b) Determine the angle the bar will leave the wall assuming the bar is released from rest at angle $\theta_0 = 30^\circ$ (i.e. at what angle will the normal force between the vertical wall and the yardstick to zero). It is helpful to determine the normal force and plot it as a function of θ to get a feel for when it will be zero. Include this plot in your solution.

c) Use Working Model determine the angle the bar will leave the wall. Be sure to use all the same parameters as used in part b). In your WM simulation define a measure giving the normal force between the wall and the meterstick by selecting both objects and then going to the "Measure" menu and selecting "contact force". Include a snapshot of the simulation at the moment the meterstick leaves the wall.

d) Compare your results from part b) and c)

Hints:

1) You need the angular velocity for any angle θ . The easiest way is to determine this is to use conservation of energy between some starting angle θ_0 and some final angle θ . You should be

able to obtain $\omega = \sqrt{\frac{3g}{L}(\cos \theta_0 - \cos \theta)}$. To save time in solving this problem you may assume this relationship is given (just be sure that you could derive it if asked!)

2) You'll need the acceleration of the center of gravity as a function of θ which you found in problem 20.3 to be

$$\bar{a}_G = \frac{L}{2} [(\alpha \cos \theta - \omega^2 \sin \theta) \hat{i} - (\alpha \sin \theta + \omega^2 \cos \theta) \hat{j}]$$

You do not need to rederive this if you have already done this problem.

3) In your Working Model solution make sure friction is zero.

3) Use Maple to solve the set of equations that you will get.

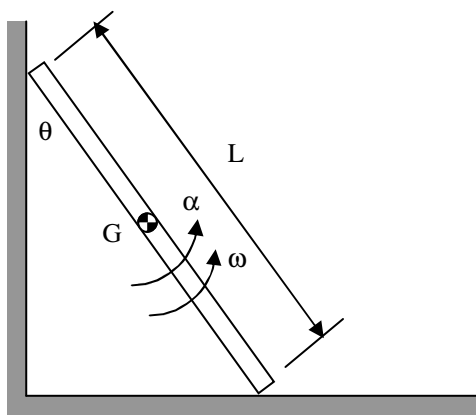

Problem 4.29

A driver starts his car with the door on the passenger's side wide open ($\theta = 0$). The 80 lb door has a centroidal radius of gyration of 12.5 in and its mass center is located at a distance $r = 22$ in. from its vertical axis of rotation, A. Knowing that the driver maintains a constant acceleration of 6 ft/s^2 . Determine the angular velocity of the door as it slams shut ($\theta = 90^\circ$).

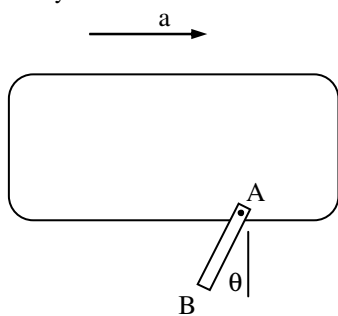

Problem 4.30

In the engine system shown $L = 250 \text{ mm}$ and $b = 100 \text{ mm}$. The connecting rod BD is assumed to be a 1.2 kg uniform slender rod and is attached to the 1.8 kg piston P. During a test of the system, crank AB is made to rotate with a constant angular velocity of 600 rpm clockwise with no force applied to the face of the piston. Determine the forces at B and D on the connecting rod as functions of θ and make plots of B_x , B_y , D_x and D_y . The figure shown is a top view so you will not have the weights on the FBDs.

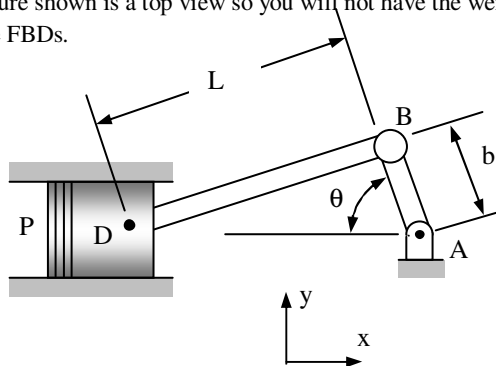

Hints:

- You will need to write your position vectors for some general angle θ .
- In order for crank AB to rotate at a constant angular velocity there must be a moment applied to it, so do not pick AB as one of your systems since you are not asked to determine this moment.
- Using kinematics you should be able to determine the acceleration of the center of gravity of BD so the only systems you will need to use are bar BD and the piston (both by themselves).

An answer to check your Maple worksheet is shown below: When $\theta = 180^\circ$ the forces are: $B = 805 \text{ N}$ (left), $D = 426 \text{ N}$ (right). A plot of B_x as a function of θ is shown to the right.

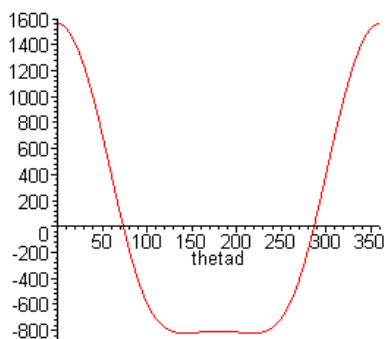

Problem 4.31 (from *Vector Mechanics for Engineers: Dynamics* by Beer and Johnston)

Two rotating rods are connected by slider block P. The rod attached at A rotates with a constant angular velocity of 10 rad/s clockwise. Determine:

- the angular velocity of the rod attached at B,
- the relative velocity of slider block P with respect to the rod on which it slides.

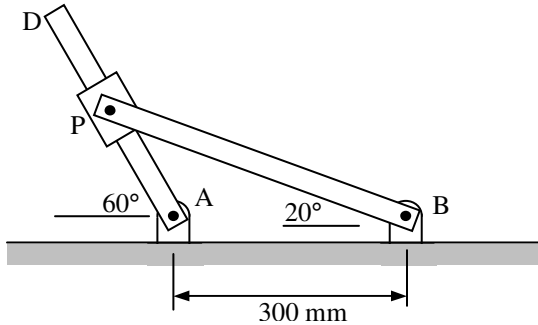

Problem 4.32 (from *Vector Mechanics for Engineers: Dynamics* by Beer and Johnston)

The hydraulic cylinder CD is welded to an arm which rotates clockwise about A at a constant rate $\omega = 2.4$ rad/s. Knowing that in the position shown BE is being moved to the right at a constant rate of 15 in/s with respect to the cylinder, determine, a) the velocity of point B, b) the acceleration of point B.

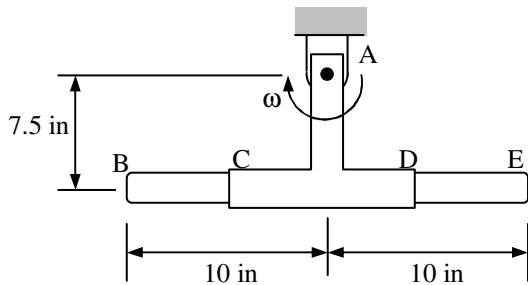

Problem 4.33 (from *Vector Mechanics for Engineers: Dynamics* by Beer and Johnston)

At the instant shown bar BC has a constant angular velocity of 2 rad/s counterclockwise. Determine the angular acceleration of the plate.

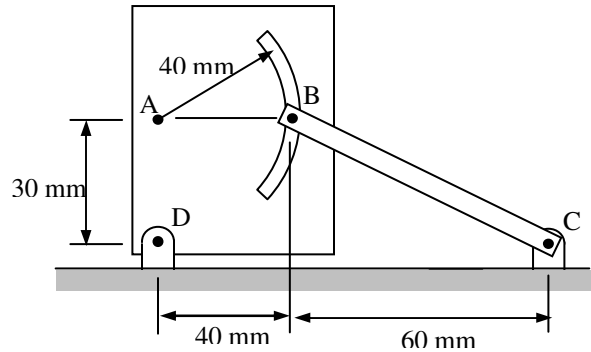

Problem 4.34

Two rotating rods are connected by slider block P. Neglect friction between the slider block and bar AD. The rod attached at A rotates with a constant angular velocity of 10 rad/s clockwise. Determine:

- the angular acceleration of the rod attached at B,
- the relative acceleration of slider block P with respect to the rod on which it slides.
- If bar AB has a mass of 5 kg the mass of the slider is negligible, determine the reactions at point B.

Hint: Use the velocities you found in problem 28.1.

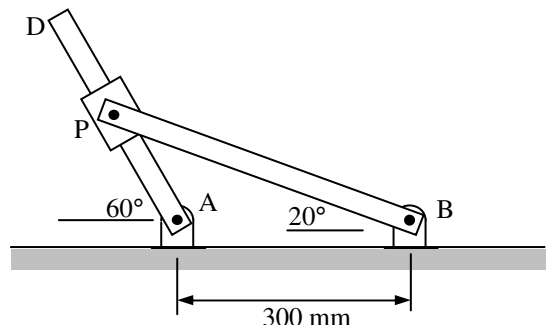

Problem 4.35

The uniform 60 lb log is supported by two cables and used as a battering ram. If the log is released from rest in the position shown, determine

- the tension in each cable immediately after release
- the corresponding angular acceleration of the cables.
- the tension in each cable when the cables are vertical.

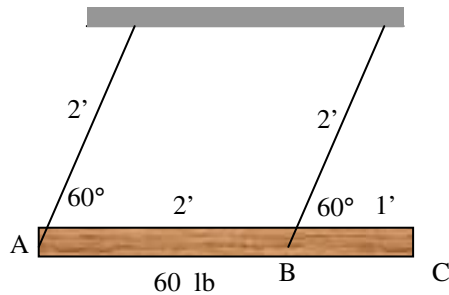

Problem 4.36

Two blocks A and C are welded together and they rest on top of wedge B. Incline B has a weight, W_B , block A has a weight, W_A and block C has a weight, W_C . The parameters, w , h_1 , h_2 , and θ are all known.

- Assuming the friction between A and B is large enough to prevent sliding, determine the equations necessary to find the force, F , so that block A does not tip in a counterclockwise direction.
- Using $w = 0.8''$, $h_1 = 0.8''$, $h_2 = 0.4''$, $W_A = 1 \text{ lbf}$, $W_B = 2 \text{ lbf}$, $W_C = 0.4 \text{ lbf}$, and $\theta = 20^\circ$, determine a numerical value for F .
- Assuming $F = 0$ and the friction between block A and B is magically reduced to zero and block A does not tip, determine the velocity of block A and block B after A has moved a distance $d = 3''$ down the incline.

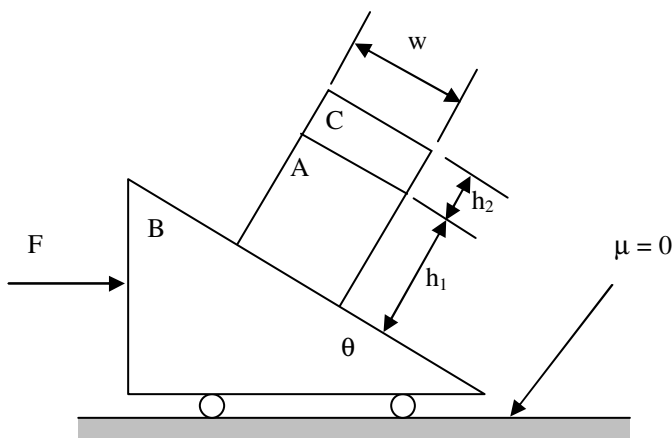

Problem 4.37

A gear reduction system consists of three gears A, B, and C. Gear A starts from rest at time $t = 0$ and rotates clockwise with constant angular acceleration. Knowing that the angular velocity of gear A is 600 rpm at time $t = 2 \text{ s}$, determine (a) the angular accelerations of gears B and C, (b) the accelerations of the points on gears B and C which are in contact when $t = 0.5 \text{ s}$.

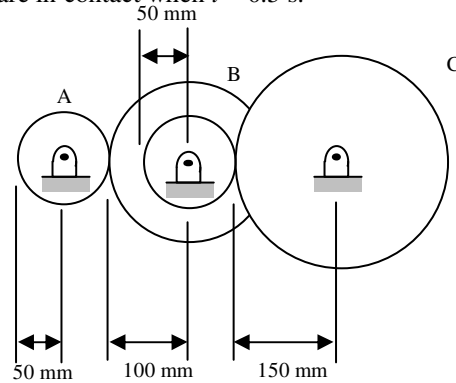

Problem 4.38

A bar is pinned at point O and a moveable mass is attached to it as shown. The system is released from rest in the horizontal position and a sensor is attached to the top of the bar to measure its angular position. The system has the following nominal parameter values:

- m_p = pendulum mass = 68.5 g
- m_w = moveable weight = 88 g
- L_p = pendulum length = 43.2 cm
- d_s = Sensor diameter = 2.5 cm
- d_w = moveable weight diameter = 5 cm

Assuming the pendulum rod is mounted flush with the top of the sensor, and moveable weight is not moved lower than flush with bottom edge of pendulum rod, we would observe that

- L_{cg_min} = minimum location for moveable mass = $(d_s + d_w)/2$
- L_{cg_max} = maximum location for moveable mass = $L_p - (d_s + d_w)/2$
- $L_{cg_pendulum}$ = location of the pendulum center of gravity = $(L_p - d_s)/2$

Determine:

- Plot the angular velocity of the pendulum when it is vertical as a function of the location of the moveable mass.
- Determine the location, L_{cg} , that will maximize the angular velocity when the bar is vertical.

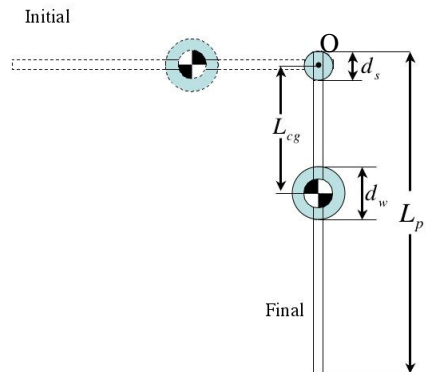

Problem 4.39

A 45-g bullet is fired with a velocity of 400 m/s into a 9-kg panel of side $b = 0.2$ m as shown. Knowing that the bullet strikes the plate at a height $h = 190$ mm and that the panel is initially at rest, determine

- the velocity of the center of the panel immediately after the bullet becomes imbedded,
- the impulsive reaction at A, assuming that the bullet becomes imbedded in 2 ms.
- the reaction at A after the plate has swung through an angle of 90 degrees

Note: For part c) neglect the mass of the bullet since you do not know exactly where it will become lodged in the plate.

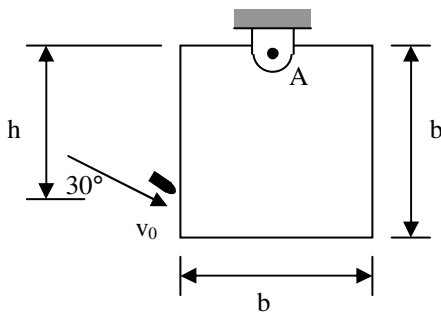

Problem 4.40

A slender 4 kg rod can rotate in a vertical plane about a pivot at B. A spring having a constant of $k = 400$ N/m and unstretched length of $l = 150$ mm is attached to the rod as shown. The rod is released from rest in the position shown. Determine the angular velocity of the rod after it rotates through 90°.

Determine

- the angular velocity of the rod after it has rotated through 90°
- the reactions at point B after the rod has rotated through 90°

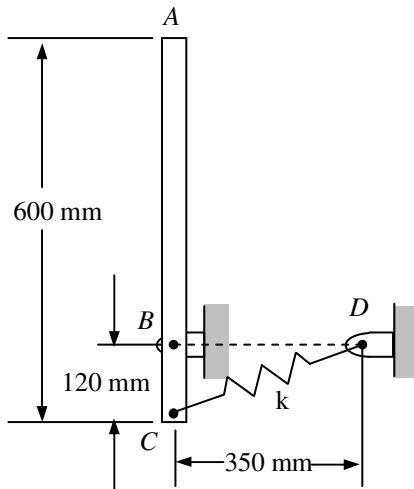

Problem 4.41

The gear has a mass of 2 kg and a radius of gyration of 0.19 m. The connecting link (slender rod) and the slider block at B have a mass of 4 kg and 1 kg, respectively. If the gear is released from rest in the position where $\theta = 30^\circ$, determine the angular velocity of the gear when $\theta = 0^\circ$. Only a portion of the two tracks are shown.

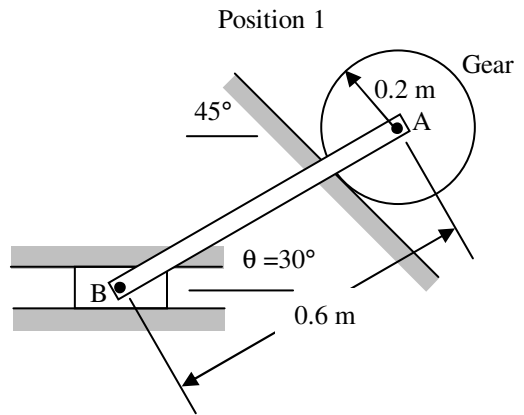

Problem 4.42

A homogeneous cylindrical disk of mass m rolls without slipping on the horizontal surface with angular velocity ω . If it does not slip or leave the slanted surface when it comes into contact with it, determine the maximum elevation, h_{final} that the disk will achieve.

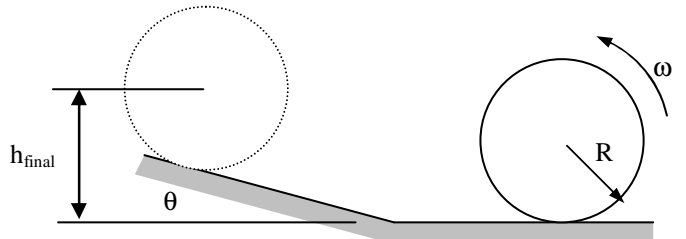

Problem 4.43

Puffy the cat is peacefully sitting on a chair as shown when her arch enemy Fido pulls on the rope as shown. Puffy weighs 8 lbs and the chair weighs 14 lbs. The centers of gravity of the cat, G_{cat} , and of the chair, G_{chair} are shown. Assume the wheels allow the chair to roll freely (that is no friction).

- Determine the magnitude of the force in the rope so that the chair and cat are about to tip over (much to Fido's delight) assuming the cat does not move relative to the chair.
- Determine the friction force between the cat and the chair assuming the coefficients of friction are $\mu_s = 0.5$ and $\mu_k = 0.3$

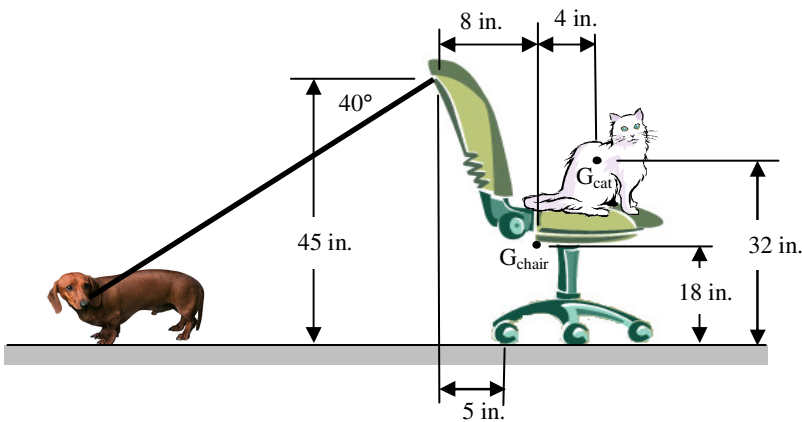

Problem 4.44

A spring-loaded slider of mass 1.5 kg is positioned in the frictionless U-slot as shown in the figure. It is released from rest at point A, with the spring horizontal. The spring can be assumed to have an initial stretch of 0.1 m, and the spring constant is 50 N/m. (a) Find the speed of the slider at position B. (b) Calculate the force exerted by the slot on the slider at this position.

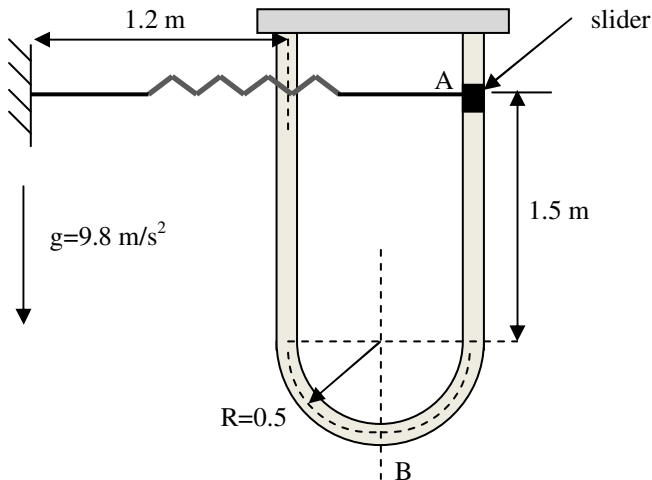

Problem 4.45

A slider (mass = 0.60 kg) is made to slide in a smooth slot through the application of a force, P , that is tangential to the slot. The slot is described by a spiral curve $r = 1.5 \theta$ meters. The angular rate is a constant, $\dot{\theta} = -4.0$ rad/second, and $\theta = 90^\circ$. In this configuration, calculate the magnitude of P required to produce this motion and determine the normal force being exerted by the side of the slot on the slider.

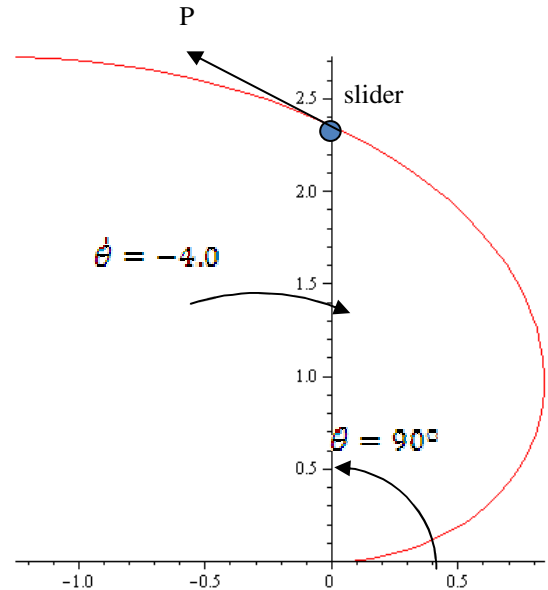

Problem 4.46

Two slender bars of length, L , are welded together with an angle of 120° between the bars as shown. The welded object is then pinned at B. Each individual bar has a mass m and a mass moment of inertia of I_G . A small glob of putty, D, of mass m_D strikes the end C of member ABC with a velocity v_0 and the putty sticks to the bar.

- Determine the equations necessary to find:
 - angular velocity of ABC immediately after impact
 - the reactions at B immediately after the impact

You may assume the glob is a point mass.

- Assuming that $v_0 = 1.5$ m/s, $m = 0.7$ kg, $L = 0.4$ m, and $m_D = 0.5$ kg determine numerical answers to part a).

