

Executive Summary

The deicing process that airports utilize to remove snow and ice from their aircraft has an adverse impact on the environment. Due to environmental concerns, the Environmental Protection Agency (EPA) has announced that they will be changing the biochemical oxygen demand permit levels of airport deicers. In response to these more strict regulations to be announced later this year, the Federal Aviation Administration (FAA) has hosted a competition to make the deicing process at airports more environmentally friendly. Our student team at Rose-Hulman Institute of Technology has joined this competition.

Our team proposes that deicing pods be created at airports, which shall be the only locations where deicing is allowed to occur. These pods will be centrally located, in order to decrease aircraft holdover times. Planes can enter the pods from adjoining taxiways and get sprayed by deicing vehicles, then continue to other taxiways en-route to a runway. These deicing pods will drain to a pipe system will need to be constructed to carry fluids from the deicing pods to a storage basin. Fluid being held in this storage basin can be used later for recycling purposes.

Along with handling the deicing fluid, our team also proposes that airports utilize a number of different best management practices. For example, it is proposed that they use enclosed-basket deicing vehicles equipped with forced-air systems so that operators are protected and can get closer to the airplanes to perform the deicing process better. Furthermore, preventative anti-icing should be used. This involves spraying planes with anti-icing fluid before a large weather event is supposed to occur, thus making most of the deicing process nearly obsolete.

Problem Statement and Background

In the of making snow and ice removal more environmentally friendly for the airport environmental interactions technical design challenge, our team used our strong academic background as well as work experience to assess all the options we have come across. Our team was aided by the help of the Civil Engineering staff at Rose-Hulman. Our professors, namely Dr. Michael Robinson, guided us in the right direction on this project to help us produce a quality recommendation to improve the means in which airports perform their anti- and deicing as well as improved containment and cleanup of anti- and deicing products.

Our team reviewed the *Preliminary Data Summary: Airport Deicing Operations EPA 821-R-00-016* as well as consulted with Todd Cavender, CECM the Environmental Manager for BAA Indianapolis of the Indianapolis International Airport (EPA, 2000). The *Preliminary Data Summary* gave our team information of what technologies and procedures were currently in use across America and Mr. Cavender was able to give us more insight to the problem specific to the Indianapolis International Airport.

The problem of concern is that in the deicing season at airports nationwide, airports use millions of gallons of anti- and deicing fluid with little regulation. These chemicals, namely glycol based fluids, can be toxic to the wildlife in the receiving waters they are discharged to, as well as have a large biochemical oxygen demand on these waters. Our project was tied into our senior design project for class as a more specific solution for the Indianapolis International Airport and a more general solution for this FAA competition that can be implemented nation wide.

In the following report, our group discusses the options we found. There are solutions that are as easy as new methods of applying the anti- and deicing fluids which reduce the total amount of these fluids that need to be used to the way they should be handled once used to further reduce their impact on the environment.

The biggest challenge to overcome was to find practical solution that can be implemented nationwide since our nation's airports are located in a multitude of climates, some of which require heavy anti- and deicing during the deicing season in the northern states and less anti- and deicing in the southern states. Another challenge was to find a solution that would contribute minimal cost, as there are some procedures and technologies available that can be very costly to implement and which could require construction in such a way that would hinder flight scheduling times during construction. If flight schedules would be affected in a negative way, this would create a cost to both the airport as well as the airlines since they could not get as many flights out in the same amount of time as they currently operate at. Flight scheduling times would not want to be interrupted during construction and any solution that would be recommended would need to not interfere with flight schedules once in operation.

Our team feels we had a good handle on all these challenges and was able to overcome them with success. We feel that the recommendations made in the following report meet all the requirements of this competition and would be not only beneficial for airports to implement as it would lower cost on anti- and deicing procedures in the long run but would also be less detrimental to the environment.

Summary of Literature Review

Our team first had to learn about the anti- and deicing process at airports as none of our classes have prepared us for this competition and our professors were also lacking on knowledge of the process. This included our reading of the *Data Summary: Airport Deicing Operations EPA 821-R-00-016*. This document was very helpful in our decision process and provided us with a collected source of data from airports nationwide. We also read through the NPDES report for the Indianapolis International Airport to familiarize ourselves with one and to also better understand the regulations as they are now set.

Mr. Cavender was also able to provide us with much help when we had questions about the process or airports. Mr. Cavender provided us with several of the past few years of annual deicing reports from the Indianapolis International Airport. These documents helped our team learn a little more of the size of the Indianapolis International Airport's aircraft anti- and deicing operations and in what ways our design could help. A list of references can be found in Appendix F.

Team's Problem Solving Approach to the Design Challenge

Upon assignment of our senior design project, we first collaborated as a team on ideas relating to the subject of snow and ice removal for anti- and deicing an aircraft. Generally, this was difficult to come by as neither our professors or our team had any previous knowledge of the subject. Throughout our research, we kept in mind the purpose of the project, which was to emphasize coming up with a design that is environmentally friendly. To begin, everyone in our group conducted preliminary research and found out as much as possible relating to the process, airports, chemicals, uses and anything else involved with deicing an aircraft. As information was obtained, we decided to come up with various suggestions and design options that were relevant.

At this point, after meeting with our client contact at the Indianapolis International Airport, we created a decision matrix that fit his needs. We ran all of our design options through the decision matrix and came up with the best option. This turned out to be the redesign of the deicing pods and the use of best management practices (BMPs). This was approved by our client contact and our final design represented both options equally. In our research, it was discovered that these BMPs could be recommended as a solution to airports nationwide. While our design of the deicing pods was specific to the Indianapolis International Airport, we feel the general idea of our design is a practical solution for airports nationwide as it allows for better treatment of the waste anti- and deicing fluids at a minimal cost.

Description of the Technical Aspects

Our team proposes that deicing pods be added to airports, which shall be the only locations where aircraft deicing operations are permitted. A sample pod can be seen in Figure 1.

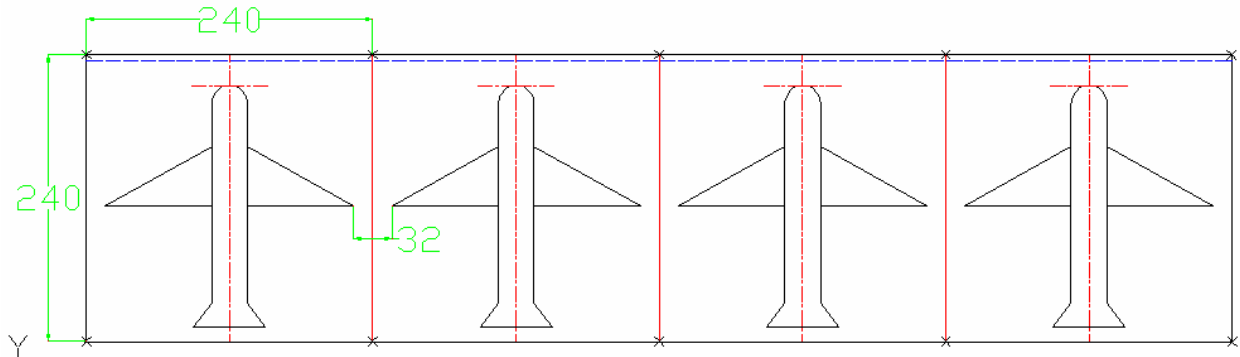

Figure 1

A pod can have a varying number of aircraft parking spaces, depending on the size of the airport, and the amount of air traffic it receives. A parking area of 240'x240' will accommodate aircraft sizes up to the Boeing 747. While on the pad, aircraft will be surrounded and sprayed with fluid by up to four deicing vehicles. These pods should be connected to adjoining taxi-ways, enabling aircraft to pull in and out of them, en-route to a runway. An example of pods being placed at an airport is visible in Figure 2 on the next page, with three deicing pods being strategically placed at the Indianapolis International Airport. Deicing pods will have a 0.05% slope, aligned with existing topography, so all the runoff deicing fluids can be collected into a gutter system. Furthermore, there should be flood lights located at the corners of each pod, so that deicing can be accomplished all day without a loss of visibility.



Figure 2

Runoff fluid from the deicing pods should be separated, so that fluids with a high concentration of waste deicing glycols can be contained and stored for possible later use. Pipes will need to be designed to carry the waste deicing fluids from the pods, to the storage basin. Time of Concentration will first be calculated for each pod, utilizing the surface area and slope:

$$T_c = \frac{C_k * L^{0.77}}{S^{0.385}}$$

Peak discharge values can then be calculated via the Rational Equation: $Q = CiA$.

Finally, pipes carrying these discharged fluids can be sized using Manning's Equations:

$$Q = \frac{1.49}{n} * A * Rh^{\frac{2}{3}} * S_0^{\frac{1}{2}}$$

A hydraulic study of the airport would need to be conducted to determine the size of the pond needed to hold all the runoff. Our design for the Indianapolis International Airport consists of a two million gallon tank.

Description of Interactions with Airport Operators and Industry Experts

Our team has had several contacts with airport operators and industry experts. Our primary contact was Todd Cavender, who is the environmental manager at the Indianapolis International Airport. We also communicated via phone with many other experts across the United States, and in Canada. Finally, we utilized resources on the internet.

Our primary contact was Todd Cavender. He gave us several tours at the Indianapolis International Airport, showing us the current deicing operations, as well as the current storm water operations. He also provided us with a steady stream of information, as well introducing us to key contacts.

Our phone conversations were conducted with many different people across the United States. We also had some limited communication with Arlene Beisswenger, a laboratory manager at the University of Quebec at Chicoutimi. Arlene was able to provide us with detailed fluid characteristic. We also communicated with John Lengel, who is involved with the creation of the new standards that the EPA is working on releasing later this year. We communicated with officers in the Air Force and Army, dealing with their current research into deicing procedures that are less damaging to the environment.

Finally, we utilized the internet for further sources of information. We were able to find data on a wide variety of topics, from average snow fall in Indianapolis to various methods and standards of deicing, across America.

Description of the Projected Impacts of the Team's Design and Findings

Our team's suggestion is the implementation of newly designed deicing pods, collection systems, pipe networks, storage pond and best management. Our team's design allows for no polluted runoff due to anti- and deicing operations of aircraft since all runoff during those operations will be sent directly to storage pond. This design not only meets FAA goals of limiting and controlling deicing fluid of aircraft, it far surpasses it. In our design, aircraft anti- and deicing procedures take place in very limited areas, called deicing pods. These deicing pods must have their own collection system to collect the runoff with a high concentration of anti- and deicing fluids. This runoff is then piped to a storage tank where it can be held until an outside company can come to pump out the fluid so it can be recycled. These outside companies often pay to acquire this fluid and would in turn generate small revenue for the airport. The use of anti- and deicing fluids on the airfield was ignored for our project as the amount of runoff from such large areas significantly reduces the concentration of the anti- and deicing fluids to the point where these fluids do not pose a problem.

Since our team is working directly with the Indianapolis International Airport, we have included the costs of such a design to be implemented at their airport. However, this can be used as a model for other airports trying to limit and control their deicing fluids. An important aspect of this design is that it will not hinder current operations at the Indianapolis International Airport.

Cost was an important design criterion for our team and was placed into consideration at the beginning of design. The significance of this criterion was a major decision factor

throughout the design process, as stressed by Mr. Cavender. Below are the cost numbers that our team has calculated for our design at the Indianapolis International Airport:

Table 1: Summary of Pipe Costs

<u>Item</u>	<u>Means Reference</u>	<u>Details</u>	<u>Quantity</u>	<u>Units</u>	<u>Bare Costs</u>	<u>Total Cost</u>
Piping network						\$4,369,805.48
Pipe	02510-810-2070	6' Diameter, Prestressed (PCCP), 150 PSI	3725.3	L.F.	\$223.54	\$832,752.63
Pipe	02510-810-2080	7' Diameter, Prestressed (PCCP), 150 PSI	3292	L.F.	\$272.63	\$897,506.19
Trenching	A12.3-110-1460	0 to 1 slope, 8' wide, 12' deep, 1-1/4 Cubic Yard Bucket	7017.3	L.F.	\$21.26	\$149,205.34
Roadway Removal	02220-875-2100	Concrete, 7" to 24" thick, reinforced	42448	C.F.	\$56.79	\$2,410,812.94
Pavement	02750-100-0500	Fixed form, 12' pass, 15" thick	2358	S.Y.	\$33.73	\$79,528.38

Table 2: Summary of Deicing Pod Costs

<u>Item</u>	<u>Means Reference</u>	<u>Details</u>	<u>Quantity</u>	<u>Units</u>	<u>Bare Costs</u>	<u>Total Cost</u>
Piping network						\$4,369,805.48
Pipe	02510-810-2070	6' Diameter, Prestressed (PCCP), 150 PSI	3725.3	L.F.	\$223.54	\$832,752.63
Pipe	02510-810-2080	7' Diameter, Prestressed (PCCP), 150 PSI	3292	L.F.	\$272.63	\$897,506.19
Trenching	A12.3-110-1460	0 to 1 slope, 8' wide, 12' deep, 1-1/4 Cubic Yard Bucket	7017.3	L.F.	\$21.26	\$149,205.34
Roadway Removal	02220-875-2100	Concrete, 7" to 24" thick, reinforced	42448	C.F.	\$56.79	\$2,410,812.94
Pavement	02750-100-0500	Fixed form, 12' pass, 15" thick	2358	S.Y.	\$33.73	\$79,528.38

Table 3: Summary of Pond Costs

<u>Item</u>	<u>Means Reference</u>	<u>Details</u>	<u>Quantity</u>	<u>Units</u>	<u>Bare Costs</u>	<u>Total Cost</u>
Pond						\$184,900.00
Excavation	02315-400-0300	backhoe, hydraulic, crawler mtd, 3 C.Y. cap = 160 C.Y. /hr	10,000	C.Y	\$2.00	\$20,000.00
Hauling	02320-200-0540	12 C.Y. dump truck, 5 mi round trip, 1 load/hr	10,000	C.Y	\$8.09	\$80,900.00
lining	02660-400-0300	Membrane Lining, HDPE, 120 mil thick	50,000	SF	\$1.68	\$84,000.00

Table 4: Summary of Total Costs

Total Cost of Piping	\$4,370,000.00
Total Cost of Deicing Pods	\$3,245,000.00
Total Cost of Pond	\$185,000.00
Total Cost of Project	\$7,800,000.00

Included in our team's design was the use of best management practices. These practices include forced air systems, enclosed-basket deicing trucks and preventative anti-icing. These three best management practices (BMP) are not the only ones available, but it is our teams opinion that they are the easiest to implement and have the most significant reductions to the use of anti- and deicing fluids.

Deicing vehicles are commonly used at airports to surround airplanes and spray them with deicing fluid. By making the baskets on these vehicles enclosed, the overall use of deicing fluid can be reduced. An example of a deicing vehicle with an open basket is shown in Figure 3, while an enclosed-basket deicing vehicle can be seen in Figure 4.



Figure 3: Open Basket



Figure 4: Enclosed Basket

As is visible in Figure 4, the enclosed-basket allows the operator to be free from the elements. While deicing, the operator does not have to worry about fluid rebounding off the aircraft back at them, which allows them to get closer to the aircraft and more efficiently deice. Furthermore, since deicing usually occurs on cold days, the operator can perform their duties in a confined heated area, so the overall performance will improve. Some airlines have reported a total deicing fluid reduction of 30% by making use of enclosed-basket deicing vehicles (EPA, 2000).

Another BMP that is important to consider involves making use of forced air systems. Forced air deicing includes the combination of using high-pressure jets to blast off snow and ice. These devices can replace the normal nozzles that are mounted on deicing vehicles. An example of a forced air system is also shown in Figure 4 as the nozzle at the front of the basket is equipped for forced air. Making use of these systems has reported in a reduction of the volume of deicing fluid required by at least 30%.

Finally, our team proposes the use of preventative anti-icing. This is a very effective BMP, which involves spraying aircraft with anti-icing fluid before a storm event is scheduled to occur. Because the anti-icing fluid prevents ice from collecting on aircraft, less deicing fluid has to be used later on. Using preventative anti-icing it is possible to decrease fluid use by around 75%.

Best Management Practices are a great way to reduce the amount of deicing fluid used at any airport. It is difficult to tell how much deicing fluid can be saved by using a combination of these three BMPs, since preventative anti-icing does not directly correlate with forced air systems and enclosed-basket deicing trucks. However, our team is confident that at a minimum, total deicing fluid used per year can be cut in half by making use of these BMPs.

FAA University Design Competition

Appendix A – Contact Information

Name	Permanent Address	Email	Phone Number
Robinson, Dr. Michael	5500 Wabash Av. CM63 Terre Haute, IN 47803	robinson@rose-hulman.edu	812-877-8286
Armstrong, Christopher	2810 46th St. Des Moines, IA 50310	rhitopher@yahoo.com	515-720-4437
Johanning, Mark	801 S. 400 W. Jasper, IN 47546	johannmj@rose-hulman.edu	812-639-1279
Kenny, William	21902 A. St. Eagle, NE 68347	kennywr@rose-hulman.edu	402-250-6323
McIlwaine, David	11542 N. Via de la Verbenita Tucson, AZ 85737	dmac2215@yahoo.com	317-402-9612
Wilson, Robbie	27 White Oak Dr. Batesville, IN 47006	wilsonrw@rose-hulman.edu	812-212-1014

FAA University Design Competition

Appendix B - Description of Rose-Hulman

For the eighth consecutive year, Rose-Hulman Institute of Technology is ranked number one by engineering educators as the nation's best college or university that offers the bachelor's or master's degree as its highest degree in engineering, according to rankings that will be included in the 2007 edition of "America's Best Colleges" guidebook published by U.S. News & World Report.

Rose-Hulman has maintained this ranking for the past eight years by following our mission and vision. Rose-Hulman's mission is to provide students with the world's best undergraduate education in engineering, mathematics, and science in an environment of individual attention and support. Rose-Hulman's Vision is to be the best undergraduate engineering, mathematics and science institution in the world.

Rose-Hulman has kept in line with this mission and vision by putting the students first through maintaining small size, small classes, and individual attention, and providing active help and a general sense of caring support. Rose-Hulman also fosters growth of all its community members by stimulating creativity, curiosity, and intellectual excitement and preparing students for leadership roles. Rose-Hulman provides an opportunity to develop the skills required of the technical professional by emphasizing a systematic, rigorous grounding in fundamentals. Rose-Hulman seeks continuous improvement in all its programs by striving to enhance our role as an innovator in technical education. Rose-Hulman contributes to society and fosters citizenship and service in its members through developing an understanding of the impact of science and technology on society and playing an active role in bettering the community.

FAA University Design Competition

Appendix C - Description of BAA Indianapolis

Although Design Solutions Limited communicated with many different people and corporations, our primary contact was Todd Cavender the environmental manager of BAA Indianapolis L.L.C (BAA). BAA manages the Indianapolis International Airport (IIA). BAA Indianapolis L.L.C. has managed IIA since October 1, 1995. BAA Indianapolis, L.L.C. is a subsidiary of the British Airport Authority, the company that manages several United Kingdom airports.

Mr. Cavender is in control of many things, but the most important aspect of his responsibility is his control of the storm water treatment system. Currently, IIA has two primary detention ponds for storm water. Mr. Cavender gave us a tour of their storm water system and showed us its sophisticated control system. It is this control system that we hope to tie in the override for the deicing system.

FAA University Design Competition

Appendix D - Design Proposal Submission Form

Note: This form should be included as Appendix D in the submitted PDF of the design package. The original with signatures must be sent along with the required print copy of the proposal.

University: Rose-Hulman Institute of Technology

List other partnering universities if appropriate _____

Proposal Developed by: Individual Student Student Team

If Individual Student

Name _____

Permanent Mailing Address _____

Permanent Phone Number _____ Email _____

If Student Team:

Student Team Lead: Christopher Armstrong

Permanent Mailing Address: 2810 46th St
Des Moines, IA 50310

Permanent Phone Number: (515) 720-4437 Email: rhitopher@yahoo.com

Competition Design Challenge Addressed:

Making Airport Deicing More Environmentally Friendly

I certify that I served as the Faculty Advisor for the work presented in this Design Proposal and that the work was done by the student participant(s).

Signed _____ Date _____

Name: Dr. Michael Robinson

University/College: Rose-Hulman Institute of Technology

Department(s): Civil Engineering

Street Address 5500 Wabash Ave CM63

City: Terre Haute

State: IN

Zip Code: 47803

Telephone: (812) 877-8286

Fax: (812) 877-8440

FAA University Design Competition

Appendix D - Design Proposal Submission Form

Note: This form should be included as Appendix D in the submitted PDF of the design package. The original with signatures must be sent along with the required print copy of the proposal.

University: Rose-Hulman Institute of Technology

List other partnering universities if appropriate _____

Proposal Developed by: Individual Student Student Team

If Individual Student

Name _____

Permanent Mailing Address _____

Permanent Phone Number _____ Email _____

If Student Team:

Student Team Lead: Christopher Armstrong

Permanent Mailing Address: 2810 46th St
Des Moines, IA 50310

Permanent Phone Number: (515) 720-4437 Email: rhitopher@yahoo.com

Competition Design Challenge Addressed:

Making Airport Deicing More Environmentally Friendly

I certify that I served as the Faculty Advisor for the work presented in this Design Proposal and that the work was done by the student participant(s).

Signed _____ Date _____

Name: Dr. Robert Houghtalen
University/College: Rose-Hulman Institute of Technology
Department(s): Civil Engineering
Street Address 5500 Wabash Ave CM58
City: Terre Haute State: IN
Telephone: (812) 877-8449 Fax: (812) 877-8440

Zip Code: 47803

FAA University Design Competition

Appendix E – Evaluation of Education Experience

Student Evaluation:

Throughout the eight months our group has been working on this senior design project, we have learned many things. Among these obviously include engineering work, as well as real world difficult situations, such as trying to contact our client and having an extremely difficult time doing so. We had to plan on not having help when we expected it, and this was a common occurrence, so we figured out how to cope with these slight problems.

As far as the engineering, we used various methods from hydraulics and water resources. These corresponded with incorporating software such as AutoCAD and MathCAD to design our storage pond and deicing pods. Overall, as a group we felt that part of our best experience came from dealing with our client. We feel this could be an extremely worthwhile experience in terms of our future professional careers as engineers.

Faculty Evaluation:

The FAA Airport Design Competition for Universities provided a great educational experience for our students. A team of five senior civil engineering students worked with the Indianapolis International Airport to submit an entry in the Airport Environmental Interactions Challenges: Making snow and ice removal more environmentally friendly. The Civil Engineering Department seeks to provide an educational experience that provides students with an awareness of the role of engineering in solving the complex technological and social problems of the environment and social/political world.

The project provided the students the challenge of quickly researching and understanding a new field of knowledge. The students quickly recognized the need to become knowledgeable about the process. With little knowledge about how airports operate and perform snow and ice removal, they researched the literature and spoke with representatives from the Indianapolis International Airport to better understand the process. They recognized lifelong learning is essential for an engineer to solve complex problems in a changing world. Engineers of tomorrow need to be able to learn on their own because of the rapid technological changes.

The project provided the students the challenge of dealing with an open-ended design problem that had no clear, easily identifiable solution. The students needed to synthesize a large amount of data, establish appropriate criteria for determining an optimal solution, generate several design options that provided a solution to the problem, and then select the optimum solution based on the previously selected criteria. The project provided the exact experience in an educational setting that the students will encounter as practicing engineers.

The project provided the students the challenge of interacting with the “real world” to solve a problem. The students had to interact with personnel from the Indianapolis International Airport and other agencies to obtain a significant amount of the data they needed for their design. Information was not provided to the students in a textbook manner – all the necessary data in a clear, concise format. Deadlines, slow responses to information requests (at least in the view of the students), and incomplete or inappropriate data were some of the challenges encountered by the students. This required the students to learn the social engineering aspects of having to work with and rely on several different organizations to develop an effective engineering solution. Solutions to complex engineering problems are increasingly interdisciplinary and often require expertise outside of engineering. This project made the students aware of this reality.

In summary, the educational experience provided by our students participating in the FAA Airport Design Competition was excellent. The students learned the value and necessity of lifelong learning, the challenges of solving open ended problems with no obvious optimal solution, and the importance and difficulties of working with other organizations to develop the optimum solution to that open ended problem.

FAA University Design Competition

Appendix F - References

- Environmental Protection Agency. (2000). *Preliminary Data Summary: Airport Deicing Operations, EPA –821-R-00-016.*
- Wessler and Associates. (2000) *Indianapolis International Airport 1999-2000 Deicing Season Annual Report.* June 14, 2000.
- Wessler and Associates. (2001) *Indianapolis International Airport 2000-2001 Deicing Season Annual Report.* August 3, 2001.
- Wessler and Associates. (2002) *Indianapolis International Airport 2001-2002 Deicing Season Annual Report.* September 16, 2002.
- Wessler and Associates. (2003) *Indianapolis International Airport 2002-2003 Deicing Season Annual Report.* July 15, 2003.
- Wessler and Associates. (2004) *Indianapolis International Airport 2003-2004 Deicing Season Annual Report.* August 31, 2004.
- Wessler and Associates. (2006) *Indianapolis International Airport 2005-2006 Deicing Season Annual Report.* 2006.